

Shaker Cylinders

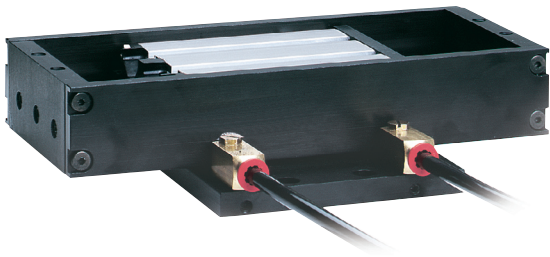

Shaker Series Features and Benefits

Shaker systems are pneumatically driven Feeder/Beltless Conveyor systems. These systems are ideal for the stamping industry or other parts transfer and scrap removal applications.

Compared to traditional conveyor systems, this "shaker" will save time and money!



**MODEL SHOWN:
SHK-25 WITH INTEGRAL VALVE**



**MODEL SHOWN:
SHK-12-R WITH REMOTE VALVE**

Use of Common Components

The use of standard Turn-Act cylinder components drastically reduces maintenance costs and down time.

A Model to Fit Any Application

Five base models to fit your specific die openings with all the power for a single tray or multiple tray applications.

Simplicity of Design

Fewer moving parts than competitive units means higher reliability and less maintenance.

Bolt It Up & It's Ready to Go

Simply mount to the die base and connect air.
No electrical connections needed.

All-Air Shifting

Eliminating mechanical shifting enhances dependability and extends cycle life.

Anodized Housing

Combines high strength mounting surface while protecting internal components.

Multi-Directional Speed Control

Independent controls allow adjustability in both forward and reverse directions.

Enersorb™ Piston

A patented piston design that provides smooth operation with non-lube service, high noise and energy absorption and an extended cycle life.

Specifications

- 5 base models
- 3/4 to 2 1/2 inch bores
- Tray loads to 50 pounds
- Maximum loads to 140 pounds
- Uses a shaking tray system that conveys finished parts, scrap or chips
- Lower cost than motorized conveyors
- Eliminate costly maintenance and replacement of belts and rollers
- Control valve can be integral or remote mounted

Air Pressure: 40-120 psi

Temperature: 32° - 180° F

Sound Level: 70 db

Recommended Speed: 60 cycles per minute

How to Order

Model #	Load Capacity	Max. Tray Weight	Shipping Weight	Stroke
SHK-12	50 LBS	15 LBS	17 LBS	4 IN
SHK-25	140 LBS	50 LBS	34 LBS	3 IN
SHK-07R	20 LBS	6 LBS	5 LBS	2 IN
SHK-12R	50 LBS	15 LBS	10 LBS	2 IN
SHK-25R	140 LBS	50 LBS	28 LBS	2 IN

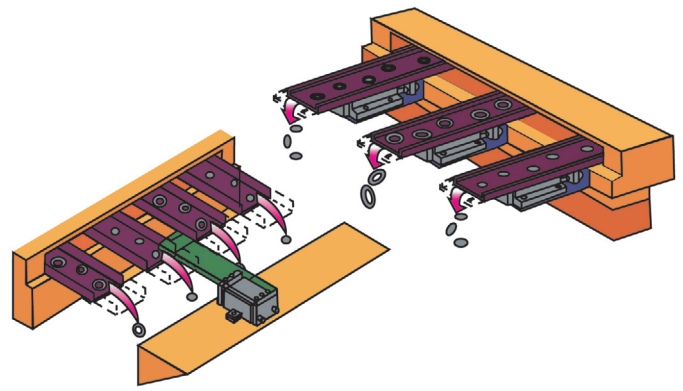

Engineering Data

Standard Shaker Integral Mount Valve

Dimensional Specifications		
	SHK-12	SHK-25
A	12.93	12.68
B	4.69	5.63
C	5.00	5.00
D	5.80	8.66
E	8.68	11.66
F	7.68	10.41
G	4.00	3.75
H	.41	.53
J	1.44	1.50
K	.94	1.03
L	3.06	3.10
M	.50	.63

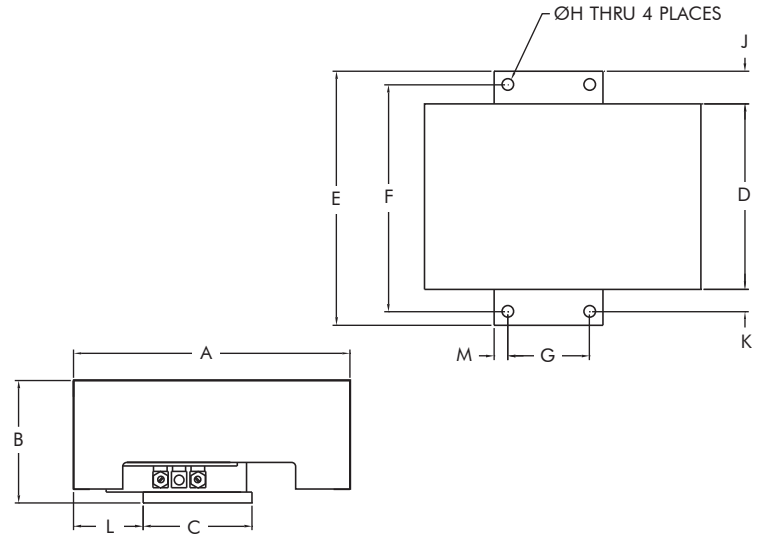

Low-Profile Shaker Remote Mount Valve

Dimensional Specifications			
	SHK-07R	SHK-12R	SHK-25R
A	5.50	7.00	9.00
B	4.88	6.25	8.00
C	3.50	5.00	6.88
D	.31	.38	.50
E	1.25	1.50	1.50
F	1.56	1.75	2.09
G	1.00	1.00	1.06
H	.41	.84	1.44
J	2.75	3.13	3.44
K	.69	.69	.63
L	#10-32	1/8 NPT	1/4 NPT
M	5/16	3/8	1/2
N	1.87	2.65	4.13
P	7.94	8.93	10.69
S	.38	.50	.75
T	7.56	*	9.94
U	.19	*	.38
V	1.03	*	2.00
W	1.23	*	2.44
X	#10-24	*	5/16-18

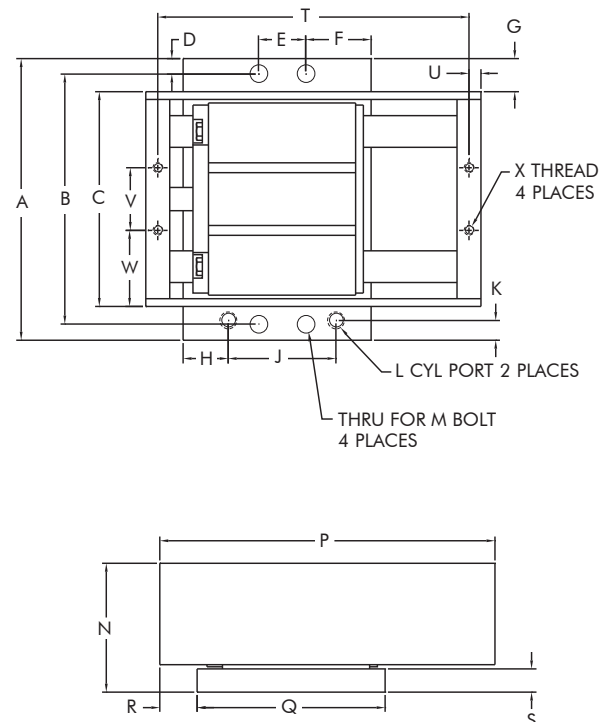

* 1-1/4 Bore has a top plate

Compact Automation Products, LLC
105 Commerce Way
Westminster, SC 29693
Tel: 864.647.9521
Fax: 864.647.9574
www.compactautomation.com