

Workholding Products

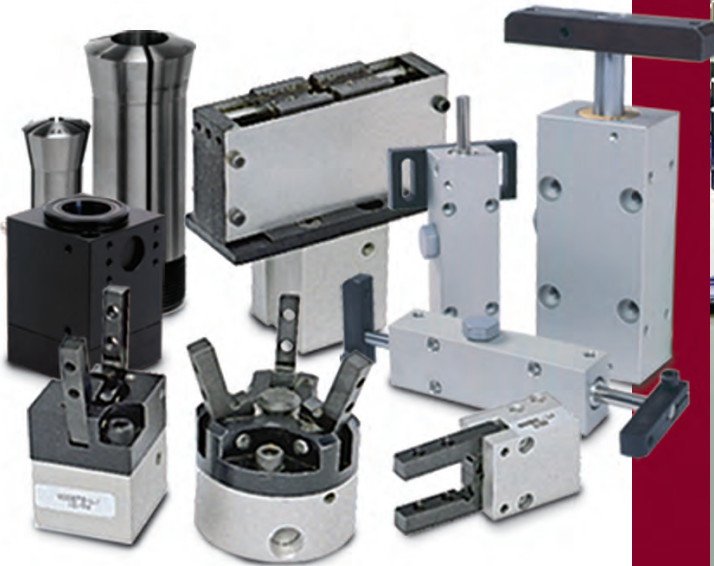

INTRODUCTION

Com-Pick and **Com-Pick II** grippers are designed for use in industrial applications such as robotics, pick-n-place, automated assembly, and manipulator/tooling. All units feature a self-contained, double-acting Compact Air Cylinder actuator. "Generic" grippers can be mounted to any manufacturer's robot, manipulator or actuator by way of an adaptor flange. Low unit weight, high output and compact size are features of all models. Special materials, tooling, and adaptor flanges are available upon request.

Compact Air stocks all units in component form. Seal options, jaw options, sensor options, etc., can be easily added at assembly for prompt delivery of all variations.

- UNIQUE PATENTED DESIGN •
- PREMIUM QUALITY •
- PROMPT DELIVERY •

SALES: 864-647-9521

TECHNICAL ASSISTANCE: 864-647-9568

FAX: 864-647-9574

All products manufactured under 1 or more of the following US patents: #4,167,134 ... #4,492,400 ... #4,566,727 ... #4,723,503 ... #4,723,806 ... #4,903,933 ... #4,924,758 ... #5,070,767 ... #5,113,746 ... #5,117,743 ... #5,135,329 ... #5,135,329 ... #5,245,911 ... #5,269,346 ... #5,290,981 ... #5,293,015 ... #5,333,536 ... #5,363,742 ... #5,351,603 ... #5,437,440 ... #5,456,161 ... #5,479,956 ... #5,522,302 ... #89 904 334 3-2301
Other US and Foreign patents pending. The specifications in this bulletin are believed to be accurate and reliable. However, it is the responsibility of the product user to determine the suitability of Compact Air's products for a specific application. While products found by Compact Air to be defective will be replaced, no liability is assumed beyond such replacement. Specifications subject to change without notice. Compact, Husky, Tuf-Coat, Snap-Cap, Clean Act, Comtronic, and World Class are all registered trademarks of Compact Air Products, Inc.

SECTION A ANGULAR MOTION GRIPPERS

Angular motion grippers represent the lowest cost design. The air cylinder is an integral component of the overall gripper length (Dimension B). The piston actuator pushes the cam, or yoke, forward, rocking/pivoting the jaws open. The pull stroke closes the jaws. A four-way valve circuit is required for control.

Both two and three jaw designs are offered. Round and square body styles are stocked.

Gripping force formulas, unit weights, and dimensions are included in this section.

SECTION B TRUE PARALLEL MOTION GRIPPERS

Parallel motion grippers represent a highly versatile and flexible design. The integral pneumatic cylinder pushes the jaws open. The jaws slide along two hardened guide rods providing rigid, long lasting true parallel motion. The pull stroke closes the jaws. A four-way valve circuit is required for control.

All units are of two jaw design.

Gripping forces, formulas, unit weights, and dimensions are included in this section.

SECTION C OPTIONS FOR ALL GRIPPERS

Options include:

Actuator Seals

Comtronic[®] limit sensors

Adjustable jaw travel

SECTION D APPLICATION IDEAS

A brief summary of applications. Photos and drawings show tooling ideas, specials, and unusual applications.

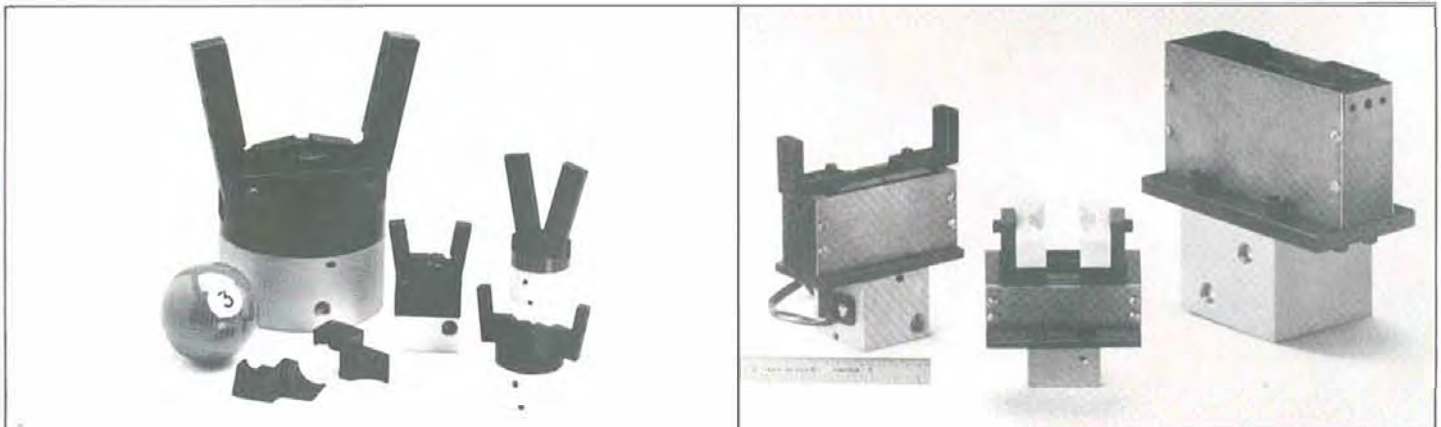

INTRODUCTION

Angular motion grippers represent the lowest cost design. The air cylinder is an integral component of the overall gripper length (Dimension B). The piston actuator pushes the cam, or yoke, forward, rocking/pivoting the jaws open. The pull stroke closes the jaws. A four-way valve circuit is required for control.

Both two and three jaw designs are offered. Round and square body styles are stocked.

Gripping force formulas, unit weights, and dimensions are included in this section.

ENGINEERING DATA

SELF CONTAINED ACTUATOR

All models feature Compact Air cylinder actuators as an integral, yet self-contained, component. Cylinders feature low profiles, low weight aluminum alloy bodies, and stainless steel piston rods. All units are pre-lubricated for life.

MATERIALS

Actuators are aluminum alloy with nylon rod bushings. Pivot head is anodized aluminum for low weight and high strength. Jaws, if purchased, are "1018" steel in soft form. Pivot joints are hardend and ground dowel pins.

ACTUATOR SEALS

As standard, actuators are packed with seals of Buna-N rubber. Temperature limits are from 0° F to 200° F (-18° C to 90° C). All actuators are pre-lubricated at the factory and do not require additional lubrication.
Seal options — Section C.

TOOLING

Com-Pick grippers are "generic" in standard form. You can make your own jaws/fingers (pivot drawing available on request), purchase our soft blank or pre-modified "L" jaws, add "V" blocks, pads, sensors, etc. Also, see Section D.

THEORETICAL GRIPPING FORCE FORMULAS — 2 Jaw Type (Pre-calculated reference — next page.)

072 = $\frac{F \times .437}{.187 + X}$	112 = $\frac{F \times .562}{.234 + X}$	162 = $\frac{F \times .750}{.281 + X}$
202 = $\frac{F \times .937}{.281 + X}$	252 = $\frac{F \times 1.187}{.469 + X}$	302 = $\frac{F \times 1.437}{.469 + X}$
402 = $\frac{F \times 1.875}{.578 + X}$	412 = $\frac{F \times 2.375}{.578 + X}$	502 = $\frac{F \times 2.375}{.578 + X}$
602 = $\frac{F \times 2.375}{.625 + X}$	802 = $\frac{F \times 2.75}{.812 + X}$	

"X" DISTANCE FROM GRIPPER FACE TO CENTERLINE OF GRIPPED PART

"F" CYLINDER OUTPUT (Piston Area × PSI)

	SERIES	070	110	160	200	250	300	400	500	600	800
	BORE	3/4	1-1/8	1-5/8	2	2-1/2	3	4	5	6	8
	ACTION										
PISTON AREA	PUSH OPEN	.4	1	2	3	5	7	12.5	19.6	28.3	50.3
	PULL CLOSE	.36	.8	1.7	2.7	4.5	6.5	12	19.2	27.5	49.5

THEORETICAL GRIPPING FORCE FORMULA — 3 Jaw Type

(Pre-calculated reference — next page)

Use formula's above, then multiply by % below

SERIES	073	113	163	253	303	403	503	603	803
%	72%	57%	79%	85%	70%	80%	78%	100%	100%

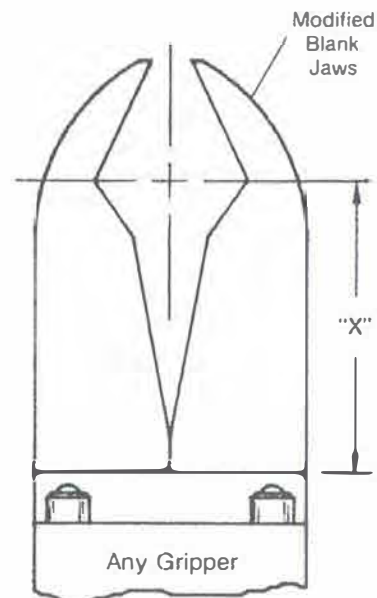

ENGINEERING DATA — Continued

PRESSURE RATINGS

PNEUMATIC	Clean, dry or lubricated — 5 PSI TO 200 PSI
HYDRAULIC	Consult Factory

2 Jaw Pre-Calculated Gripping Forces (In Pounds)

Nominal finger / jaw lengths (Material "1018" steel) Stock lengths listed on page 9												
Calculations below are theoretical, figured @ 100 PSI — Jaw length equals "X" variable in formula on previous page												
FINGER LENGTH		072	112	162	202	252	302	402	412	502	**602	**802
1"	OPEN	14	45	117	219	404	684	1485	1881	2949	4136	7633
	CLOSE	13	36	99	197	363	635	1425	1806	2889	4019	7512
2"	OPEN	8	25	65	123	240	407	909	1151	1805	2560	4919
	CLOSE	7	20	55	110	216	378	872	1105	1768	2488	4840
3"	OPEN	5	17	45	85	171	289	655	829	1301	1854	3628
	CLOSE	4	13	38	77	153	269	628	796	1274	1801	3570
4"	OPEN	*	*	35	65	132	225	511	648	1016	1453	2874
	CLOSE	*	*	29	59	119	209	491	622	996	1412	2828
5"	OPEN	*	*	*	53	108	183	420	532	834	1194	2379
	CLOSE	*	*	*	47	97	170	403	510	817	1161	2342

Gripping force is constant at any position of opening. If using 80 PSI, multiply above by 80%, 125 PSI multiply by 125%

* Long tooling not recommended on small grippers

**Not stock items

3 JAW PRE-CALCULATED GRIPPING FORCES

Multiply above forces by % given below

SERIES	073	113	163	253	303	403	503	603	803
%	72%	57%	79%	85%	70%	80%	78%	100%	100%

ESTIMATED UNIT WEIGHTS (w/o Jaws or Fingers) (lbs)

SERIES	07	11	16	20	25	30	40	41	50	60	80
2 Jaw	.28	.50	1.2	1.75	3.0	4.0	7.8	9.0	10.8	N/A	N/A
3 Jaw	.30	.49	1.0	—	2.5	3.7	7.2	—	10.0	N/A	N/A

DOUBLE ROD END ACTUATORS

All COM-PICK Grippers are available with a double rod end actuator. (Part Nos. "RDG," "SDG" and "BDG"). The double rod end actuator allows indication of jaw position via limit switch or proximity switch.

Example: As jaws open — the rod retracts. As the jaws close, the rod extends.

Rod travel is variable depending on unit size. Also see Piston Sensors in section C.

SECTION
A

**ANGULAR
MOTION
GRIPPERS**

**STYLE "SG" RECTANGULAR
BODY GRIPPER**
(End Mounted and Base Mounted)
ALL DIMENSIONS IN INCHES

**1/2" BORE
Snap-Cap
Design**

**2
JAW**

Design features three standard mounting patterns

Pressure Rating: 3 to 125 PSI
Clean, dry or lubricated air (air only)

Estimated Unit Weight:
SG052 = .08 lbs. / ASG052 = .11 lbs.

1/2" BORE 2-JAW ANGULAR GRIPPER

Gripper shown with 1" jaws - available with or without jaws.
See pages 9 and 10 for additional options.

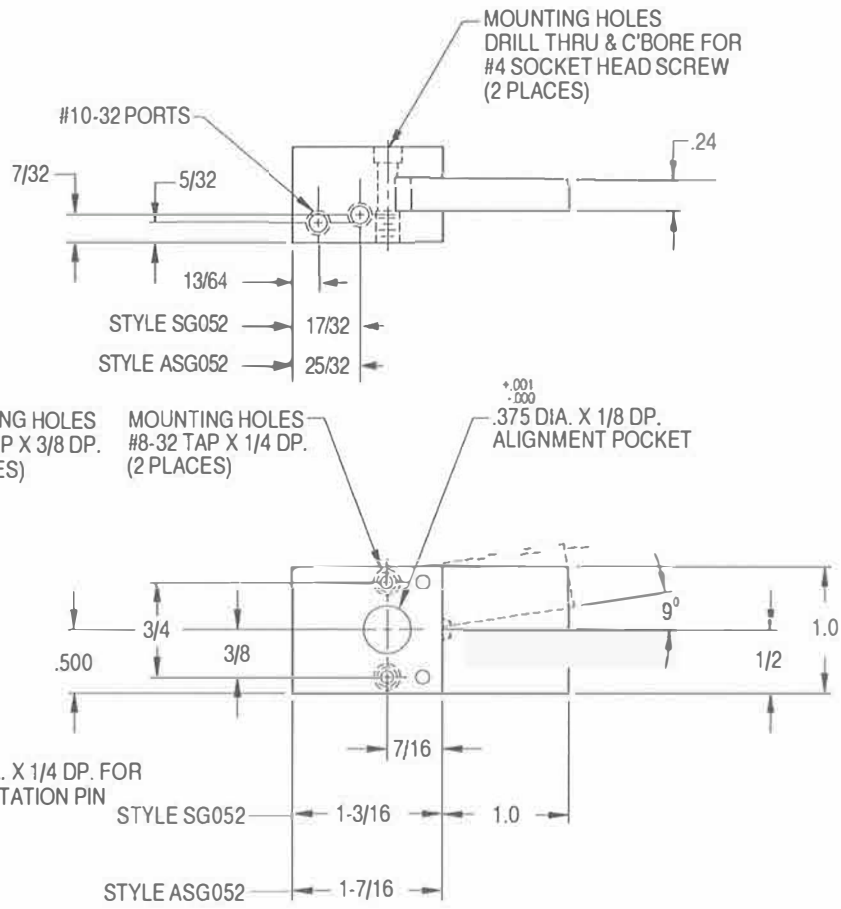

SENSOR MOUNTING TRACK (STYLE ASG052 ONLY) (DESIGN ACCOMMODATES ONE SENSOR ONLY)

ENGINEERING DATA

Gf = Gripping force
A = Distance from gripper face to centerline of gripped part (see sketch)

Theoretical Gripping Force Formula

$$Gf = \frac{F \times .375}{.156 + A}$$

ACTION	Piston Area in. ²
Push / Open	.2
Pull / Close	.15

QUICK REFERENCE CHART		
Dimension "A"	Action	Pre-Calculated Gripping Force At 100 PSI (Gf)
1/2"	PUSH / OPEN	11.43 lbs.
	PULL / CLOSE	8.57 lbs.
1"	PUSH / OPEN	6.48 lbs.
	PULL / CLOSE	4.86 lbs.
2"	PUSH / OPEN	3.47 lbs.
	PULL / CLOSE	2.61 lbs.

Note: Tooling over 2" long is *not* recommended

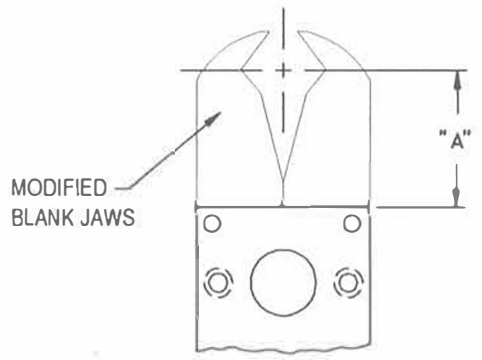

SECTION
A

**ANGULAR
MOTION
GRIPPERS**

**STYLE "RG" ROUND BODY GRIPPER
"RDG" ABOVE W/DOUBLE ROD
END ACTUATOR**
ALL DIMENSIONS IN INCHES

**2
JAW**

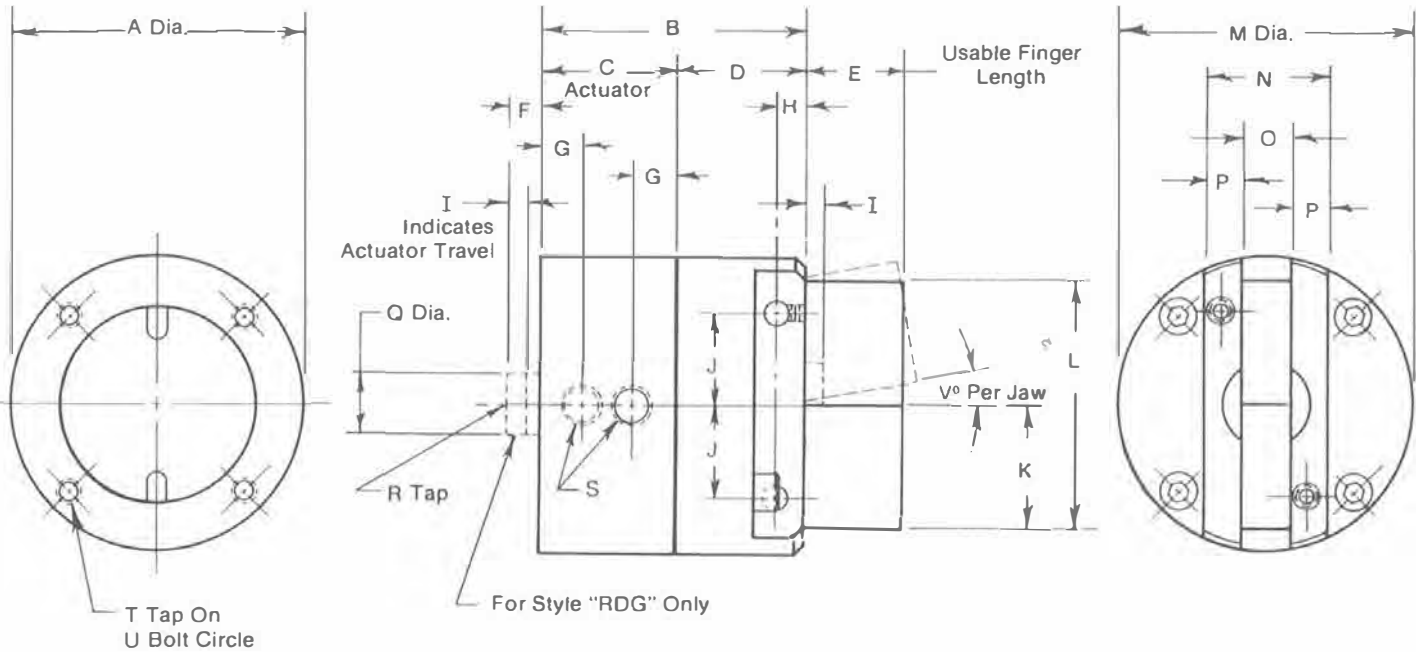

BORE	PART #	A	B	C	D	E	F	G	H	I	J	K	L	M	N	O	P	Q	R	S	T	U	V°
3/4"	072	1-1/2"	1-9/16"	7/8"	11/16"	SEE NOTE NUMBER 2 BELOW	3/16"	9/32"	3/16"	1/8"	7/16"	5/8"	1-1/4"	1-1/2"	29/32"	.240	21/64"	5/16"	10-24 x 1/2"	* 10-32	10-24 x 7/16"	1-1/8"	14°
1-1/8"	112	1-7/8"	1-7/8"	7/8"	1"		1/4"	9/32"	15/64"	1/8"	9/16"	3/4"	1-1/2"	1-7/8"	1-5/32"	.365	25/64"	1/2"	5/16-18 x 5/8"	1/8-27	10-24 x 7/16"	1-1/2"	10°
1-5/8"	162	2-3/8"	2-7/16"	1-1/8"	1-5/16"		1/4"	13/32"	9/32"	1/8"	3/4"	1"	2"	2-3/8"	1-15/32"	.490	31/64"	5/8"	3/8-16 x 7/8"	1/8-27	10-24 x 7/16"	2"	8°
2"	202	3"	2-11/16"	1-3/8"	1-5/16"		3/8"	7/16"	9/32"	1/4"	15/16"	1-1/4"	2-1/2"	3"	1-1/4"	.490	3/8"	5/8"	3/8-16 x 7/8"	1/8-27	1/4-20 x 5/8"	2-1/2"	14°
2-1/2"	252	3-1/2"	3-1/4"	1-1/2"	1-3/4"		3/8"	1/2"	15/32"	1/4"	1-3/16"	1-1/2"	3	3-1/2"	2-1/32"	.615	45/64"	3/4"	1/2-13 x 1"	** 1/8-27	1/4-20 x 5/8"	3"	11°
3"	302	4"	3-1/2"	1-3/4"	1-3/4"		3/8"	9/16"	15/32"	1/4"	1-7/16"	2"	4"	4"	2"	.615	11/16"	3/4"	1/2-13 x 1-1/8"	** 1/8-27	5/16-18 x 3/4"	3-1/2"	9°
4"	402	5"	4-1/8"	2"	2-1/8"		1/2"	21/32"	37/64"	3/8"	1-7/8"	2-1/2"	5"	5"	2-1/2"	.990	3/4"	3/4"	1/2-13 x 1-5/16"	** 1/8-27	5/16-18 x 3/4"	4-1/2"	10°
4"	412	5"	4-1/8"	2"	2-1/8"		1/2"	21/32"	37/64"	3/8"	2-3/8"	3"	6"	6"	2-1/2"	.990	3/4"	3/4"	1/2-13 x 1-5/16"	** 1/8-27	5/16-18 x 3/4"	4-1/2"	8°
5"	502	6"	4-1/4"	2-1/8"	2-1/8"		1/2"	21/32"	37/64"	3/8"	2-3/8"	3"	6"	6"	2-1/2"	.990	3/4"	3/4"	1/2-13 x 1-3/8"	** 1/8-27	5/16-18 x 3/4"	5-1/2"	8°
6"	602	SEE NOTE #4 BELOW																					
8"	802	SEE NOTE #4 BELOW																					

*1/8-27 Pipe Tap Optional

**1/4-18 Pipe Tap Optional

NOTES:	
#1	Ports are 180° apart. Consult factory for other Port locations. Head can be indexed 90°.
#2	See chart on Page 9 for stock finger lengths. Stock fingers are in blank form to be modified. Specials welcome.
#3	Gripping force calculations on Pages 2 & 3.
#4	Due to a different pivot design on "602" & "802" sizes, above tabulated drawing does not apply. Consult factory for drawings.

SECTION

A

**ANGULAR
MOTION
GRIPPERS**

**STYLE "SG" SQUARE BODY GRIPPER
"SDG" ABOVE W/DOUBLE ROD
END ACTUATOR**

**2
JAW**

ALL DIMENSIONS IN INCHES

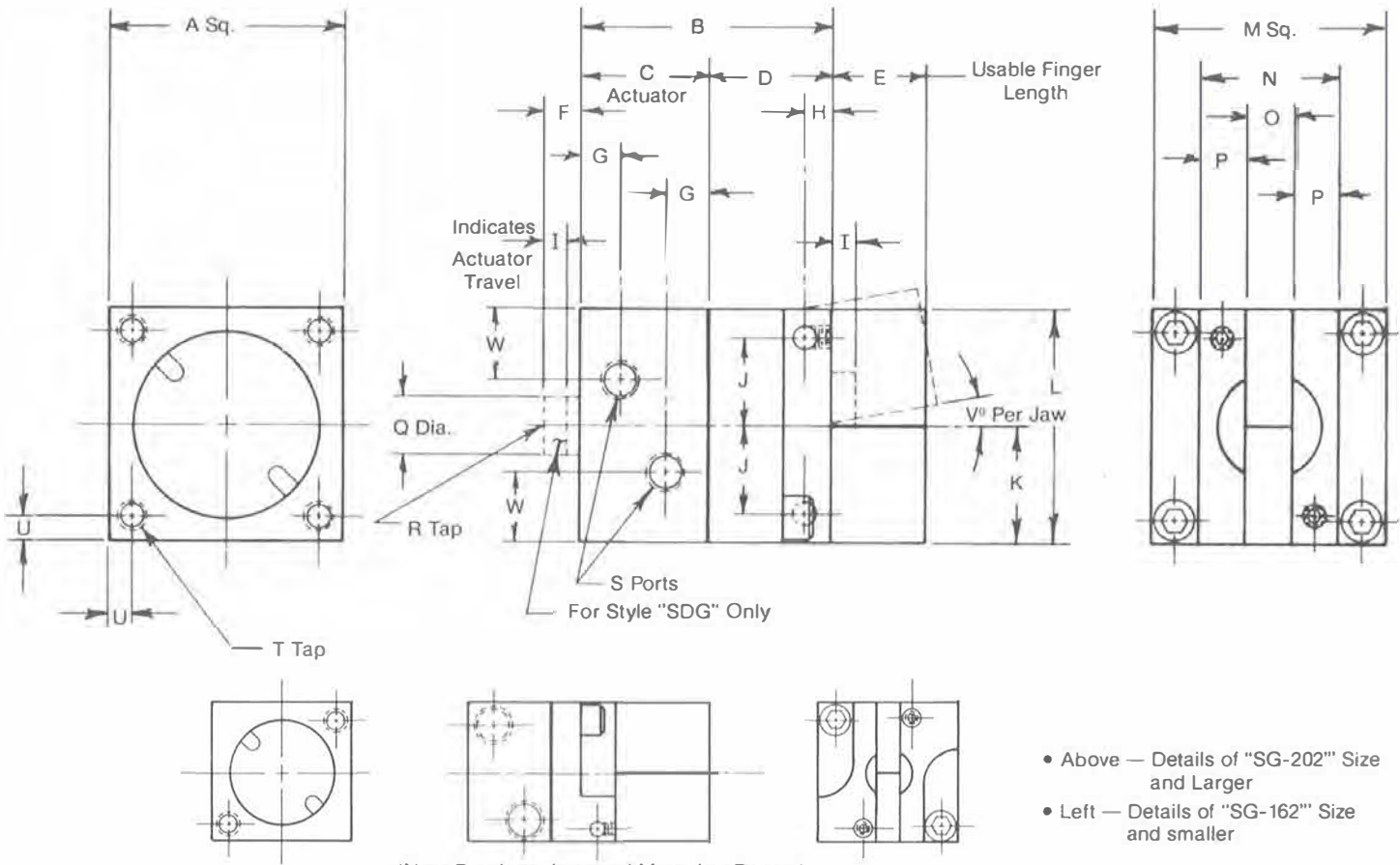

- Above — Details of "SG-202" Size and Larger
- Left — Details of "SG-162" Size and smaller

(Note Port Locations and Mounting Pattern)

BORE	PART #	A	B	C	D	E	F	G	H	I	J	K	L	M	N	O	P	Q	R	S	T	U	V°	W
3/4"	072	1-1/4"	1-9/16"	7/8"	11/16"	SEE NOTE NUMBER 2 BELOW	3/16"	9/32"	3/16"	1/8"	7/16"	5/8"	1-1/4"	1-1/4"	7/8"	.240	1/8"	5/16"	10-24 x 1/2"	* 10-32	1/4-20 x 7/16"	3/16"	14°	5/16"
1-1/8"	112	1-1/2"	1-7/8"	7/8"	1"		1/4"	9/32"	15/64"	1/8"	9/16"	3/4"	1-1/2"	1-1/2"	1-9/64"	.365	13/64"	1/2"	5/16-18 x 5/8"	1/8-27	1/4-20 x 7/16"	3/16"	10°	1/4"
1-5/8"	162	2"	2-7/16"	1-1/8"	1-5/16"		1/4"	13/32"	9/32"	1/8"	3/4"	1"	2"	2"	1-9/16"	.490	5/16"	5/8"	3/8-16 x 5/8"	1/8-27	1/4-20 x 9/16"	1/4"	8°	5/16"
2"	202	2-1/2"	2-11/16"	1-3/8"	1-5/16"		3/8"	7/16"	9/32"	1/4"	15/16"	1-1/4"	2-1/2"	2-1/2"	1-1/2"	.490	1/2"	5/8"	3/8-16 x 7/8"	1/8-27	5/16-18 x 11/16"	1/4"	14°	3/4"
2-1/2"	252	3"	3-1/4"	1-1/2"	1-3/4"		3/8"	1/2"	15/32"	1/4"	1-3/16"	1-1/2"	3"	3"	1-13/16"	.615	19/32"	3/4"	1/2-13 x 7/8"	1/8-27	3/8-16 x 3/4"	5/16"	11°	3/4"
3"	302	3-1/2"	3-1/2"	1-3/4"	1-3/4"		3/8"	9/16"	15/32"	1/4"	1-7/16"	2"	4"	3-1/2"	2-1/4"	.615	13/16"	3/4"	1/2-13 x 1-1/8"	** 1/8-27	3/8-16 x 7/8"	5/16"	9°	13/16"

*1/8-27 Pipe Tap Optional

**1/4-1/8 Pipe Tap Optional

NOTES:	
#1	3/4" to 1-5/8" bore have ports 180° apart and 2 MTG holes. 2" bore and up have ports on same side and 4 MTG holes. Other porting, consult factory.
#2	See chart on Page 9 for stock finger lengths. Stock fingers are in blank form to be modified. Specials welcome.
#3	Gripping force calculations on Pages 2 & 3.

SECTION

A

**ANGULAR
MOTION
GRIPPERS**

**STYLE "BG" BASE MOUNT
SQUARE BODY GRIPPERS
"BDG" ABOVE W/DOUBLE ROD
END ACTUATOR**
ALL DIMENSIONS IN INCHES

**2
JAW**

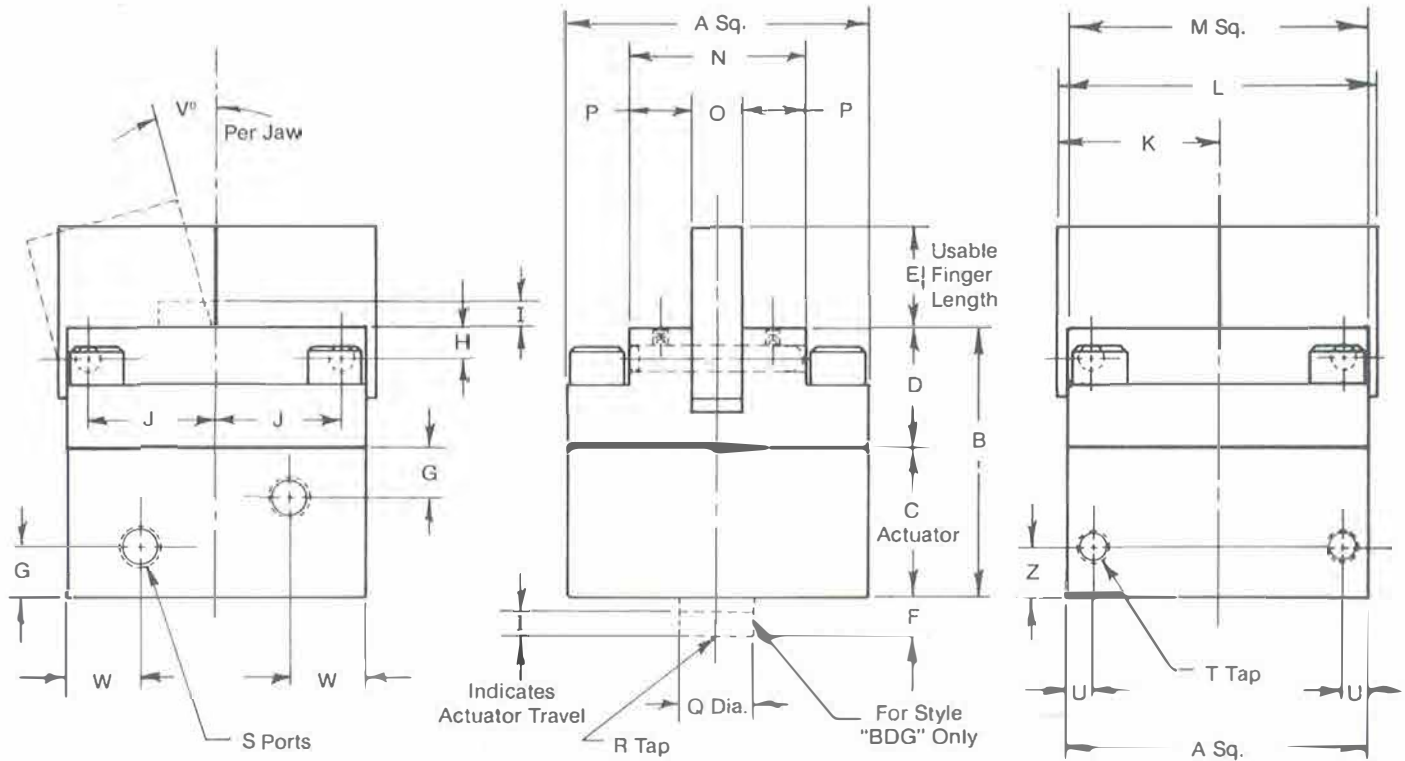

BORE	PART #	A	B	C	D	E	F	G	H	I	J	K	L	M	N	O	P	Q	R	S	T	U	V ^o	W	Z
3/4"	072	1-1/4"	1-9/16"	7/8"	11/16"	SEE NOTE NUMBER 2 BELOW	3/16"	9/32"	3/16"	1/8"	7/16"	5/8"	1-1/4"	1-1/4"	7/8"	.240	1/8"	5/16"	10-24 x 1/2"	* 10-32	10-24 x 1/4"	3/16"	14 ^o	5/16"	3/8"
1-1/8"	112	1-1/2"	1-7/8"	7/8"	1"	SEE NOTE NUMBER 2 BELOW	1/4"	9/32"	15/64"	1/8"	9/16"	3/4"	1-1/2"	1-1/2"	1-9/64"	.365	13/64"	1/2"	5/16-18 x 5/8"	1/8-27	10-24 x 1/4"	3/16"	10 ^o	1/4"	3/8"
1-5/8"	162	2"	2-7/16"	1-1/8"	1-5/16"	SEE NOTE NUMBER 2 BELOW	1/4"	13/32"	9/32"	1/8"	3/4"	1"	2"	2"	1-9/16"	.490	5/16"	5/8"	3/8-16 x 5/8"	1/8-27	1/4-20 x 5/16"	1/4"	8 ^o	5/16"	1/2"
2"	202	2-1/2"	2-11/16"	1-3/8"	1-5/16"	SEE NOTE NUMBER 2 BELOW	3/8"	7/16"	9/32"	1/4"	15/16"	1-1/4"	2-1/2"	2-1/2"	1-1/2"	.490	1/2"	5/8"	3/8-16 x 7/8"	1/8-27	5/16-18 x 1/2"	1/4"	14 ^o	3/4"	1/2"
2-1/2"	252	3"	3-1/4"	1-1/2"	1-3/4"	SEE NOTE NUMBER 2 BELOW	3/8"	1/2"	15/32"	1/4"	1-3/16"	1-1/2"	3"	3"	1-13/16"	.615	19/32"	3/4"	1/2-13 x 7/8"	1/8-27	5/16-18 x 5/8"	1/4"	11 ^o	3/4"	1/2"
3"	302	3-1/2"	3-1/2"	1-3/4"	1-3/4"	SEE NOTE NUMBER 2 BELOW	3/8"	9/16"	15/32"	1/4"	1-7/16"	2"	4"	3-1/2"	2-1/4"	.615	13/16"	3/4"	1/2-13 x 1-1/8"	** 1/8-27	3/8-16 x 3/4"	5/16"	9 ^o	13/16"	5/8"

*1/8-27 Pipe Tap Optional

**1/4-1/8 Pipe Tap Optional

NOTES:	
#1	All ports located on same side, diagonal to each other. Other port locations available — Consult Factory.
#2	See chart on Page 9 for stock finger lengths. Stock fingers are in blank form to be modified. Specials welcome.
#3	Gripping force calculations on Pages 2 & 3.

SECTION

A

**ANGULAR
MOTION
GRIPPERS**

**STYLE "RG" ROUND BODY GRIPPER
"RDG" ABOVE W/DOUBLE ROD
END ACTUATOR**

ALL DIMENSIONS IN INCHES

**3
JAW**

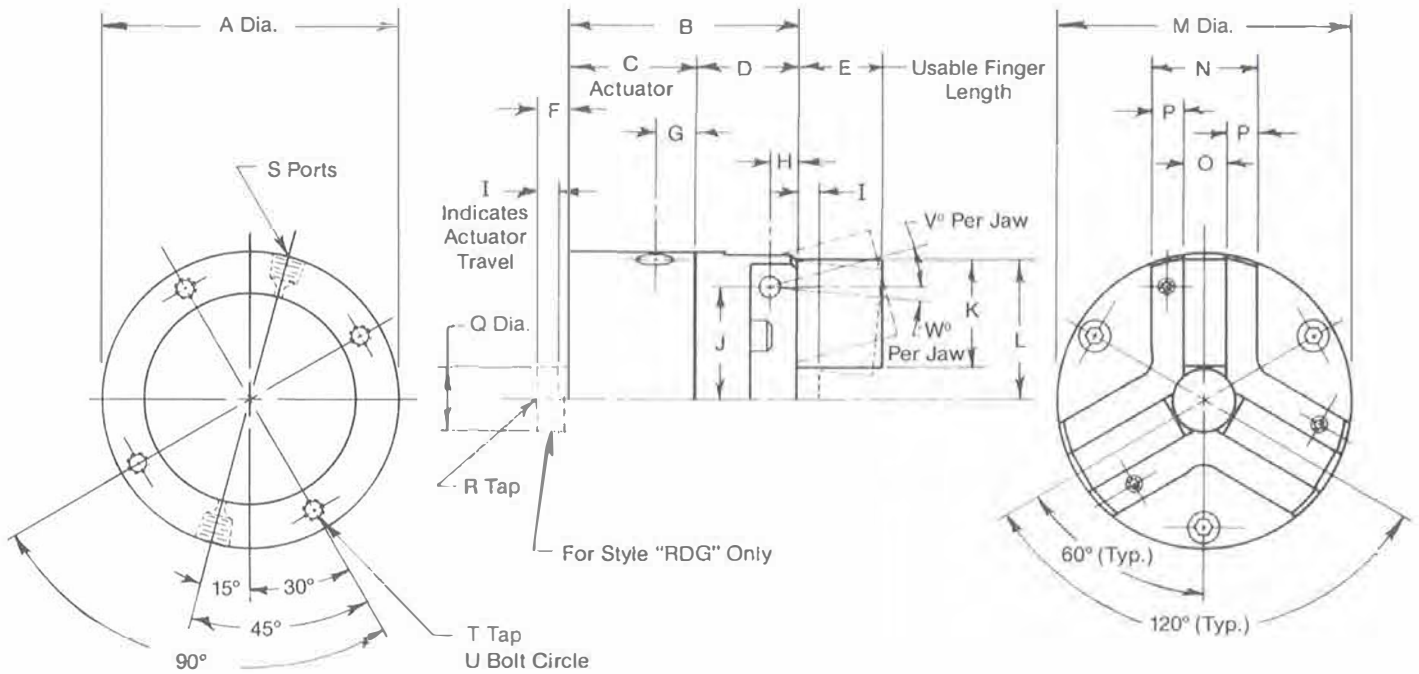

SPECIALS WELCOME — Materials, Custom Jaws, Jaw Opening, Etc.

BORE	PART #	A	B	C	D	E	F	G	H	I	J	K	L	M	N	O	P	Q	R	S	T	U	V°	W°
3/4"	073	1-1/2"	1-1/2"	13/16"	11/16"	SEE NOTE	1/8"	9/32"	3/16"	1/16"	31/64"	1/2"	43-64"	1-1/2"	3/4"	.240	1/4"	5/16"	10-24 x 1/4"	* 10-32	10-24 x 3/8"	1-1/8"	10°	2°
1-1/8"	113	1-7/8"	1-9/16"	7/8"	11/16"	NOTE	1/4"	9/32"	3/16"	1/8"	37/64"	1/2"	49/64"	1-7/8"	3/4"	.240	1/4"	1/2"	5/16-18 x 5/16"	1/8-27	10-24 x 3/8"	1-1/2"	10°	2°
1-5/8"	163	2-3/8"	2-1/16"	1-1/8"	15/16"	NUMBER	1/4"	13/32"	1/4"	1/8"	57/64"	3/4"	1-5/64"	2-3/8"	1	.365	5/16"	5/8"	3/8-16 x 7/16"	1/8-27	10-24 x 9/16"	2"	10°	2°
2-1/2"	253	3-1/2"	2-11/16"	1-1/2"	1-3/16"	2	3/8"	1/2"	5/16"	1/4"	1-21/64"	1-1/4"	1-41/64"	3-1/2"	1-1/4	.490	3/8"	3/4"	1/2-13 x 5/8"	** 1/8-27	1/4-20 x 3/4"	3"	13°	2°
3"	303	4"	3"	1-3/4"	1-1/4"	2	3/8"	9/16"	5/16"	1/4"	1-21/64"	1-1/4"	1-41/64"	4"	1-1/2"	.490	1/2"	3/4"	1/2-13 x 5/8"	** 1/8-27	5/16-18 x 3/4"	3-1/2"	13°	2°
4"	403	5"	3-3/4"	2"	1-3/4"	2	1/2"	21/32"	1/2"	3/8"	1-61/64"	2"	2-33/64"	5"	2"	.615	11/16"	1"	1/2-13 x 3/4"	** 1/8-27	5/16-18 x 3/4"	4-1/2"	13°	2°
5"	503	6"	4-1/4"	2-1/8"	2-1/8"	2	1/2"	21/32"	5/8"	3/8"	2-33/64"	2-1/2"	3-9/64"	6"	2"	.990	1/2"	1-1/4"	1/2-13 x 3/4"	** 1/8-27	5/16-18 x 3/4"	5-1/2"	10°	2°
6"	603	7"	4-5/8"	2-1/2"	2-1/8"	2	5/8"	25/32"	5/8"	1/2"	3-1/64"	3"	3-41/64"	7"	2"	.990	1/2"	1-1/4"	1/2-13 x 1"	** 1/8-27	5/16-18 x 3/4"	6-1/2"	10°	2°
8"	803	9"	5-3/8"	3"	2-3/8"	2	7/8"	25/32"	13/16"	3/4"	3-33/64"	3-1/2"	4-17/64"	9"	3"	.990	1"	1-1/2"	1/2-13 x 1"	** 1/8-27	5/16-18 x 3/4"	8-1/2"	14°	2°

*1/8-27 Pipe Tap Optional

**1/4-1/8 Pipe Tap Optional

NOTES:	
#1	Ports are 180° apart — Gripping force calculations on Pages 2 & 3.
#2	See Page 9 for stock Jaw lengths. Stock Jaws are in blank form to be modified. Specials welcome.

BLANK JAWS — STOCK LENGTHS

2 JAW

STOCK BLANK JAW LENGTHS				
BORE	SERIES	STOCK LENGTHS		
1/2"	052	1/2"	1"	—
3/4"	072	1"	2"	3"
1-1/8"	112	1"	2"	3"
1-5/8"	162	1"	2"	3"
2"	202	1"	2"	3"
2-1/2"	252	1"	3"	5"
3"	302	1"	3"	5"
4"	402	1"	3"	5"
4"	412	1"	3"	5"
5"	502	1"	3"	5"
6"	602	1"	3"	5"
8"	802	1"	3"	5"

3 JAW

STOCK BLANK JAW LENGTHS				
BORE	SERIES	STOCK LENGTHS		
3/4"	073	1"	2"	3"
1-1/8"	113	1"	2"	3"
1-5/8"	163	1"	2"	3"
2-1/2"	253	1"	2"	3"
3"	303	1"	3"	5"
4"	403	1"	3"	5"
5"	503	1"	3"	5"
6"	603	1"	3"	5"
8"	803	1"	3"	5"

See page 10 for ordering instructions

OPTION

Any Com-Pick gripper may be purchased with or without jaws. Pivot drawings available to aid in the designing of your own tooling. Consult the factory or your local distributor.

TOOLING ONLY

To order a "set" of jaws only:

Specify: F 112 A 2

Series required	Length in inches
--------------------	---------------------

NOTE: 1) Blank jaws are made of "1018" free machining steel 2) Other materials, lengths and configurations available - consult factory or local distributor

See Page 18, Section D, for Application Ideas on Blank Jaws

OPTION "PA" Positive Alignment Pocket

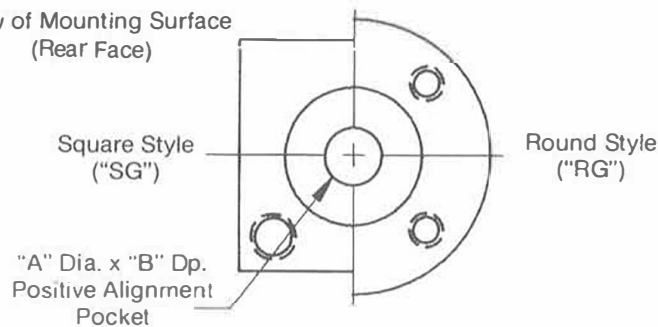
View of Mounting Surface
(Rear Face)

BORE	1/2"	3/4"	1-1/8"	1-5/8"	2"	2-1/2"	3	4	5	6	8
"A"	.250	.312	.500	.625	.750	.750	1.500	1.500	1.500	1.500	1.500
"B"	1/16	1/8	1/8	3/16	1/4	1/4	5/16	5/16	5/16	5/16	5/16

NOTES: 1. "PA" Option not available on base style grippers. Consult factory for positive alignment mounting on base style. (BG/BDG)
2. Not available on double rod end actuators. (Use Shaft.)

PRE-MODIFIED "L" JAW

OPTION # "LJ"

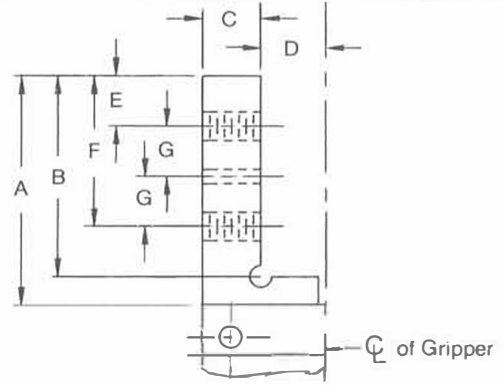

TOOLING ONLY

To order a "set" of jaws only:

Specify: F 112 ALJ

Series required

Special Step Fingers for 2 & 3 Jaw Angular Grippers

2 JAW GRIPPERS

SERIES	A	B	C	D	E	F	G	H	I	J	K*
052	1	7/8	1/4	1/4	1/4	5/8	N/A	N/A	#8-32	#5	1/4
072	1	7/8	1/4	3/8	1/4	5/8	N/A	N/A	#8-32	#5	1/4
112	1	7/8	3/8	3/8	1/4	5/8	N/A	N/A	#10-24	#6	3/8
162	2	1-3/4	1/2	1/2	7/16	1-5/16	7/16	#31 (.120)	1/4-20	#10	1/2
202	2	1-3/4	1/2	3/4	7/16	1-5/16	7/16	#31 (.120)	1/4-20	#10	1/2
252	3	2-3/4	3/4	3/4	5/8	2-1/8	3/4	15/64	5/16-18	1/4	5/8
302	3	2-3/4	3/4	1-1/4	5/8	2-1/8	3/4	15/64	5/16-18	1/4	5/8
402	3	2-3/4	1	1-1/2	5/8	2-1/8	3/4	15/64	5/16-18	1/4	1
412/502	3	2-3/4	1	2	5/8	2-1/8	3/4	15/64	5/16-18	1/4	1

3 JAW GRIPPERS

SERIES	A	B	C	D	E	F	G	H	I	J	K*
073	1	7/8	1/4	27/64	1/4	5/8	N/A	N/A	8-32	#5	1/4
113	1	7/8	1/4	33/64	1/4	5/8	N/A	N/A	8-32	#5	1/4
163	1	7/8	3/8	45/64	1/4	5/8	N/A	N/A	10-24	#6	3/8
253	2	1-3/4	1/2	1-9/64	7/16	1-5/16	7/16	#31 (.120)	1/4-20	#10	1/2
303	2	1-3/4	1/2	1-9/64	7/16	1-5/16	7/16	#31 (.120)	1/4-20	#10	1/2
403	3	2-3/4	3/4	1-49/64	5/8	2-1/8	3/4	15/64	5/16-18	#1/4	5/8
503	3	2-3/4	1	2-9/64	5/8	2-1/8	3/4	15/64	5/16-18	#1/4	1

*K Dimension is ground .010 under fraction given

HOW TO ORDER

#A-SG-072-1-PA-HTV

A

For Magnetic Piston option only. See sensor Bulletin. Omit if not desired

SG

GRIPPER STYLE

Given at top of dimensional page.

072

SIZE AND NUMBER OF JAWS

BORE	2 JAW	3 JAW
1/2	052	—
3/4	072	073
1-1/8	112	113
1-5/8	162	163
2	202	—
2-1/2	252	253
3	302	303
4	402	403
4	412	—
5	502	503
6	602	603
8	802	803

1

-PA-HTV

JAW OPTIONS

No jaws required - simply omit code

Blank jaws required, specify length - see page 9 for stock sizes

Pre-modified jaws required, specify "LJ" - shown above

OPTION

Simply omit codes if no options or accessories are desired.

- See page 9 of this section, or section C.
- If P/N cannot easily identify your requirements, consult factory for special part number.

INTRODUCTION

TRUE PARALLEL MOTION GRIPPERS & ACCESSORIES

Parallel motion grippers represent a highly versatile and flexible design. The integral pneumatic cylinder pushes the jaws open. The jaws slide along two hardened guide rods providing rigid, long lasting true parallel motion. The pull stroke closes the jaws. A four-way valve circuit is required for control.

All units are of two jaw design.

Gripping forces, formulas, unit weights, and dimensions are included in this section.

ENGINEERING DATA

SELF CONTAINED ACTUATOR

All models feature Compact Air cylinder actuators as an integral, yet self-contained, component. Cylinders feature low profiles, low weight aluminum alloy bodies, and stainless steel piston rods. All units are pre-lubricated for life.

MATERIALS

Actuators are aluminum alloy with nylon rod bushings. All sliding parts are heat treated steel for long, trouble-free operation. Mechanism cover pieces are stamped stainless steel.

ACTUATOR SEALS

As standard, actuators are packed with seals of Buna-N rubber. Temperature limits are from 0° F to 200° F (-18° C to 90° C). All actuators are pre-lubricated at the factory and do not require additional lubrication.
Seal options — Section C.

TOOLING

Com-Pick II grippers are "generic" in standard form. Base jaws are slotted and tapped for tooling. Pre-modified "L" jaws and aluminum blanks are stocked or you can add your own V-blocks, pads, sensors, etc. Also, see Section D.

THEORETICAL GRIPPING FORCE FORMULAS

NOTE: Gripping forces are constant at any point of jaw travel. Due to friction caused by leverage, 7% to 10% force loss per inch of tooling length should be considered. Long jaw tooling will reduce the life of the gripper and is not recommended. Consult factory.

$$\text{GRIPPING FORCE} = \frac{\text{PSI} \times \text{PISTON AREA}}{2}$$

PISTON AREAS IN.²

BORE	SERIES	1/2		3/4		1-1/8		1-3/8		1-5/8		2"	
		052		072		112		132		162		202	
IN. ²	Push (Open)	.2		.44		1.0		1.5		2		3	
IN. ²	Pull (Close)	.15		.36		.8		1.2		1.7		2.7	

ENGINEERING DATA — Continued

PRESSURE RATINGS

PNEUMATIC	Clean, dry or lubricated — 15 PSI to 200 PSI (125 PSI In 052 series)
HYDRAULIC	Consult Factory

PRE-CALCULATED GRIPPING FORCES

GRIPPER		AIR PRESSURE (PSI)				
SERIES	BORE	20 PSI	40 PSI	60 PSI	80 PSI	100 PSI
052	1/2	2 Lbs.	4 Lbs.	6 Lbs.	8 Lbs.	10 Lbs.
		1.5 Lbs.	3 Lbs.	4.5 Lbs.	6 Lbs.	7.5 Lbs.
072	3/4	4.4 Lbs.	8.8 Lbs.	13.2 Lbs.	17.6 Lbs.	22 Lbs.
		3.6 Lbs.	7.2 Lbs.	10.8 Lbs.	14.4 Lbs.	18 Lbs.
112	1-1/8	10 Lbs.	20 Lbs.	30 Lbs.	40 Lbs.	50 Lbs.
		8 Lbs.	16 Lbs.	24 Lbs.	32 Lbs.	40 Lbs.
132	1-3/8	15 Lbs.	30 Lbs.	45 Lbs.	60 Lbs.	75 Lbs.
		12 Lbs.	24 Lbs.	36 Lbs.	48 Lbs.	60 Lbs.
162	1-5/8	20 Lbs.	40 Lbs.	60 Lbs.	80 Lbs.	100 Lbs.
		17 Lbs.	34 Lbs.	51 Lbs.	68 Lbs.	85 Lbs.
202	2"	30 Lbs.	60 Lbs.	90 Lbs.	120 Lbs.	150 Lbs.
		27 Lbs.	54 Lbs.	81 Lbs.	108 Lbs.	135 Lbs.

 — Open — I.D. Gripping

 — Closed — O.D. Gripping

★ IMPORTANT NOTES ★

- Gripping forces are theoretical and will vary due to friction. 7% to 10% force reduction per inch of tooling length is approximate force loss.
- Long, heavy tooling decreases performance of the gripper and should be avoided.

Maximum recommended tooling length:

- Series 052, 072 and 112 = 2"
- Series 132, 162 and 202 = 5"

ESTIMATED UNIT WEIGHTS Without Tooling (Lbs)

SERIES	052	072	112	132	162	202
Short Travel	.21	.60	.95	2.05	2.20	2.65
Long Travel	.25	.70	1.10	2.30	2.45	2.95

DOUBLE ROD END ACTUATORS

Unlike the angular type grippers, Double Rod End Actuators are not stocked for Parallel Grippers due to the extra length the double ended rod adds in the longer strokes required for parallel gripping. Double Rod End Actuators can be special ordered. Primary application for this option is limit sensing w/mechanical switches. See section C for Solid State Piston Sensors.

SECTION
B

**TRUE
PARALLEL
MOTION
GRIPPERS**

**STYLE "PSG" SQUARE BODY GRIPPERS
(END/REAR FACE MOUNTED)**

**2
JAW**

ALL DIMENSIONS IN INCHES

IMPORTANT NOTE: Unit mounting holes are **ONLY** difference between styles "PSG" & "PBG"

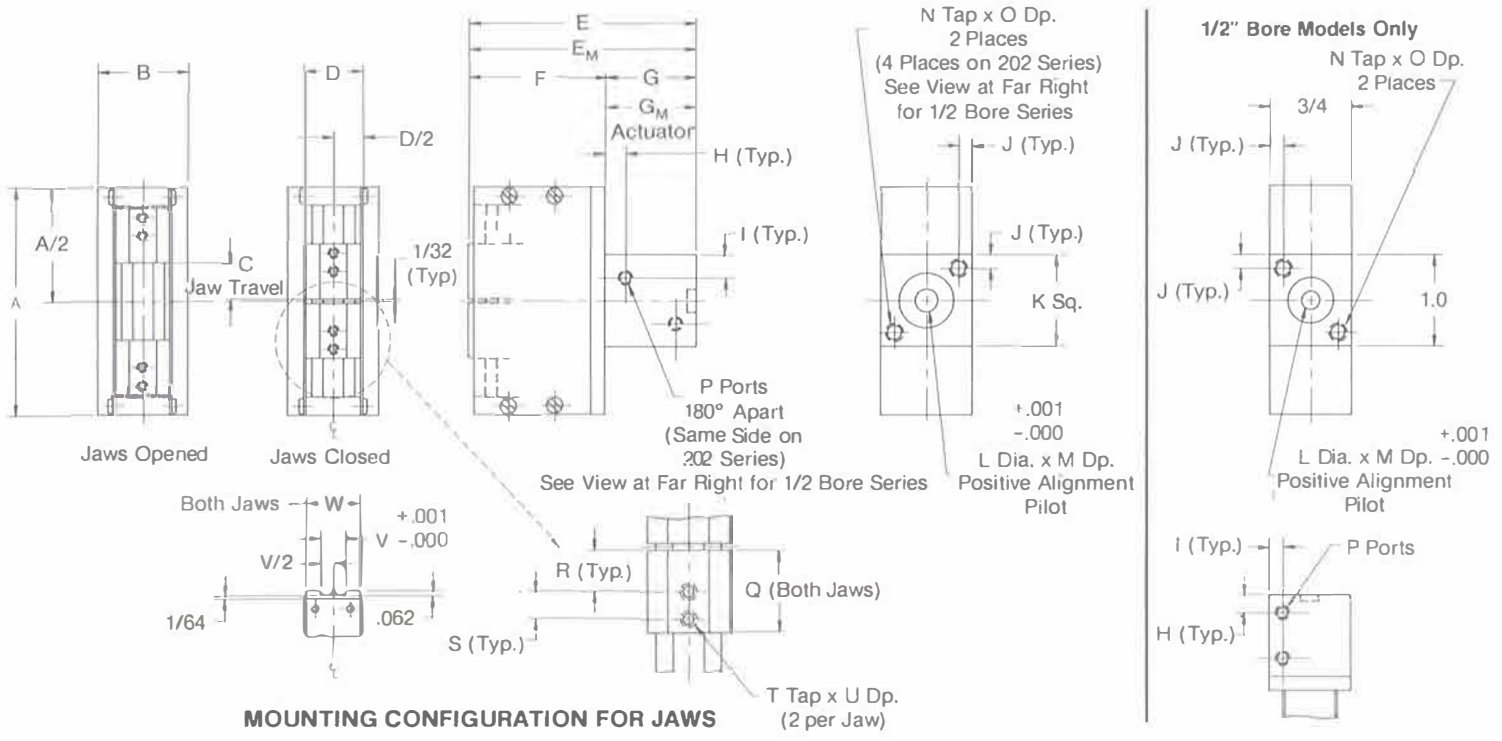

BORE	GRIPPER	PART #	A	B	C	D	E	**E _M	F	G	**G _M	H	I	J	K	L	M
1/2"	Square 1/2 Bore x 1/8 Jaw Travel	PSG052 x 1/8	1-7/8	3/4	1/8	9/16	1-3/4	2.0	1.0	3/4	1.0	13/64	5/32	9/64	1.0	.250	1/16
	Square 1/2 Bore x 1/4 Jaw Travel	PSG052 x 1/4	2-1/8	3/4	1/4	9/16	2-1/8	2-3/8	1-1/4	7/8	1-1/8	13/64	5/32	9/64	1.0	.250	1/16
3/4"	Square 3/4 Bore x 1/4 Jaw Travel	PSG072 x 1/4	2-5/8	1-1/4	1/4	13/16	2-3/8	2-5/8	1-3/8	1.0	1-1/4	9/32	5/16	3/16	1-1/4	.312	1/8
	Square 3/4 Bore x 1/2 Jaw Travel	PSG072 x 1/2	3-1/8	1-1/4	1/2	13/16	3.0	3-1/4	1-3/4	1-1/4	1-1/2	9/32	5/16	3/16	1-1/4	.312	1/8
1-1/8"	Square 1-1/8 Bore x 1/4 Jaw Travel	PSG112 x 1/4	3-1/8	1-1/2	1/4	1-1/16	2-5/8	2-7/8	1-5/8	1.0	1-1/4	9/32	1/4	3/16	1-1/2	.500	1/8
	Square 1-1/8 Bore x 1/2 Jaw Travel	PSG112 x 1/2	3-5/8	1-1/2	1/2	1-1/16	3-1/4	3-1/2	2.0	1-1/4	1-1/2	9/32	1/4	3/16	1-1/2	.500	1/8
1-3/8"	Square 1-3/8 Bore x 1/2 Jaw Travel	PSG132 x 1/2	4-1/8	1-3/4	1/2	1-5/16	3-15/16	4-3/16	2-7/16	1-1/2	1-3/4	13/32	5/16	7/32	1-3/4	.625	3/16
	Square 1-3/8 Bore x 3/4 Jaw Travel	PSG132 x 3/4	4-5/8	1-3/4	3/4	1-5/16	4-9/16	4-13/16	2-13/16	1-3/4	2.0	13/32	5/16	7/32	1-3/4	.625	3/16
1-5/8"	Square 1-5/8 Bore x 1/2 Jaw Travel	PSG162 x 1/2	4-1/8	2.0	1/2	1-5/16	3-15/16	4-3/16	2-7/16	1-1/2	1-3/4	13/32	5/16	1/4	2.0	.625	3/16
	Square 1-5/8 Bore x 3/4 Jaw Travel	PSG162 x 3/4	4-5/8	2.0	3/4	1-5/16	4-9/16	4-13/16	2-13/16	1-3/4	2.0	13/32	5/16	1/4	2.0	.625	3/16
2"	Square 2.0 Bore x 1/2 Jaw Travel	PSG202 x 1/2	4-1/8	2-1/2	1/2	1-5/16	4-1/16	4-5/16	2-7/16	1-5/8	1-7/8	7/16	3/4	1/4	2-1/2	.750	1/4
	Square 2.0 Bore x 3/4 Jaw Travel	PSG202 x 3/4	4-5/8	2-1/2	3/4	1-5/16	4-11/16	4-15/16	2-13/16	1-7/8	2-1/8	7/16	3/4	1/4	2-1/2	.750	1/4

BORE	PART #	N	O	P	Q	R	S	T	U	V	W
1/2"	PSG052 x 1/8	#6-32	5/16	#10-32	1/2	1/4	5/32	#4-40	7/32	.250	.480
	PSG052 x 1/4	#6-32	3/8	#10-32	1/2	1/4	5/32	#4-40	7/32	.250	.480
3/4"	PSG072 x 1/4	#1/4-20	1/2	#10-32*	3/4	3/8	1/4	#6-32	3/16	.375	.730
	PSG072 x 1/2	#1/4-20	1/2	#10-32*	3/4	3/8	1/4	#6-32	3/16	.375	.730
1-1/8"	PSG112 x 1/4	#1/4-20	1/2	#1/8-27	1.0	1/2	5/16	#6-32	1/4	.500	.980
	PSG112 x 1/2	#1/4-20	1/2	#1/8-27	1.0	1/2	5/16	#6-32	1/4	.500	.980
1-3/8"	PSG132 x 1/2	#1/4-20	1/2	#1/8-27	1-1/4	5/8	3/8	#10-24	3/8	.625	1.230
	PSG132 x 3/4	#1/4-20	1/2	#1/8-27	1-1/4	5/8	3/8	#10-24	3/8	.625	1.230
1-5/8"	PSG162 x 1/2	#1/4-20	1/2	#1/8-27	1-1/4	5/8	3/8	#10-24	3/8	.625	1.230
	PSG162 x 3/4	#1/4-20	1/2	#1/8-27	1-1/4	5/8	3/8	#10-24	3/8	.625	1.230
2"	PSG202 x 1/2	#5/16-18	5/8	#1/8-27	1-1/4	5/8	3/8	#10-24	3/8	.625	1.230
	PSG202 x 3/4	#5/16-18	5/8	#1/8-27	1-1/4	5/8	3/8	#10-24	3/8	.625	1.230

* 1/8-27 Pipe Tap, Optional

** For magnetic piston, specify suffix "A". Refer to page 17 for track locations or see our Comtronic® Limit Sensor catalog for additional sensor information.



P.O. Box 499 • Westminster, SC 29693-0499
Phone: (864) 647-9521
Fax No.: (864) 647-9574

SECTION
B

**TRUE
PARALLEL
MOTION
GRIPPERS**

**STYLE "PBG" BASE MOUNTED GRIPPER
(SQUARE BODY
W/BASE MTG HOLES)**

**2
JAW**

ALL DIMENSIONS IN INCHES

IMPORTANT NOTE: Unit mounting holes are **ONLY** difference between styles "PBG" & "PSG"

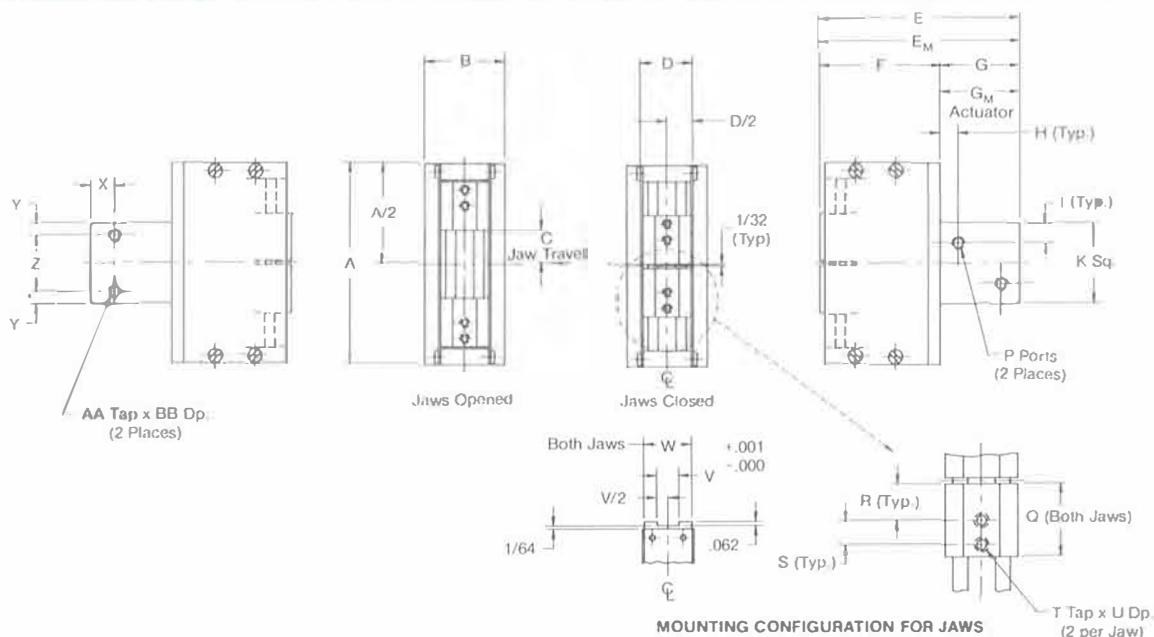

BORE	GRIPPER	PART #	A	B	C	D	E	**E _M	F	G	**G _M	H	I	K
3/4"	Base 3/4 Bore x 1/4 Jaw Travel	PBG072 x 1/4	2-5/8	1-1/4	1/4	13/16	2-3/8	2-5/8	1-3/8	1.0	1-1/4	9/32	5/16	1-1/4
	Base 3/4 Bore x 1/2 Jaw Travel	PBG072 x 1/2	3-1/8	1-1/4	1/2	13/16	3.0	3-1/4	1-3/4	1-1/4	1-1/2	9/32	5/16	1-1/4
1-1/8"	Base 1-1/8 Bore x 1/4 Jaw Travel	PBG112 x 1/4	3-1/8	1-1/2	1/4	1-1/16	2-5/8	2-7/8	1-5/8	1.0	1-1/4	9/32	1/4	1-1/2
	Base 1-1/8 Bore x 1/2 Jaw Travel	PBG112 x 1/2	3-5/8	1-1/2	1/2	1-1/16	3-1/4	3-1/2	2.0	1-1/4	1-1/2	9/32	1/4	1-1/2
1-3/8"	Base 1-3/8 Bore x 1/2 Jaw Travel	PBG132 x 1/2	4-1/8	1-3/4	1/2	1-5/16	3-15/16	4-3/16	2-7/16	1-1/2	1-3/4	13/32	5/16	1-3/4
	Base 1-3/8 Bore x 3/4 Jaw Travel	PBG132 x 3/4	4-5/8	1-3/4	3/4	1-5/16	4-9/16	4-13/16	2-13/16	1-3/4	2.0	13/32	5/16	1-3/4
1-5/8"	Base 1-5/8 Bore x 1/2 Jaw Travel	PBG162 x 1/2	4-1/8	2.0	1/2	1-5/16	3-15/16	4-3/16	2-7/16	1-1/2	1-3/4	13/32	5/16	2.0
	Base 1-5/8 Bore x 3/4 Jaw Travel	PBG162 x 3/4	4-5/8	2.0	3/4	1-5/16	4-9/16	4-13/16	2-13/16	1-3/4	2.0	13/32	5/16	2.0
2"	Base 2.0 Bore x 1/2 Jaw Travel	PBG202 x 1/2	4-1/8	2-1/2	1/2	1-5/16	4-1/16	4-5/16	2-7/16	1-5/8	1-7/8	7/16	3/4	2-1/2
	Base 2.0 Bore x 3/4 Jaw Travel	PBG202 x 3/4	4-5/8	2-1/2	3/4	1-5/16	4-11/16	4-15/16	2-13/16	1-7/8	2-1/8	7/16	3/4	2-1/2

BORE	PART #	P	Q	R	S	T	U	V	W	X	Y	Z	AA	BB
3/4"	PBG072 x 1/4	#10-32*	3/4	3/8	1/4	#6-32	3/16	.375	.730	3/8	3/16	7/8	#10-24	5/16
	PBG072 x 1/2	#10-32*	3/4	3/8	1/4	#6-32	3/16	.375	.730	3/8	3/16	7/8	#10-24	5/16
1-1/8"	PBG112 x 1/4	#1/8-27	1.0	1/2	5/16	#6-32	1/4	.500	.980	3/8	3/16	1-1/8	#10-24	5/16
	PBG112 x 1/2	#1/8-27	1.0	1/2	5/16	#6-32	1/4	.500	.980	3/8	3/16	1-1/8	#10-24	5/16
1-3/8"	PBG132 x 1/2	#1/8-27	1-1/4	5/8	3/8	#10-24	3/8	.625	1.230	1/2	1/4	1-1/4	#10-24	5/16
	PBG132 x 3/4	#1/8-27	1-1/4	5/8	3/8	#10-24	3/8	.625	1.230	1/2	1/4	1-1/4	#10-24	5/16
1-5/8"	PBG162 x 1/2	#1/8-27	1-1/4	5/8	3/8	#10-24	3/8	.625	1.230	1/2	1/4	1-1/2	#1/4-20	3/8
	PBG162 x 3/4	#1/8-27	1-1/4	5/8	3/8	#10-24	3/8	.625	1.230	1/2	1/4	1-1/2	#1/4-20	3/8
2"	PBG202 x 1/2	#1/8-27	1-1/4	5/8	3/8	#10-24	3/8	.625	1.230	1/2	1/4	2.0	#5/16-18	1/2
	PBG202 x 3/4	#1/8-27	1-1/4	5/8	3/8	#10-24	3/8	.625	1.230	1/2	1/4	2.0	#5/16-18	1/2

* 1/8-27 Pipe Tap, Optional

** For magnetic piston, specify suffix "A". Refer to page 17 for track locations or see our Comtronic™ Limit Sensor catalog for additional sensor information.

NOTES:	
#1	Positive alignment mounting available on "B" Style Grippers. Consult factory.
#2	See page 16 for adjustable Jaw movement option.
#3	See page 15 for stock jaws.
#4	Gripping forces and unit weights on page 12.

FINGER OPTIONS — Finger Inserts below can be mounted to Master Jaws on gripper using 1 screw. By turning and positioning, each finger can be attached in numerous variations.

“L” SHAPED FINGER OPTION “LF”

TOOLING ONLY

To order a "set" of jaws only:

Specify: F 112 PLF

Series required

See below to order attached to gripper

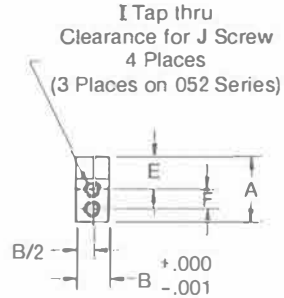
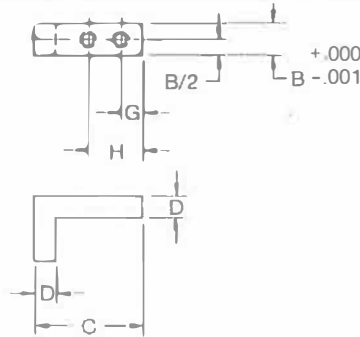

Gripper Series	Bore (Ref.)	A	B	C	D	E	F	G	H	I	J
052	1/2"	1/2	.249	1.0	1/8	1/4	0	3/16	1/2	#8-32	#4
072	3/4"	3/4	.374	1-1/4	1/4	3/8	7/32	1/4	5/8	#10-24	#6
112	1-1/8"	1.0	.499	1-1/4	1/4	1/2	9/32	1/4	5/8	#10-24	#6
132	1-3/8"										
162	1-5/8"	1-1/4	.624	1-1/2	3/8	5/8	11/32	1/4	11/16	#1/4-20	#10
202	2"										

NOTES:

- #1** Several mounting options for different open and closed positions.
- #2** Fingers made of "1018" Steel
- #3** Mounting screws are provided

ORDERING INSTRUCTIONS

STYLE	
DESCRIPTION	CODE
Parallel Square Barrel (End Mount) Gripper	PSG
Parallel Square Barrel (Side Mount) Gripper	PBG

JAW TRAVEL	CODE
1/8"	18
1/4"	14
1/2"	12
3/4"	34

OPTIONS	
DESCRIPTION	CODE
Adjustment Closed	ADJC
Adjustment Open	ADJO
Other options available refer to catalog COMPACT	

A
MAGNETIC PISTON
(OPTIONAL)

PBG
STYLE

072
BORE

12
JAW TRAVEL

LF
JAW STYLE
(OPTIONAL)

ADJC
(OPTIONAL)

MAGNETIC PISTON	
DESCRIPTION	CODE
Magnetic piston Cylinder and sensor mounting rail	A

BORE	CODE
1/2"	052
3/4"	072
1-1/8"	112
1-3/8"	132
1-5/8"	162
2"	202

JAW OPTION	
DESCRIPTION	CODE
L Shape jaw	LF

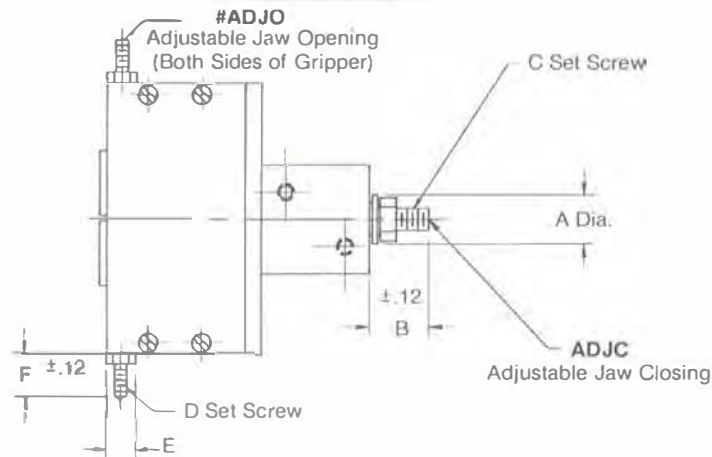
ADJUSTABLE JAW TRAVEL — PARALLEL GRIPPERS
OPTION “ADJO” / “ADJC”

Bore	Gripper Series	A	B	C	D	E	F
1/2	PG052 x 1/8	15/32	3/8	#10-32	#4-40	.29	5/16
	PG052 x 1/4	15/32	1/2	#10-32	#4-40	.29	7/16
3/4	PG072 x 1/4	9/16	11/16	1/4-20	6-32	.36	7/16
	PG072 x 1/2	9/16	15/16	1/4-20	6-32	.36	11/16
1-1/8	PG112 x 1/4	3/4	13/16	3/8-16	8-32	.36	7/16
	PG112 x 1/2	3/4	1-1/16	3/8-16	8-32	.36	11/16
1-3/8	PG132 x 1/2	3/4	1-1/16	3/8-16	10-24	.43	3/4
	PG132 x 3/4	3/4	1-5/16	3/8-16	10-24	.43	1
1-5/8	PG162 x 1/2	3/4	1-1/16	3/8-16	10-24	.43	3/4
	PG162 x 3/4	3/4	1-5/16	3/8-16	10-24	.43	1
2	PG202 x 1/2	1	1-1/4	1/2-13	10-24	.43	3/4
	PG202 x 3/4	1	1-1/2	1/2-13	10-24	.43	1

NOTES:

- #1** ADJC consists of Set Screw, Locking Nut, and Thread Seal.
- #2** ADJO consists of 2 Set Screws and 2 Locking Nuts.
- #3** “PA” option not available on ADJC option.

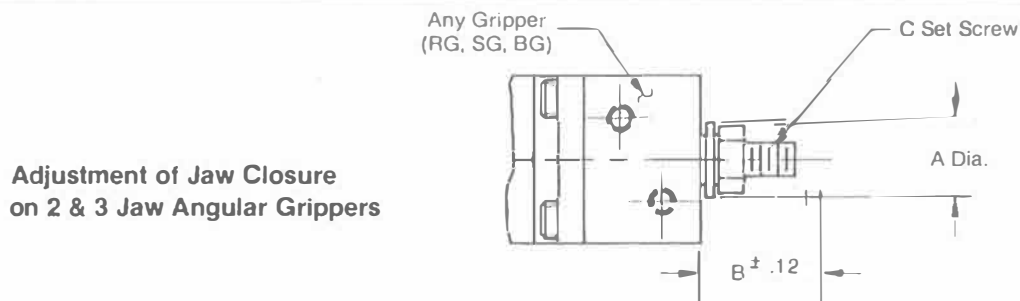
ADJUSTABLE JAW TRAVEL — ANGULAR GRIPPERS
OPTION ADJC (Closed Adjustment Only)

SERIES	052	072/073	112/113	162/163	202	252/253	302/303	402/412/403	502/503	602/603	802/803
BORE	1/2	3/4	1-1/8	1-5/8	2	2-1/2	3	4	5	6	8
A	15/32	9/16	3/4	3/4	1	1	1-3/8	1-3/8	1-3/8	1-3/8	1-3/8
B	3/8	9/16	11/16	11/16	15/16	15/16	1-1/4	1-3/8	1-3/8	1-1/2	1-3/4
C	10-32	1/4-28	3/8-24	3/8-24	1/2-13	1/2-13	3/4-10	3/4-10	3/4-10	3/4-10	3/4-10



Dimensions Typical for RG, SG, & BG style angular grippers.

NOTES:

- #1** Adjustment consists of Set Screw, Locking Nut, and Thread Seal.
- #2** Adjustment for Jaw closing only.
- #3** “PA” option not available with ADJC option.

— Sensor Track Locations for Magnetic Piston Grippers —

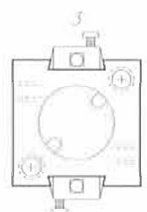
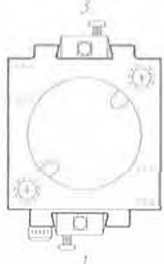
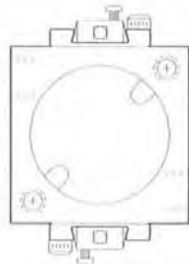
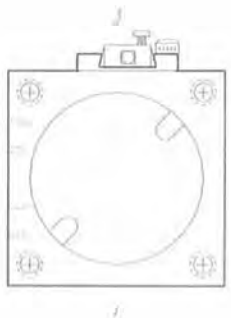
Diagrams illustrate rear of gripper actuator

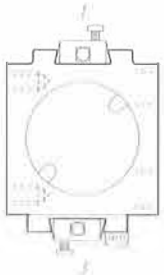
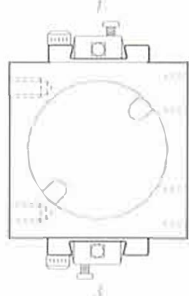
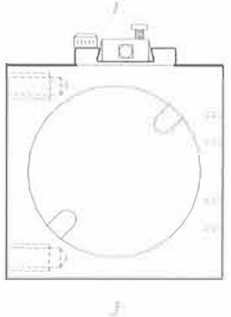
	1/2"	3/4"	1-1/8"	1-3/8" -1-5/8"	2" & UP
Style "S" End Mount	Design accommodates one sensor only 			<ul style="list-style-type: none"> Parallel grippers with 3/4" jaw travel have one sensor mounting track  <ul style="list-style-type: none"> Omit track on side 1 	
Style "B" Base Mount				 <ul style="list-style-type: none"> Omit track on side 3 	

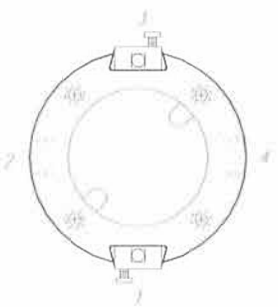
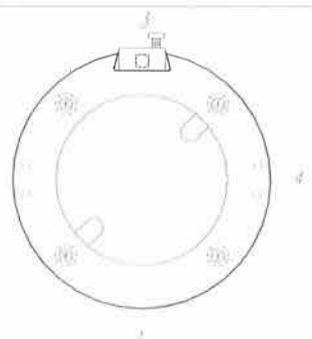
	3/4" - 1-5/8"	2" & UP
Style "R" End Mount		

Dimensional Information

Angular Gripper

1/2" - Pre-calculated on dimensional page
3/4" thru 8" - Suffix "A" adds 1/4" to the overall actuator length

Parallel Gripper

Pre-calculated on dimensional page

NOTE: The magnetic option is designed for sensing jaws "fully open" and "fully closed" only, not for indication of part. Reliable limit sensing may be adversely affected by minimal stroke grippers when sensing both open and close positions.

See our Comtronic® Limit Sensor catalog for additional sensor information



SECTION

C

OPTIONS AND ACCESSORIES

COM-PICK COM-PICK II

2 & 3 JAW PNEUMATIC GRIPPERS

ACTUATOR SEAL OPTIONS

FOR ALL COMPACT AIR GRIPPERS Angular & Parallel

SEAL TYPE	STANDARD	OPTION	CODE	(PSI) PRESSURE	° F. TEMPERATURE RANGE
BUNA-N	*		—	2-200 PSI	0° F. to 200° F.
**Hi Temp. Viton		*	HTV	10-200 PSI	0° F. to 400° F.
**Hi Temp. "TFE"		*	HTT*	10-200 PSI	+200° F. to +500° F.

**Due to metal expansion in elevated temperatures, our Jaw fit may have to be re-ground to compensate.

Consult factory regarding other seal compounds or applications using media other than compressed air.

*Not available on 1/2" Bore Models.

SECTION

D

APPLICATION IDEAS

FOR ENGINEERING OR TECHNICAL ASSISTANCE

Call: 864-647-9568 Fax: 864-647-9574

SPECIALS WELCOME!



Typical Modifications to Blank Jaws



Special Tooling Modifications

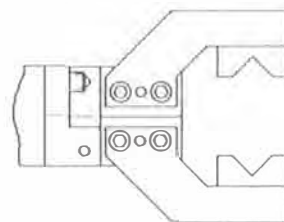

Bolt-on tooling

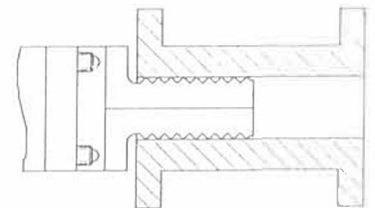

- I.D. Gripping**
- Textile applications
 - Bulk wire handling

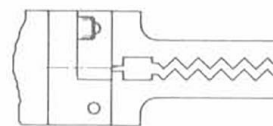

- "Spru-pickers" for Plastic Molds**
- Serrated and carbide jaws

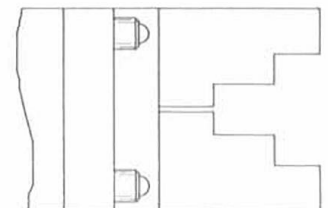

- Stepped Jaws**
- Benchtop workholding
 - Multi-sized parts handling

TABLE OF CONTENTS

<p><i>Introduction to Collet Workholding</i> 2</p> <p><i>Square Body Collet Closers</i> 3</p> <p><i>Precision Square Body Collet Closers</i> 3</p>	<p><i>SC Series 1C Closer</i> 4</p> <p><i>SC Series 3C Closer</i> 5</p> <p><i>SC Series 5C Closer</i> 6</p> <p><i>PSC Series 5C Closer</i> 7</p> <p><i>Collet Options</i> 8</p>	<p><i>Collet Information</i> 9</p> <p><i>Collet Position Sensors</i> 10</p> <p><i>Intensifiers</i> 11</p> <p><i>Additional Information</i> 12</p>
--	---	---



Introduction to Collet Workholding

Collet workholding has been around a long time. Collets are used worldwide in the metalworking industry for their high accuracy and high output gripping of tools and work pieces.

Compact Air Products has chosen 3 popular collet sizes: 1C, 3C, and 5C, to design our space efficient collet fixtures around. Two designs are offered: **SC** series and **PSC** series, powered by pneumatic or hydraulic

pressure up to 1000 psi. Output gripping forces range from several pounds through 4-1/2 tons.

Compact collet closers are offered in the space efficient, cost effective packages demanded by modern factory automation. They are ideal stationary fixtures for metalworking, bench top assembly, precision robotics and assembly machine applications. Other applications include crimping, forming and staking.

Collet Sizes / Capacities

1C, 3C, and 5C represent an international standard for collet sizes. 1C is miniature, 3C twice the capacity of 1C, and 5C more than twice the capacity of the 3C. See page 8 for details on collet capacities. (Larger collet closers are also available on special order.)

The collet closers detailed in this catalog do not include a collet. Collets are sold separately. Compact Air Products sells *only* American made collets.

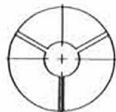

Round

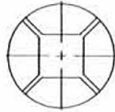

Square

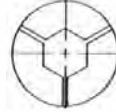

Hexagon

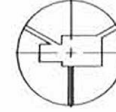

Special

Collet Closers - Stationary Fixture Types - SC and PSC Series



Precision heavy duty
5C model - PSC305C



Standard grade
5C model - SC305c



Miniature size
3C model - SC163C



Miniature size
1C model - SC111C

Our 4 models are available *off the shelf!*
Special mounting holes, port locations and mounting hardware can be quoted upon request.

- **Hardened wear surfaces**
- Many mounting options
- Pilots on 3 surfaces

- Optional position sensors
- **Air or hydraulic service up to 750 PSI**
- Low weight aluminum housing

- Hollow rear surface
- Brass tip collet lock screw
- **Available from stock**



SC Series - Square Body Collet Closers

The SC series is offered in 3 collet sizes: 1C, 3C, and 5C. It is our most cost effective and versatile series. It is what we call a "constant height collet" design. The collet is threaded into a stationary base inside our closer. The piston is driven upward with pressure and closes the collet. Pressure in the opposite direction allows the collet to open.

The SC series closers are ideal for bench top workholding, light machining and grinding fixtures, crimping devices, wire feeding devices, precision robotic end effectors, tool holders, and many other stationary (non-spinning) workholding applications. Under no side load, repeatability is within .0005" TIR. Under maximum side load the repeatability is within .003" TIR.

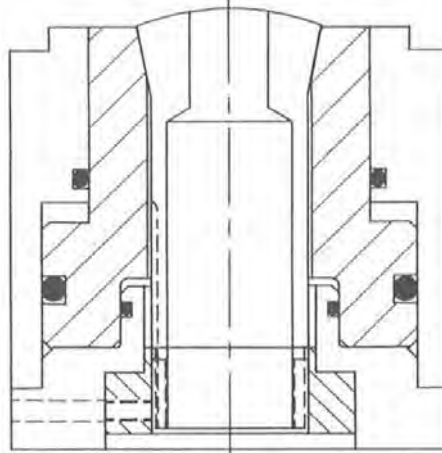

Options include collet position sensors: see page 10, also available: adjustable work piece stops. Complete closer, collet, pressure booster, and control packages, see page 11.

PSC Series - Precision Tolerance/Square Body Collet Closers

The PSC series closers are 5C collet size *only* and are designed specifically for high accuracy workholding under high loads found in typical metalworking fixtures. It is what we call a "collet puller" design. The 5C collet is threaded into the piston and is pulled against a rigid surface plate when the piston is retracted with pressure. Pressure in the opposite direction allows the collet to open.

The PSC series closers are rugged yet space and weight efficient for stationary fixtures for many metalworking and other heavy duty work-

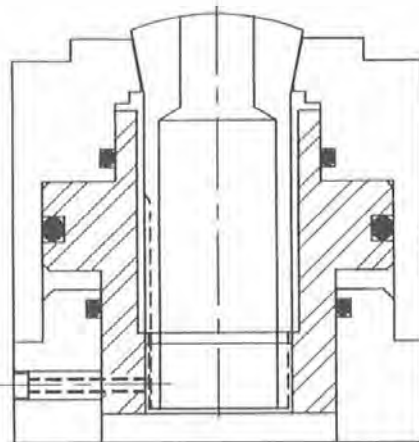

holding applications; drilling and tapping machines, milling machines, surface grinding machines, etc . . . that require high accuracy of .001" TIR under maximum side load.

Options include a heavy duty collet position sensor: see page 10, also available: precision mounting flange and adjustable work piece stops. For complete closer, collet, pressure booster and control packages, see page 11.

APPLICATION EXAMPLES

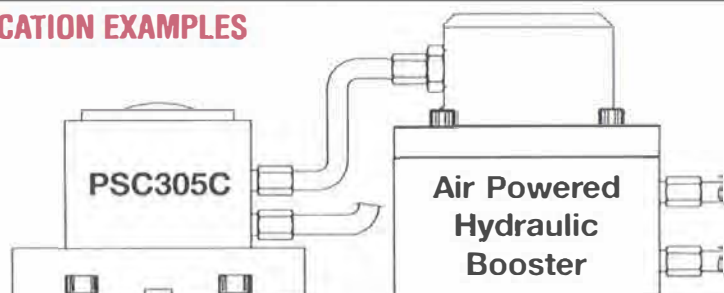
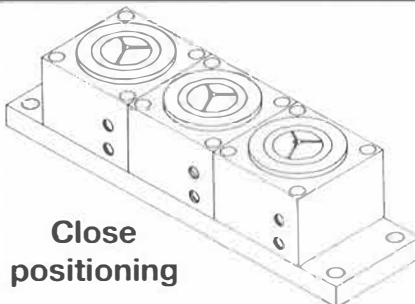



SC series

Model # SC111C

SC - Square body collet closer 11 - 1.12" Diameter piston 1C - Miniature 1C - Collet ready

• Collets sold separately page 8 • Positive Stop Option page 8 • Position Sensor page 10

Specifications

Input Pressure (PSI)	Pneumatic = 250 Hydraulic = 750
Maximum Work Holding Force in Pounds (lbs)	Pneumatic = 337 Hydraulic = 1,062
Minimum Input Pressure	25 PSI
Maximum Diameter with Thru Collet With Step Collet	1/4" Not Available
Volume Displacement of Actuator	Collet Open = .08 in ³ Collet Closed = .09 in ³
Control Circuit	4-way valve, Double acting
Grease Port	Not Available
Standard Seals - Buna N	0° to 200°F (-15 to 120°C)
Unit Weight without Collet	6 ounces

Repeatability (TIR)

Zero side load = .0005" Maximum side load = .003"

Seal Options - High temperature Viton hydraulic

Ordering Suffix: VHYD 0° to 400°F (200°C)

Theoretical Clamping Force

Gripping Force (lbs) = (Input pressure x 1.45) - 25.6*
Example (100psi x 1.45) - 25.6 = 119.40 lbs

Pull out Force (lbs) = Gripping Force x μ
Example 119.4 lbs x .35 = 41.79 lbs
μ = evaluation between the collet and workpiece

Gripping Torque (in-lbs) = Pull out Force x D x .5
Example 41.79 x .25 x .5 = 5.22 inch-lbs
D = diameter (in) of the workpiece

Theoretical clamping force calculations are based on ideal situations. Supply pressure fluctuations, collet conditions, and surface lubricants will alter workpiece holding values. For maximum collet closer efficiency, the interface between the collet closer and the collet should be clean, smooth, and lubricated. For maximum work holding efficiency, the interface between the collet and the workpiece should be clean and dry.

Definitions:

Gripping Force (lb): Force collet jaws apply to the workpiece

Pull out Force (lb): Force required to pull the workpiece from the collet

Gripping Torque (in-lbs): Torque required to twist workpiece in the collet

Coefficient of Friction (μ): The relationship of friction and force between surfaces

*Number of pounds required to close the collet

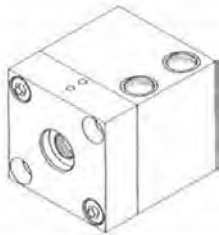

Hollow Rear Surface

Collets shown for reference only (sold separately) -- see page 8

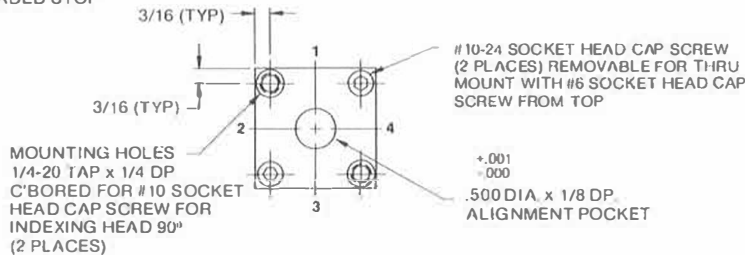
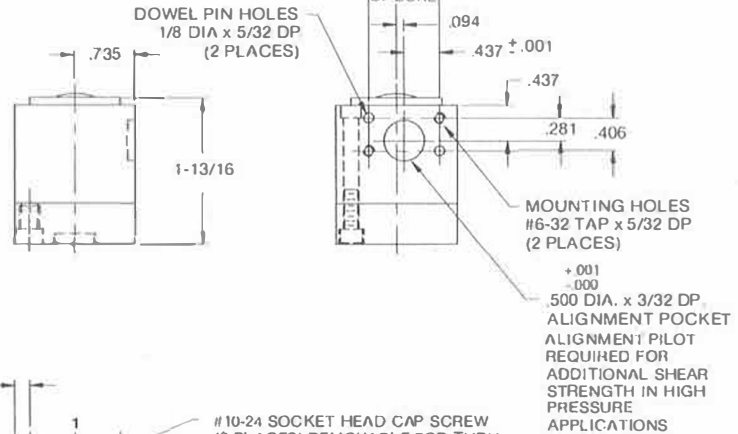
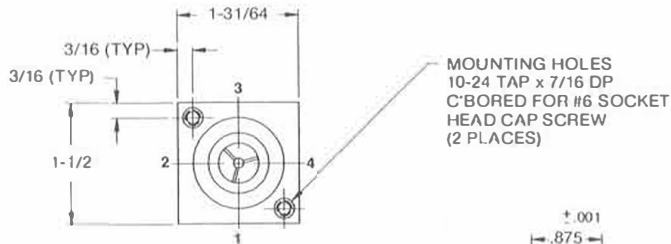
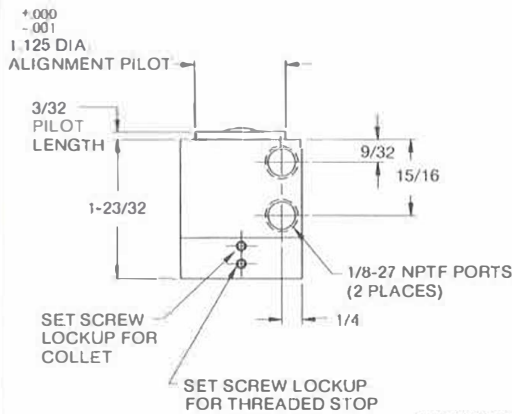



SC series

Model # SC163C

SC - Square body collet closer 16 - 1.62" Diameter piston

3C - 3C Collet ready

• Collets sold separately page 8 • Positive Stop Option page 8 • Position Sensor page 10

Specifications

Input Pressure (PSI)	Pneumatic = 250 Hydraulic = 750
Maximum Work Holding Force in Pounds (lbs)	Pneumatic = 712 Hydraulic = 2,258
Minimum Input Pressure	25 PSI
Maximum Diameter with Thru Collet With Step Collet	1/2" 5/8"
Volume Displacement of Actuator	Collet Open = .12 in ³ Collet Closed = .19 in ³
Control Circuit	4-way valve, Double acting
Grease Port	Standard
Standard Seals - Buna N	0° to 200°F (-15° to 120°C)
Unit Weight without Collet	1 lb. 1 oz.

Theoretical Clamping Force

Gripping Force (lbs) = (Input pressure x 3.09) - 60 *
Example (100psi x 3.09) - 60 = 249.00 lbs

Pull out Force (lbs) = Gripping Force x μ
Example 249 lbs x .35 = 87.15 lbs
 μ = evaluation between the collet and workpiece

Gripping Torque (in-lbs) = Pull out Force x D x .5
Example 87.15 x .5 x .5 = 21.79 inch-lbs
D = diameter (in) of the workpiece

Theoretical clamping force calculations are based on ideal situations. Supply pressure fluctuations, collet conditions, and surface lubricants will alter workpiece holding values. For maximum collet closer efficiency, the interface between the collet closer and the collet should be clean, smooth, and lubricated. For maximum work holding efficiency, the interface between the collet and the workpiece should be clean and dry.

Definitions:

Gripping Force (lb): Force collet jaws apply to the workpiece
Pull out Force (lb): Force required to pull the workpiece from the collet
Gripping Torque (in-lbs): Torque required to twist workpiece in the collet
Coefficient of Friction (μ): The relationship of friction and force between surfaces

*Number of pounds required to close the collet

Repeatability (TIR)

Zero side load = .0005" Maximum side load = .003"

Seal Options - High temperature Viton hydraulic
Ordering Suffix: VHYD 0° to 400°F (200°C)

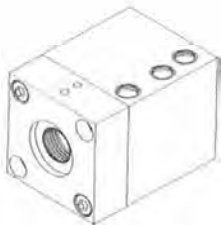

Hollow Rear Surface

Collets shown for reference only (sold separately) - see page 8

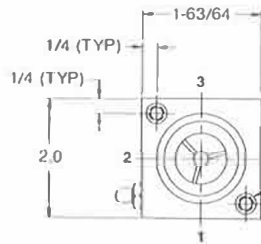

MOUNTING HOLES
1/4-20 TAP x 5/8 DP
C'BORED FOR #10
SOCKET HEAD CAP SCREW
(2 PLACES)

+ .000
- .001
1.500 DIA.
ALIGNMENT PILOT

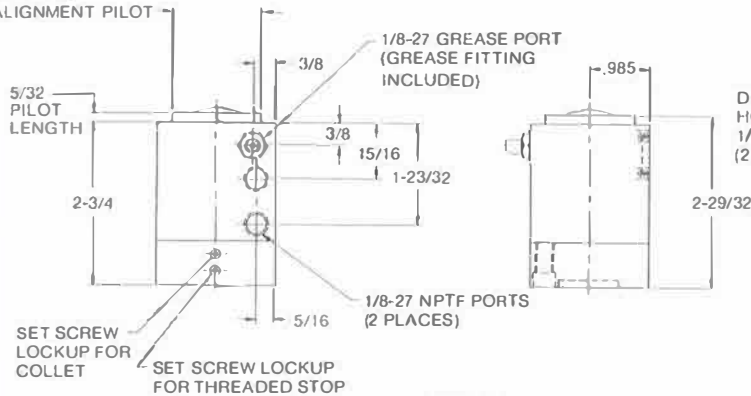

DOWEL PIN HOLES
1/8 DIA. x 9/32 DP
(2 PLACES)

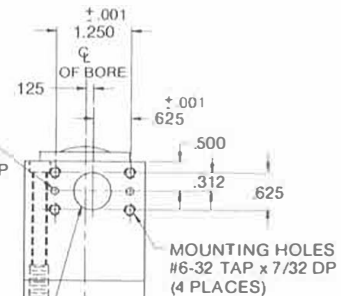

+ .001
- .000
625 DIA. x 1/8 DP
ALIGNMENT POCKET
ALIGNMENT PILOT REQUIRED FOR ADDITIONAL SHEAR STRENGTH IN HIGH PRESSURE APPLICATIONS

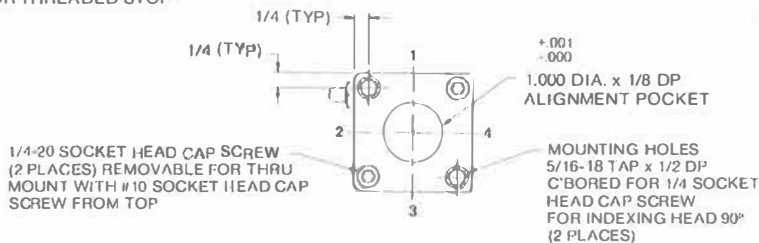



SC series

Model # SC305C

SC - Square body collet closer

30 - 3.0" Diameter piston

5C - 5C collet ready

• Collets sold separately page 8 • Positive Stop Option page 8 • Position Sensor page 10

Specifications

Input Pressure (PSI)	Pneumatic = 250 Hydraulic = 750
Maximum Work Holding Force in Pounds (lbs)	Pneumatic = 2,815 Hydraulic = 8,965
Minimum Input Pressure	25 PSI
Maximum Diameter with Thru Collet With Step Collet	1-1/16" 6"
Volume Displacement of Actuator	Collet Open = .48 in ³ Collet Closed = .72 in ³
Control Circuit	4-way valve, Double acting
Grease Port	Standard
Standard Seals - Buna N	0° to 200°F (-15° to 120°C)
Unit Weight without Collet	3 lbs. 12 oz.

Repeatability (TIR)

Zero side load = .0005" Maximum side load = .003"

Seal Options - High temperature Viton hydraulic

Ordering Suffix: VHYD 0° to 400°F (200°C)

Theoretical Clamping Force

Gripping Force (lbs) = (Input pressure x 12.3) - 260"
Example (100psi x 12.3) - 260 = 970.00 lbs

Pull out Force (lbs) = Gripping Force x μ
Example 970 lbs x .35 = 339.50 lbs
 μ = evaluation between the collet and workpiece

Gripping Torque (in-lbs) = Pull out Force x D x .5
Example 339.5 x 1.0625 x .5 = 180.36 inch-lbs
D = diameter (in) of the workpiece

Theoretical clamping force calculations are based on ideal situations. Supply pressure fluctuations, collet conditions, and surface lubricants will alter workpiece holding values. For maximum collet closer efficiency, the interface between the collet closer and the collet should be clean, smooth, and lubricated. For maximum work holding efficiency, the interface between the collet and the workpiece should be clean and dry.

Definitions:

Gripping Force (lb): Force collet jaws apply to the workpiece

Pull out Force (lb): Force required to pull the workpiece from the collet

Gripping Torque (in-lbs): Torque required to twist workpiece in the collet

Coefficient of Friction (μ): The relationship of friction and force between surfaces

*Number of pounds required to close the collet

Collets shown for reference only (sold separately) – see page 8



Hollow Rear Surface

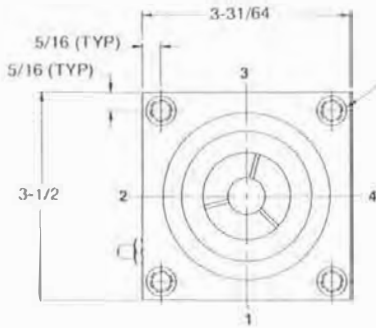

MOUNTING HOLES
3/8-16 TAP x 15/16 DP
C'BORED FOR 5/16 SOCKET
HEAD CAP SCREW
(4 PLACES)

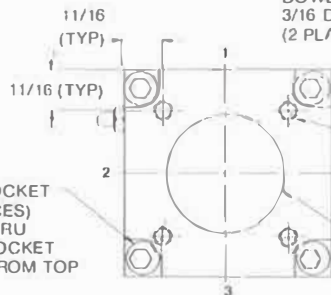
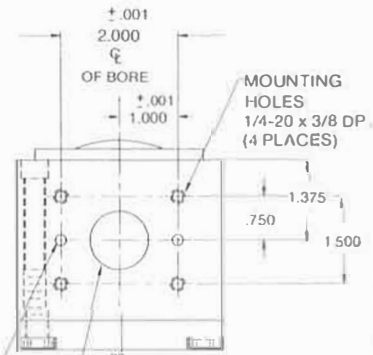
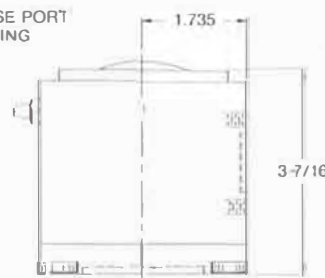
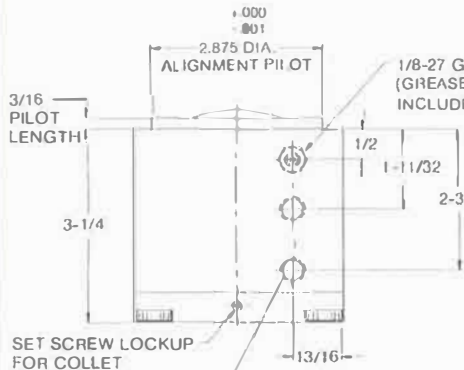

MOUNTING HOLES
5/16-18 TAP x 1/4 DP
(4 PLACES)

2.000 DIA. x 1/8 DP
ALIGNMENT POCKET



PSC series

Model # PSC305C

PSC - Square body collet closer

30 - 3.0" Diameter piston

5C - 5C collet ready

• Collets sold separately *page 8* • Positive Stop Option *page 8* • Position Sensor *page 10*

Specifications

Input Pressure (PSI)	Pneumatic = 250 Hydraulic = 1000
Maximum Work Holding Force in Pounds (lbs)	Pneumatic = 2,815 Hydraulic = 12,040
Minimum Input Pressure	25 PSI
Maximum Diameter with Thru Collet With Step Collet	1-1/16" 6"
Volume Displacement of Actuator	Collet Open = .61 in ³ Collet Closed = .72 in ³
Control Circuit	4-way valve, Double acting
Grease Port	Not Available
Standard Seals - Buna N	0° to 200°F (-15° to 120°C)
Unit Weight without Collet with Flange (PRF)	4 lbs, 14.5 oz. <i>plus 8.5 oz.</i>

Repeatability (TIR)

Zero side load = .0005" Maximum side load = .001"

Seal Options - High temperature Viton hydraulic

Ordering Suffix: VHVD 0° to 400°F (200°C)

Theoretical Clamping Force

Gripping Force (lbs) = (Input pressure x 12.3) - 260*
Example (100psi x 12.3) - 260 = 970.00 lbs

Pull out Force (lbs) = Gripping Force x μ
Example 970 lbs x .35 = 339.50 lbs
μ = evaluation between the collet and workpiece

Gripping Torque (in-lbs) = Pull out Force x D x .5
Example 339.5 x 1.0625 x .5 = 180.36 inch-lbs
D = diameter (in) of the workpiece

Theoretical clamping force calculations are based on ideal situations. Supply pressure fluctuations, collet conditions, and surface lubricants will alter workpiece holding values. For maximum collet closer efficiency, the interface between the collet closer and the collet should be clean, smooth, and lubricated. For maximum work holding efficiency, the interface between the collet and the workpiece should be clean and dry.

Definitions:

Gripping Force (lb): Force collet jaws apply to the workpiece

Pull out Force (lb): Force required to pull the workpiece from the collet

Gripping Torque (in-lbs): Torque required to twist workpiece in the collet

Coefficient of Friction (μ): The relationship of friction and force between surfaces

*Number of pounds required to close the collet

Collets shown for reference only (sold separately) – see page 8

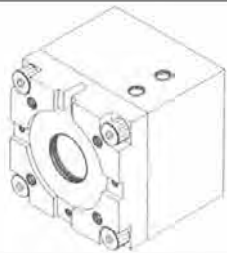

Hollow Rear Surface

HIDDEN LINES SHOW OPTIONAL MOUNTING FLANGE PART #PRF

MOUNTING HOLES 3/8-16 TAP x 15/16 DP C'BORED FOR 5/16 SOCKET HEAD CAP SCREW (4 PLACES)

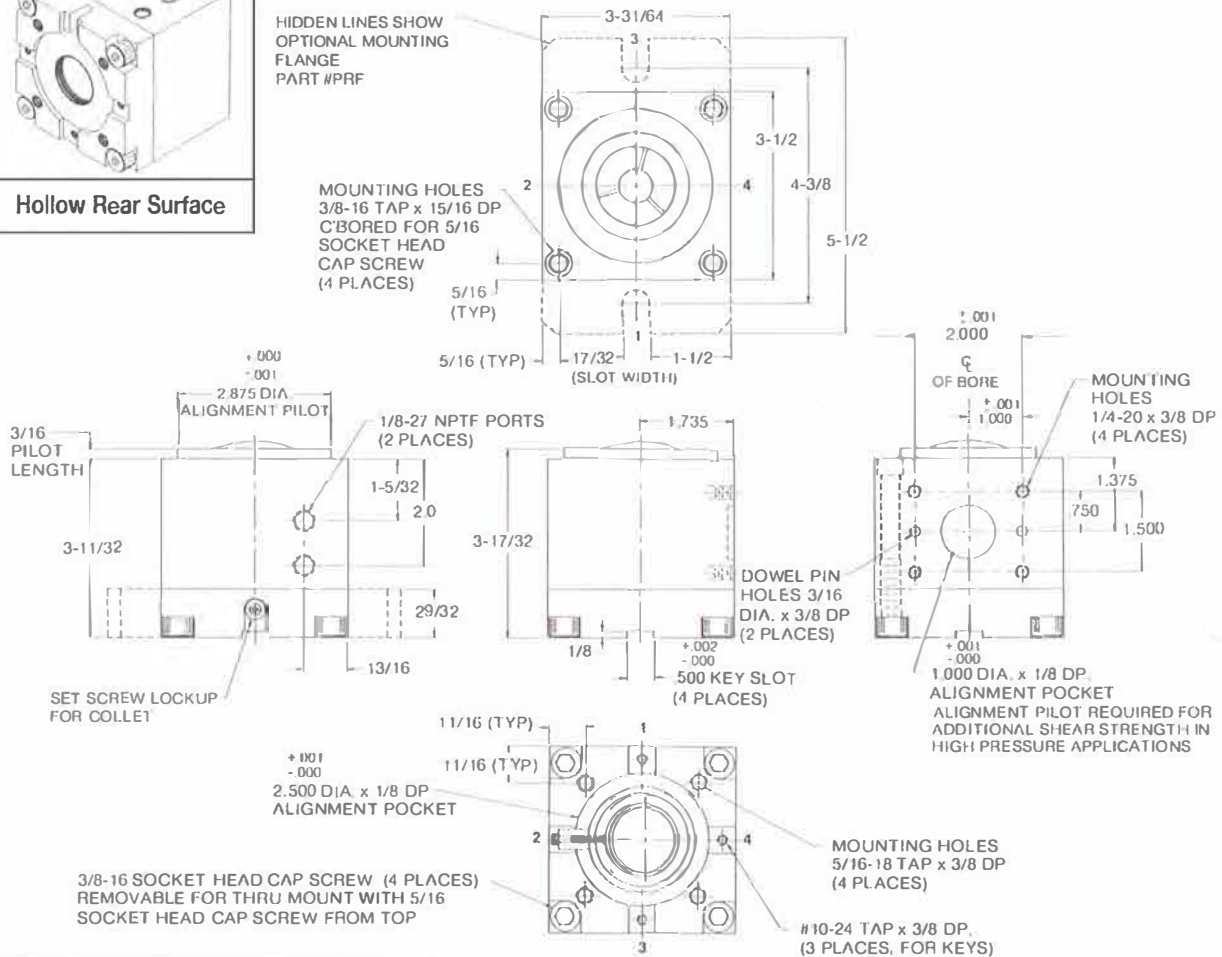

SEE OUR AIR POWERED OIL INTENSIFIERS SEE PAGE 11 AND BULLETIN INTENSIFIERS 92

(Low cost hydraulic power)



Collet Capacities Reference Only



Consult the factory for collet suppliers
Collets sold separately - not installed into the closer.

COLLET SIZE	ROUND HOLES	HEXAGON HOLES	SQUARE HOLES
1C	 1/64" Minimum 1/4" Maximum 1/64" Increments	 1/64" Minimum 7/32" Maximum 1/64" Increments	 1/64" Minimum 11/64" Maximum 1/64" Increments
	Standard stock		Special order

COLLET SIZE	ROUND HOLES	HEXAGON HOLES	SQUARE HOLES
3C	 1/64" Minimum 1/2" Maximum 1/64" Increments	 3/32" Minimum 7/16" Maximum 1/32" Increments	 3/32" Minimum 11/32" Maximum 1/32" Increments
	Standard stock		Standard stock

3C Emergency Collets These are steel 3C collets without a finished hole. Ideal for special sizes and shapes, or to have in stock for emergencies.

COLLET SIZE	ROUND HOLES	ROUND HOLES BY DECIMAL	ROUND HOLES IN METRIC
5C	 1/64" Minimum 1-1/16" Maximum 1/64" Increments	 .016 Minimum 1.030 Maximum .001 Increments	 .5 mm Minimum 27 mm Maximum .5mm Increments
	Standard stock		Standard stock

COLLET SIZE	RECTANGULAR HOLES	HEXAGON HOLES	SQUARE HOLES
5C	 1/8 x 5/32 Minimum 5/8 x 3/4 Maximum Inclusive	 1/16" Minimum 7/8" Maximum 1/64" Increments	 3/64" Minimum 3/4" Maximum 1/64" Increments
	Special order		Special order

5C Emergency Collets These are steel or bronze 5C collets without a finished hole. Ideal for special sizes or shapes, or to have in stock for emergencies.

Positive Work Piece Stops

Specify "WS"

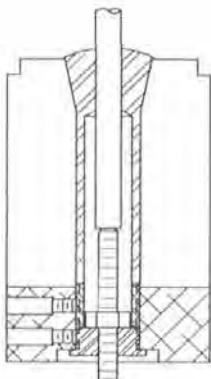

Since the miniature collets do not have ID threads, we supply a thread behind the collet to install a work piece stop.

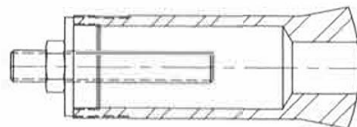
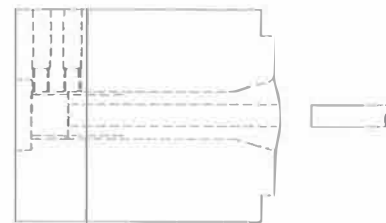

5C collet sizes under 1-1/16 have ID threads, the work piece stop is installed directly into the collet, then this assembly is installed into the collet closer.



Special 5C Collets

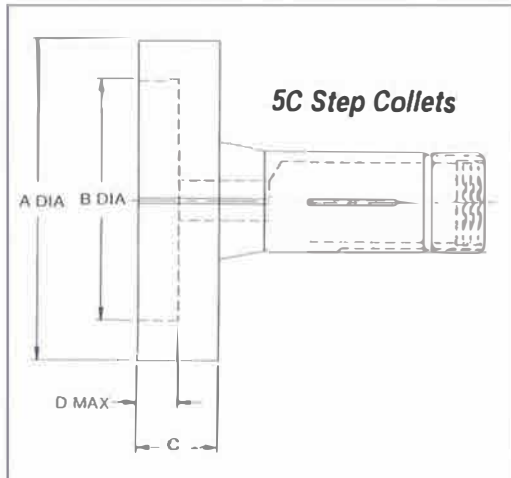

MODEL	A	B	C	D
5C-2"	2"	1-3/4"	1"	1/2"
5C-3"	3"	2-1/2"	1"	1/2"
5C-4"	4"	3"	1"	1/2"
5C-6"	6"	5"	1"	1/2"

Special Order - Consult Factory



- ☆ Step collets are also called step chucks, but remember, our collet fixtures are for stationary use only (**NOT** spinning).
- ☆ Extended nose collets provide creative workholding possibilities by extending the gripping force out from the face of the closer. There are limits to be considered, consult factory for application assistance
- ☆ Expanding collets: Consult factory.

Cross Section of Standard 1C, 3C and 5C Collets

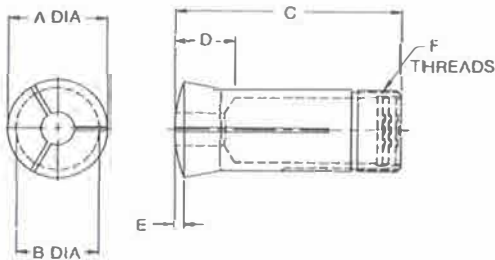

COLLET	A	B	C	D	E	F
1C	1/2	.335	1-31/64	13/32	3/64	.330-40
3C	55/64	.650	2-25/32	11/16	3/32	.651-26
5C	1-15/32	1-1/4	3-27/64	15/16	9/64	1.253-20

All collets are made of hardened steel except for 5C emergency bronze type

Installing Collet into Closer

Simply thread collet into closer and then secure the set screw locker. For high load applications, it is *important* to lock the collet using the keyway. The keyway is standard on all collets.

NOTE: Height can not be exactly determined until the collet is installed and can vary by turning the collet in or out of the threaded connection.

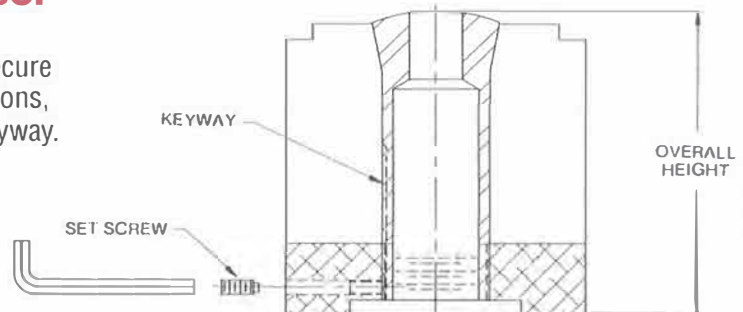

ALLEN KEY	
SC1C	.050" hex
SC3C & SC5C	5/64" hex
PSC-5C	3/32" hex

Feature: A brass tipped dog point set screw is included in each closer.



Collet Position Sensors

Senses Magnetic Piston in Collet Closer/Non-contact Sensor

- 5-30 VDC solid state sensor
- Magnetic piston is required in actuator, does not change envelope dimensions.
- Collet open or collet close signals (only one can be sensed, your choice at installation)
- LED indicator

• See our Comtronic® limit sensor catalog for more specific data on sensors

- Compact envelope
- Sinking or Sourcing outputs
- Collets must be adjusted by user to allow for 1/16" minimum stroke travel.



Option "A" – Magnetic Piston and Sensor Mounting Rail

Add prefix "A" to standard part number

Examples: ASC111C / ASC163C / ASC305C / APSC305C

Notes: 1) All sensor mounting rails are located on side labeled (1), 90° from ports, refer to dimensional pages

2) Option "A" includes an internal magnetic piston and a sensor mounting rail. **Sensors sold separately.**

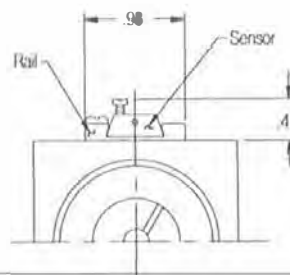

See our Comtronic® Limit Sensor catalog for additional sensor information



Pilot Options

DUAL DIAMETER

Part No.	A	B	C	D
PL118-05	.4997	.249	11/64	3/32
PL118-07	.4997	.312	3/16	7/64
PL158-07	.6247	.312	3/16	7/64
PL158-11	.6247	.499	3/16	7/64

Part No.	A	B	C	D
PL3-11	.9997	.499	3/16	7/64
PL3-16	.9997	.624	1/4	11/64
PL3-20	.9997	.749	5/16	15/64

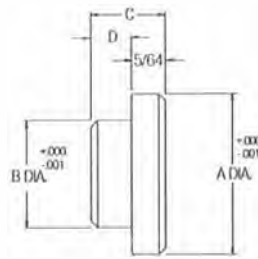

COMMON DIAMETER

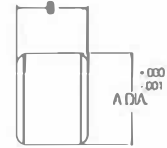

Part No.	A	B
PL118L	.4997	13/64
PL158L	.6247	19/64

Rear Mounting Flange Specify: "RF" (200 PSI PNEUMATIC ONLY)

Mounting pattern for SC11 & SC16

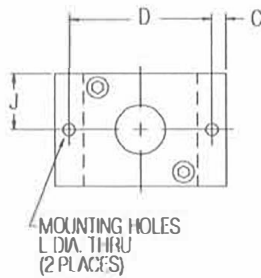

Mounting pattern for SC30

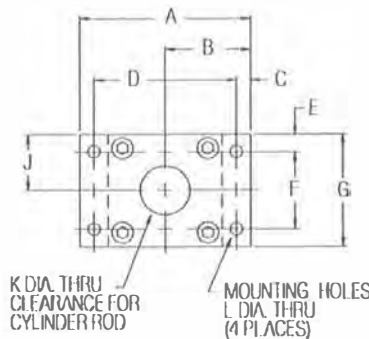

SIZE	A	B	C	D	E	F	G	H	J	K	L
SC11	3"	1-1/2"	1/4"	2-1/2"	-	-	2"	1/4"	1"	3/4"	7/32"
SC16	2-1/2"	1-1/4"	1/4"	2"	1/4"	2"	2-1/2"	1/4"	1-1/4"	1-1/8"	7/32"
SC30	4"	2"	5/16"	3-3/8"	5/16"	3-3/8"	4"	3/8"	2"	2-1/8"	11/32"

Air Powered Oil Intensifiers

"SHOP AIR IN — GETS HIGH PRESSURE OIL OUT"

"GANG MOUNTED" COLLET CLOSERS

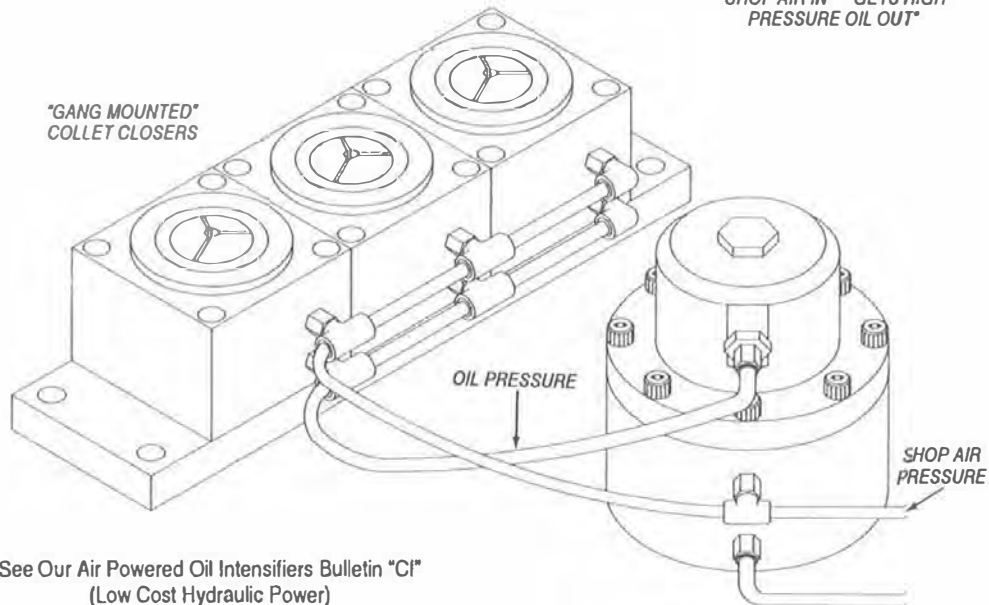

See Our Air Powered Oil Intensifiers Bulletin "CI"
(Low Cost Hydraulic Power)

Compact Pneumatic 90° Twist Cylinders

INTRODUCTION

New compact pneumatic twist cylinders are linear motion compact cylinders with an internal cam that provides 90° swing motion. Twist cylinders are ideal swing clamps for automated and semi-automated assembly and workholding found in circuit board assemblies, medical devices, robotic cells, component

assembly and other applications. Because of their compact size and versatile mounting, they also make unique conveyor stops, diverters, escapements, etc. We will be glad to quote on special stroke and increments of rotation.

PRESSURE RATINGS - BAR			PISTON AREA mm ²	
Bore	Pneumatic	▲ Hydraulic	Push	Pull
12	8 (117 PSI)	Not Available	113 (.17 in ²)	85 (.13 in ²)
25	8 (117 PSI)		490 (.76 in ²)	376 (.58 in ²)
40	8 (117 PSI)		1256 (1.9 in ²)	1055 (1.6 in ²)

▲ Non-shock service with hydraulic seal option

UNIQUE UNIVERSAL CAM DESIGN

All units feature our unique universal cam. Specify unit to be assembled as TC(L) or (R) as explained below. Universal feature: remove the cam pin, rotate cam and reassemble to convert the twist motion.

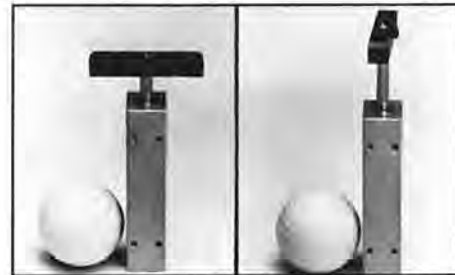

Shown in First Angle Projection

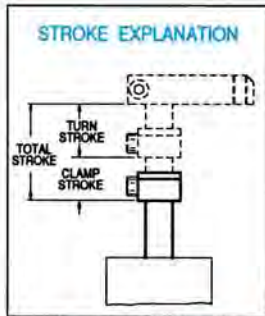
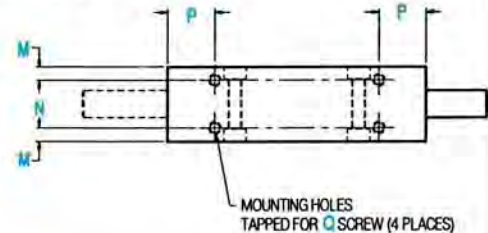
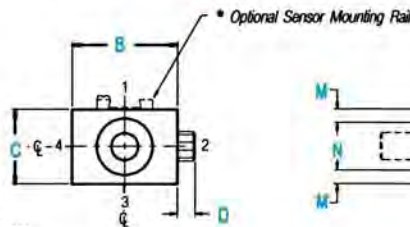
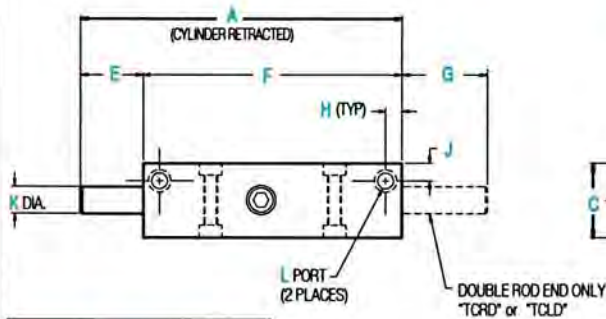
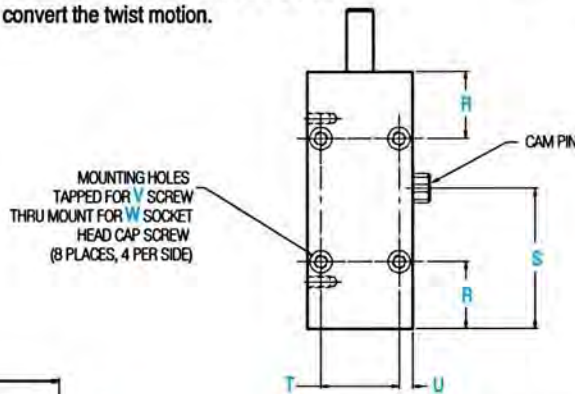
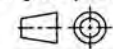

IMPORTANT: Never attempt to clamp a part during the "turn stroke" of the cycle. This will result in damage to the mechanism.

* Optional sensor rail with magnetic piston (Prefix "A") does not add any additional length. Comtronic™ sensors available #WSK #WSK-3 #WSC #WSC-3 (see #Metric catalog)

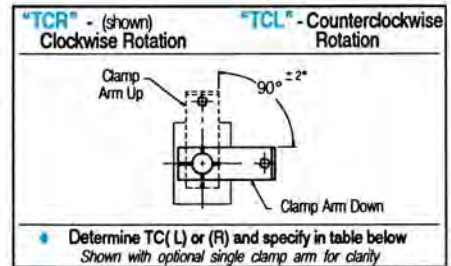

◆ Determine TC (L) or (R) and specify in table below
Shown with optional single clamp arm for clarity

Dimensions Shown In Parentheses () = Inch Conversions

BORE	♦ PART NUMBER	STROKE			A	B	C	D	E	F	G	H	J	K	L	M	N	P	Q	R	S	T	U	V	W
		TOTAL	TURN	CLAMP																					
12mm	TC_12x20	20	11	9	109	25,5	19	5	23	86	32,5	5,2	5	6	M5x0,8	3,5	12	15	M3x0,5	21	49,6	18	3,7	M4x0,7	M3x0,5
					(4,29)	(1,00)	(.75)	(.20)	(.91)	(3,39)	(1,28)	(.20)	(.20)	(.24)	(.14)	(.47)	(.59)	x 5,5	(.83)	(1,95)	(.71)	(.15)			
25mm	TC_25x30	30	22	8	143	47	33	6	38	105	46	7,3	8	12	G 1/8	6	21	21	M5x0,8	30	57,6	35	6	M6x1,0	M5x0,8
					(5,83)	(1,85)	(1,30)	(.24)	(1,50)	(4,13)	(1,81)	(.29)	(.31)	(.47)	(.24)	(.83)	(.83)	x 10	(1,18)	(2,27)	(1,38)	(.24)			
40mm	TC_40x30	30	22	8	153	47	33	6	38	115	51	7,3	8	12	G 1/8	6	21	21	M5x0,8	30	62,6	35	6	M6x1,0	M5x0,8
					(6,02)	(1,85)	(1,30)	(.24)	(1,50)	(4,53)	(2,01)	(.29)	(.31)	(.47)	(.24)	(.83)	(.83)	x 10	(1,18)	(2,46)	(1,38)	(.24)			
40mm	TC_40x35	35	22	13	149	65	49	6	38	111	54	10	24,5	16	G 1/8	6	37	25	M6x1,0	35	61	52	6,5	M6x1,0	M5x0,8
					(5,87)	(2,56)	(1,93)	(.24)	(1,50)	(4,37)	(2,13)	(.39)	(1,00)	(.63)	(.24)	(1,46)	(.98)	x 14	(1,38)	(2,40)	(2,05)	(.26)			
40mm	TC_40x35	35	22	13	159	65	49	6	38	121	59	10	24,5	16	G 1/8	6	37	25	M6x1,0	35	66	52	6,5	M6x1,0	M5x0,8
					(6,26)	(2,56)	(1,93)	(.24)	(1,50)	(4,76)	(2,32)	(.39)	(1,00)	(.63)	(.24)	(1,46)	(.98)	x 14	(1,38)	(2,60)	(2,05)	(.26)			

Optional Imperial U.S. Thread Conversions:

MOUNTING HOLES: M3x0,5 = #6-32 M4x0,7 = #8-32 M5x0,8 = #10-24 M6x1 = 1/4-20
PORTS: M5x0,8 = #10-32 G 1/8 = 1/8-27 NPTF

ENGINEERING DATA

1. THEORETICAL CLAMP FORCE:
(with no clamp arm) = Pull Piston Area X Pressure
2. Use these charts to determine maximum operating pressures for clamp arm lengths. Operating pressures and arm lengths on or below the curves are safe operating zones.
3. As a result of friction and cantilevered clamping action, output force is not a straight line. Use these charts to determine safe operating zones for required clamp force.
4. If using a clamp arm more than 1.5 times dimension "A" of our standard "CA" option, flow controls must be used to reduce inertia during the turn stroke.
5. Double clamp arm, option "CAD", can be used to clamp two parts with one cylinder. However, clamp force is half of a single clamp arm. If using a double clamp arm longer than dimension "A" of our standard "CAD", flow controls must be used to reduce inertia during the turn stroke.

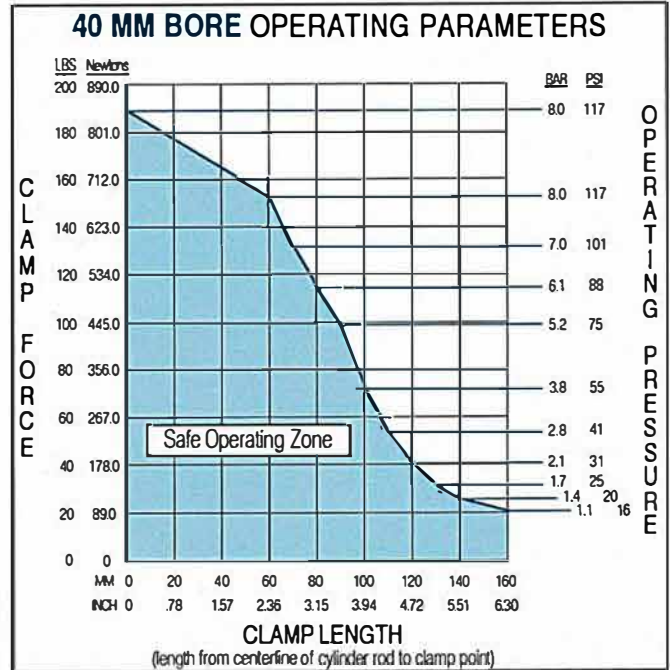
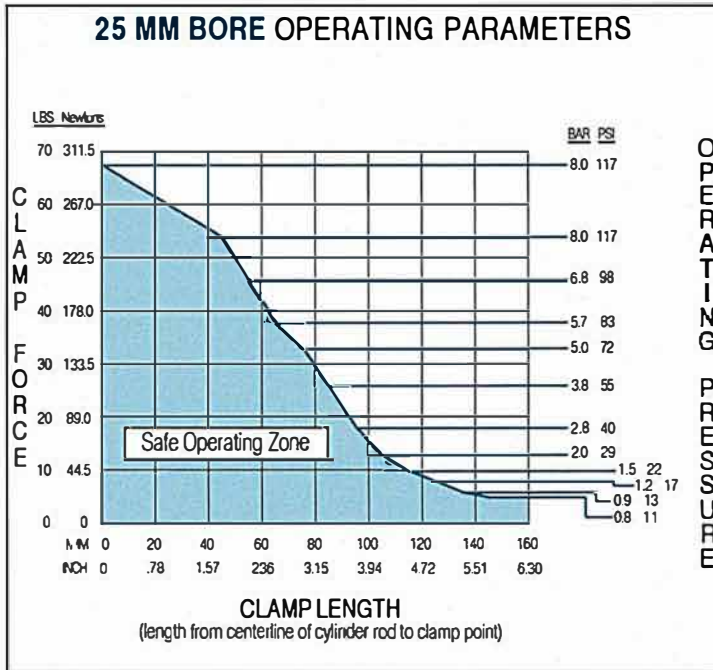
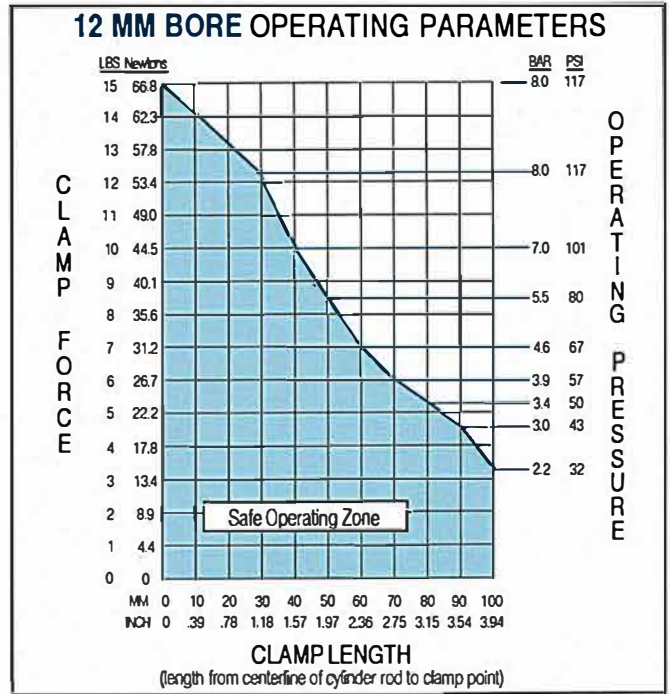

HOW TO ORDER - Example: ATCL25 x 30-CAD-TBE

A
MAGNETIC PISTON

Omit if not desired. See #METRIC catalog for details on Comtronic™ sensor option.

◆ TCL
STYLE

CODE	DESCRIPTION
TCL	Twist Cylinder Left Single rod end
TCLD	Twist Cylinder Left Double rod end
TCR	Twist Cylinder Right Single rod end
TCRD	Twist Cylinder Right Double rod end

25
BORE

CODE	DESCRIPTION
12	12 millimeter
25	25 millimeter
40	40 millimeter

x

30
STROKE

TOTAL STROKE	
BORE	STROKE
12mm	20mm
25mm	30mm and 35mm
40mm	30mm and 35mm

Specials Welcome

CAD
OPTION

SEALS
Standard -Buna-N 0° to 120°C (0° to 250°F)

OPTIONAL SEALS
Omit code if not desired

DESCRIPTION	CODE
Hi-Temp. Viton -10° to 200°C (0° to 400°F)	HTV
Hydraulic -10° to 120°C (0° to 250°F)	HYD
Hi-Temp. Viton Hyd. -10° to 200°C (0° to 400°F)	VHYD

HYD and VHYD not available on 12mm bore

US
OPTION

Omit code if not desired

CODE	DESCRIPTION
CA	Clamp Arm (Single)
CAD	Clamp Arm (Double)
FF	Front Flange
RF	Rear Flange
SB	Side Base
TBE	Threads Both Ends
TF	Threads Front
TR	Threads Rear
* US	Imperial Thread Option

◆ Must specify rotation for initial assembly. Cam is universal and may be converted after received.

CONVERSION FORMULAS
 BAR to PSI: 1 PSI = .069 BAR Example: 25 PSI x .069 = 1.7 BAR or 10 BAR x .069 = 145 PSI
 Fractional Inch to Millimeters: 1 inch = 25.4mm and 1mm ÷ 25.4 = 0.03937" Example: 12mm ÷ 25.4 = .47" or .75" x 25.4 = 19.05mm

* All tapped holes and ports converted to inches. See conversions on page 2

METRIC TWIST CYLINDER ACCESSORIES

DIMENSIONS SHOWN IN PARENTHESES () = INCH CONVERSIONS

Shown in First Angle Projection

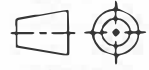

All dimensions in millimeters

OPTIONAL CLAMP ARMS

NOTE: Clamp arms are black oxidized steel - Clamp arm can be rotated to any position and locked down

SINGLE ARM Specify: "CA"

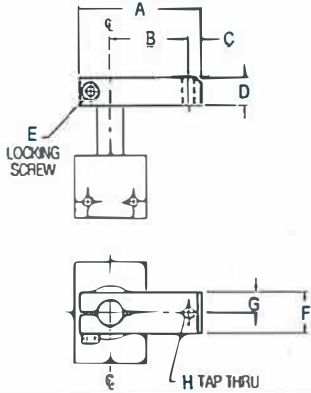

BORE	12	25	40
A	38 (1.50)	57 (2.24)	70 (2.76)
B	19 (.75)	35 (1.38)	43 (1.69)
C	6 (.24)	7 (.28)	7 (.28)
D	9.5 (.37)	12.7 (.50)	19 (.75)
E	M4x0.7	M5x0.8	M6x1.0
F	9.5 (.37)	19 (.75)	25.5 (1.00)
G	4.75 (.19)	9.5 (.37)	12.75 (.50)
H	M4x0.7	M6x1.0	M6x1.0

DOUBLE ARM Specify: "CAD"

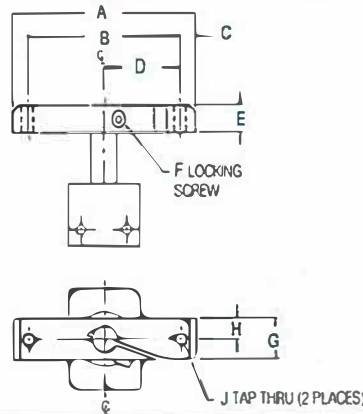

BORE	12	25	40
A	54 (2.12)	84 (3.31)	100 (3.94)
B	42 (1.65)	70 (2.75)	86 (3.38)
C	6 (.24)	7 (.28)	7 (.28)
D	21 (.83)	35 (1.38)	43 (1.69)
E	9.5 (.37)	12.7 (.50)	19 (.75)
F	M3x0.5	M5x0.8	M6x1.0
G	9.5 (.37)	19 (.75)	25.5 (1.00)
H	4.75 (.19)	9.5 (.37)	12.75 (.50)
J	M4x0.7	M6x1.0	M6x1.0

OPTIONAL MOUNTING

Side Base - Specify "SB"

Mounts two ways

NOTES:

Sold separately - not attached to cylinder for choice of mounting. Fasteners included. Material: black anodized aluminum

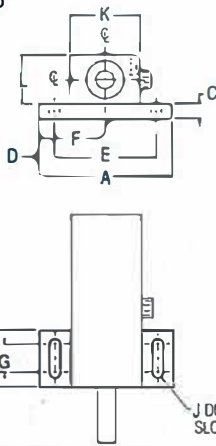

BORE	12	25	40
A	54 (2.12)	89 (3.50)	107 (4.21)
B	25.5 (1.00)	38.1 (1.50)	44.5 (1.75)
C	8 (.31)	9.5 (.37)	9.5 (.37)
D	7 (.28)	10.5 (.41)	10.5 (.41)
E	40 (1.57)	68 (2.68)	86 (3.38)
F	27 (1.06)	44.5 (1.75)	53.5 (2.11)
G	13.5 (.53)	19 (.75)	25.5 (1.00)
H	6 (.24)	9.5 (.37)	9.5 (.37)
J	4.8 (.19)	7.1 (.28)	7.1 (.28)
K	25.5 (1.00)	47 (1.85)	65 (2.56)
L	19 (.75)	33 (1.30)	49 (1.93)

Optional Mounting Patterns

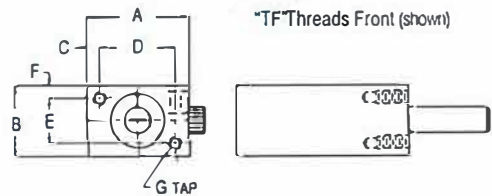

BORE	A	B	C	D	E	F	G
12	25.5 (1.00)	19 (.75)	3.7 (.15)	18 (.71)	12 (.47)	3.5 (.14)	M4 x 0.7
25	47 (1.85)	33 (1.30)	6 (.24)	35 (1.38)	21 (.83)	6 (.24)	M6 x 1.0
40	65 (2.56)	49 (1.93)	9.5 (.37)	46 (1.81)	32 (1.26)	8.5 (.33)	M6 x 1.0

"TR" Threads Rear



"TBE" Threads Both Ends

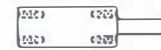

Rear Flange Specify: "RF" / Front Flange Specify: "FF"

12mm Bore

Example shown as "RF"

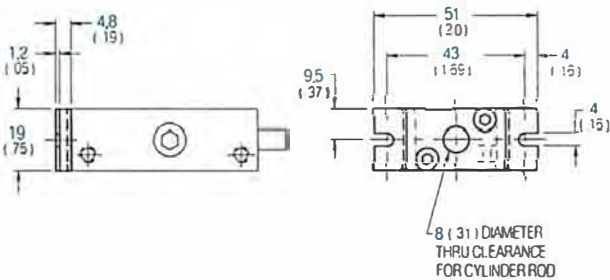

Material: Zinc Plated Steel

25mm Bore and up

Example shown as "RF"

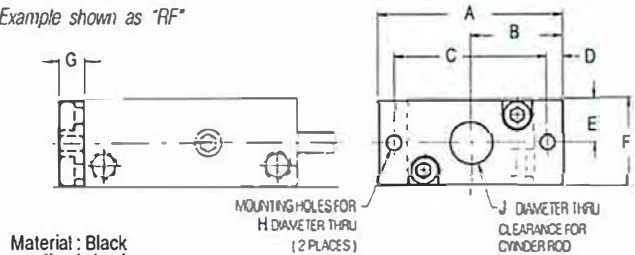

Material: Black anodized aluminum

BORE	A	B	C	D	E	F	G	H	J
25	69 (2.72)	34.5 (1.36)	57 (2.24)	6 (.24)	16.5 (.65)	33 (1.30)	9.5 (.37)	5.5 (.22)	16 (.63)
40	87 (3.43)	43.5 (1.71)	75 (2.95)	6 (.24)	24.5 (.95)	49 (1.93)	9.5 (.37)	5.5 (.22)	24 (.94)



CI SERIES

Compact Air Powered Oil Intensifiers

"Shop Air Pressure In . . . High Oil Pressure Out"

☆ Output pressure up to 5000 psi ☆ Volume from 1 in.³ to 9 in.³ ☆

INTRODUCTION:

CI SERIES Compact Intensifiers are simple generic boosters that utilize a large pneumatic piston (4", 6" or 8" diameter), to intensify oil pressure with a smaller piston (1-1/8" or 2" diameter).

The product range includes 24 models. All are designed to be highly space efficient and low weight. The pressure chamber features two large full flow ports for easy filling and bleeding.

The pneumatic actuator is our standard low profile large bore compact cylinder.

Features Include:

- Rugged space efficient, low weight aluminum design
- Long life / Low friction
- Three mounting choices
- Optional magnetic piston (Option "ACI")
- Cataloged sizes are stocked for prompt delivery
- Specials Welcome . . . Miniature sizes, special volumes, etc . . . Consult Factory



IMPORTANT

Standard Seals: Buna-N and Urethane
0° to 200°F Maximum (-17° to 93°C)

Viton Seals: Optional, although maximum output pressure not to exceed 2000 psi. Specify "HTV" after the part number.

MODULAR DESIGNS

OIL CHAMBERS

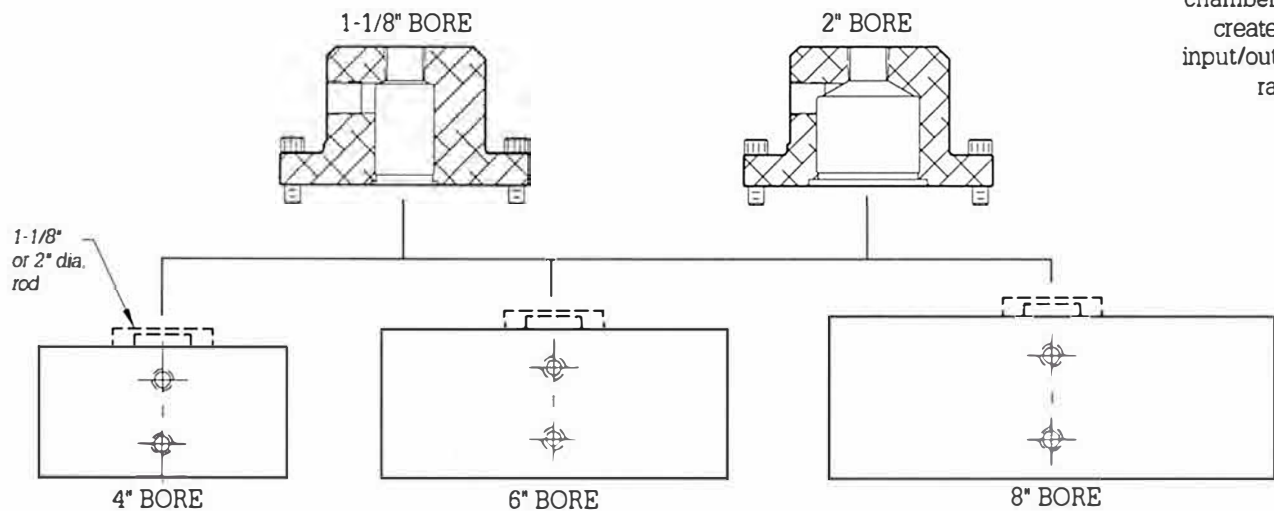

Mix and match actuators to pressure chambers to create six input/output ratios

LARGE PNEUMATIC PISTONS (NOTE: Available in 1" and 3" stroke)



P.O. Box 499, Westminster, SC 29693
Tel: 864-647-9521 Fax: 864-647-9574

GENERAL INFORMATION "CI" and "ACI" Series

Output Ratios

Our smallest intensifier has a ratio of 4 to 1. Our largest has a ratio of 50 to 1. The line offers 6 output ratios in all. Our modular design depicted on the cover illustrates how we have created the ratios. More information is given on the back cover.

Volume Displacement

Volume varies with each model, from 1 in.³ to 9 in.³. We recommend the use of at least 25% more volume than needed to satisfactorily do the job. For applications in which the volume exceeds 9 in.³, consult the factory for your options.

Speed Of Cycle

Typical pneumatic systems can cycle relatively quickly. Air powered oil systems are slower. Schematics #1 and #2 below show the two most typical applications. In both, the speed in which the oil is "pushed" back into the intensifier determines the cycle speed.

#1) DOUBLE ACTING CYLINDER - POWER EXTEND

Applications: Clamping Fixtures, Collet Closers, Grippers, Staking and Crimping Devices, Etc . . .

Using a simple 4-way pneumatic valve circuit, an intensified oil power stroke is created in one direction. Pneumatic power returns the cycle. Since the oil is pushed back into the intensifier by the cylinder, bigger cylinders will cycle faster than smaller ones. For fast cycling, use intensifiers in both directions.

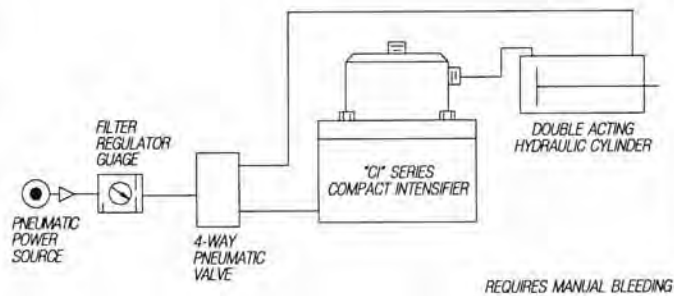

#2) SINGLE ACTING CYLINDER

Applications: Spring Loaded Clamping Devices
Using a simple 3-way pneumatic valve circuit, an intensified oil power stroke is created. The spring returns the cycle. Since the spring pushes the fluid back into the intensifier, cycle rate is relatively slow. Strong springs are needed. This system is ideal for short stroke / small fluid volume metal working clamp fixtures.

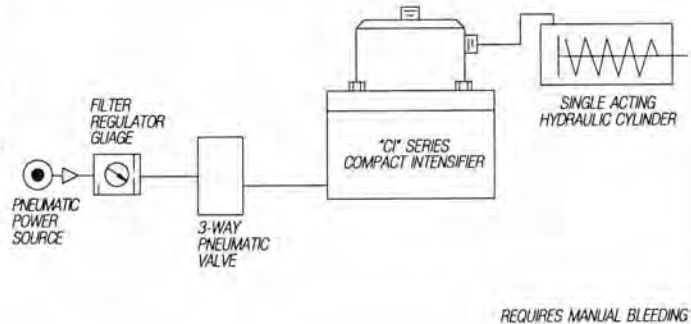

#3) SPECIAL APPLICATIONS

Applications: No flow constant pressure in a hydraulic system (shown). Also, burst testing, hydro static pressure testing, air powered air boosters, reciprocating boosters and many more. Consult the factory to discuss your unique application.

Example: The schematic to the right shows a hydraulic system that requires long clamping cycles. The intensifier maintains system pressure while pump is idle or off, compensating for fluid leakage. The low friction of our intensifier makes this application feasible.

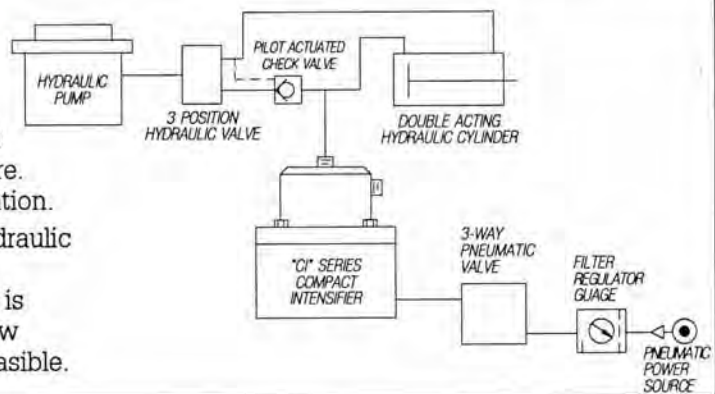

4" BORE POWERED INTENSIFIERS

Output Ratios include: 4:1 and 12:1

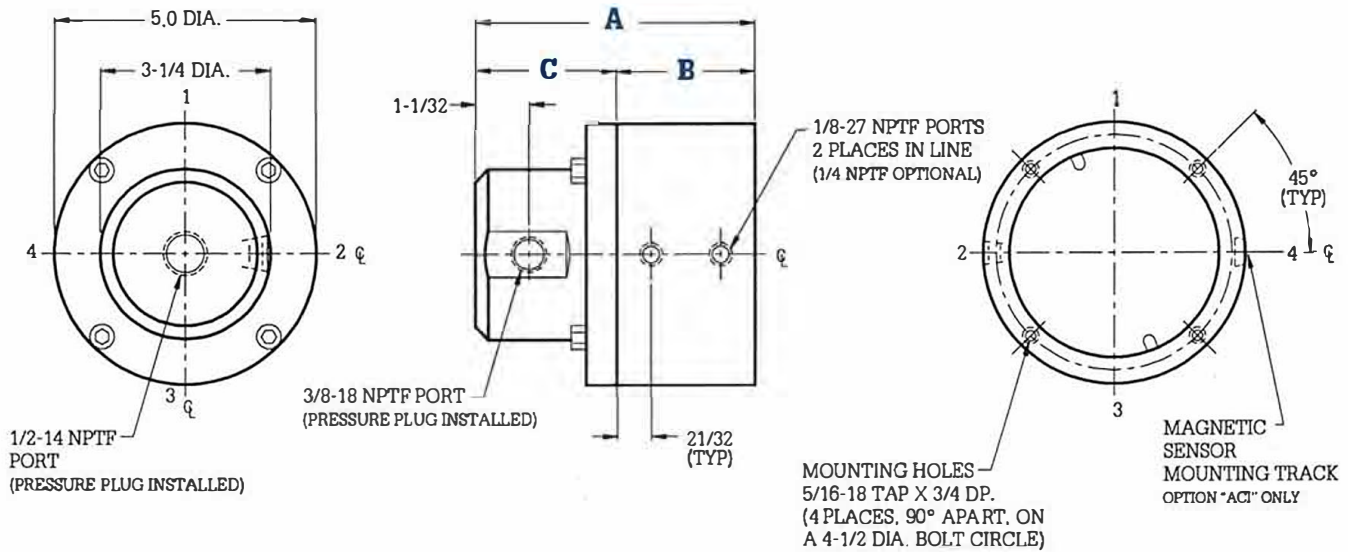

PART NUMBER	A	B	C	INPUT	OUTPUT	Output Volume	Approximate Unit Weight
				Max. Pneumatic Input Pressure Rating	Hydraulic Output Pressure		
CI-421-3	5-3/8	2-5/8	2-3/4	200 PSI	4 X INPUT	3 in. ³	8 Lbs.
*ACI-421-3	5-5/8	2-7/8					8-1/2 Lbs.
CI-421-9	9-3/8	4-5/8	4-3/4	200 PSI	4 X INPUT	9 in. ³	12-1/2 Lbs.
*ACI-421-9	9-5/8	4-7/8					13 Lbs.
CI-1221-1	5-3/8	2-5/8	2-3/4	200 PSI	12 X INPUT	1 in. ³	7-1/2 Lbs.
*ACI-1221-1	5-5/8	2-7/8					8 Lbs.
CI-1221-3	9-3/8	4-5/8	4-3/4	200 PSI	12 X INPUT	3 in. ³	11 Lbs.
*ACI-1221-3	9-5/8	4-7/8					11-1/2 Lbs.

*"ACI" boosters have a magnetic piston for limit sensing. See #Sensor bulletin for additional information

OPTIONAL FOOT MOUNT - Specify after the part number

"FM" - Foot Mount Front (shown) "FMR" - Foot Mount Rear
"FMB" - Foot Mount Both Ends

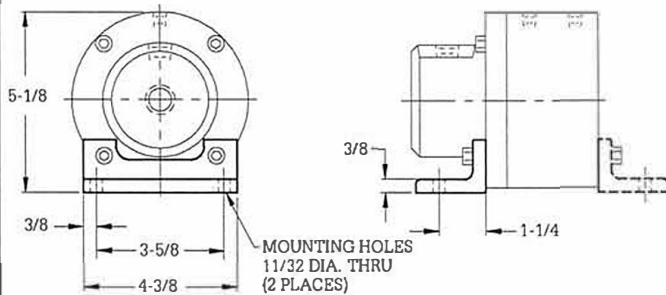

Note: Anodized aluminum

OPTIONAL MOUNTING FLANGE

Specify "RF" after the part number

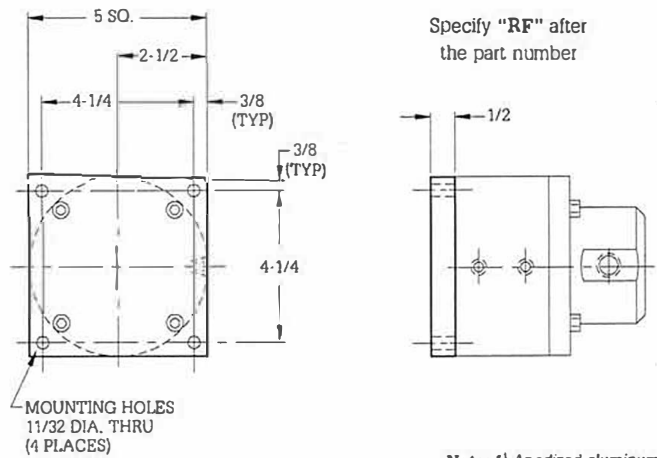

Note: 1) Anodized aluminum
2) May be rotated 90°

6" BORE POWERED INTENSIFIERS

Output Ratios include: 9:1 and 28:1

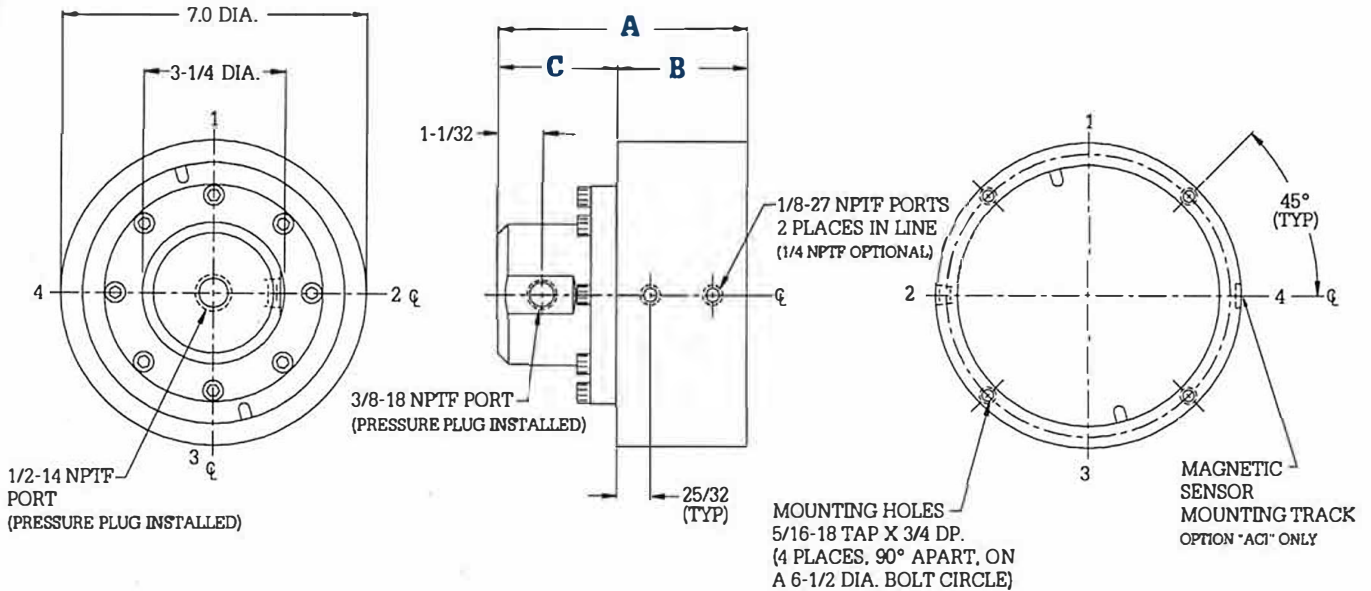

PART NUMBER	A	B	C	INPUT	OUTPUT	Output Volume	Approximate Unit Weight
				Max. Pneumatic Input Pressure Rating	Hydraulic Output Pressure		
CI-921-3	5-3/4	3	2-3/4	200 PSI	9 X INPUT	3 in. ³	13 Lbs.
*ACI-921-3	6	3-1/4					14 Lbs.
CI-921-9	9-3/4	5	4-3/4	200 PSI	9 X INPUT	9 in. ³	18 Lbs.
*ACI-921-9	10	5-1/4					19 Lbs.
CI-2821-1	5-3/4	3	2-3/4	175 PSI	28 X INPUT	1 in. ³	12 Lbs.
*ACI-2821-1	6	3-1/4					13 Lbs.
CI-2821-3	9-3/4	5	4-3/4	175 PSI	28 X INPUT	3 in. ³	16-1/2 Lbs.
*ACI-2821-3	10	5-1/4					17 Lbs.

*"ACI" boosters have a magnetic piston for limit sensing. See #Sensor bulletin for additional information

OPTIONAL FOOT MOUNT - Specify after the part number

"FM" - Foot Mount Front (shown) "FMR" - Foot Mount Rear
"FMB" - Foot Mount Both Ends

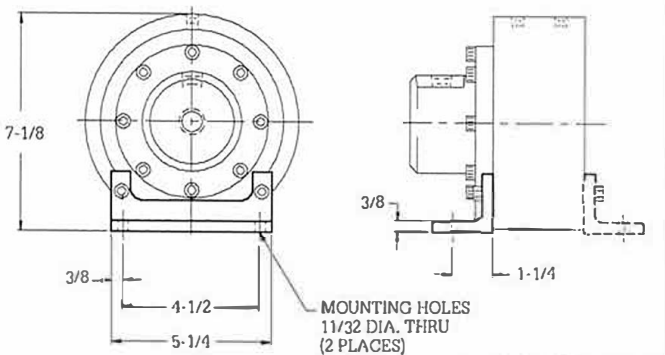

Note: Anodized aluminum

OPTIONAL MOUNTING FLANGE

Specify "RF" after the part number

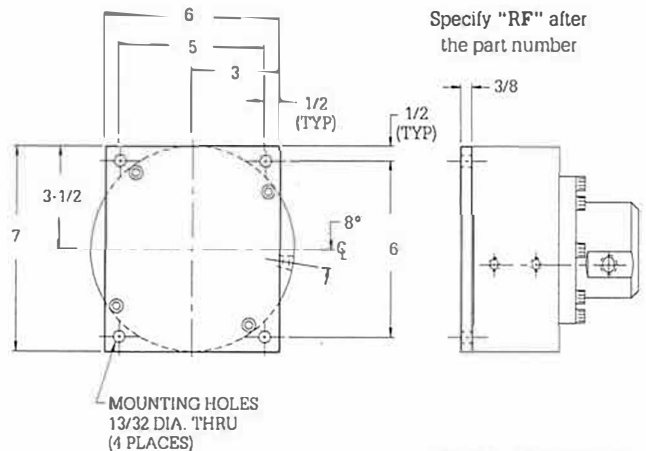

Note: 1) Black oxide steel
2) May be rotated 90°

8" BORE POWERED INTENSIFIERS

Output Ratios include: 16:1 and 50:1

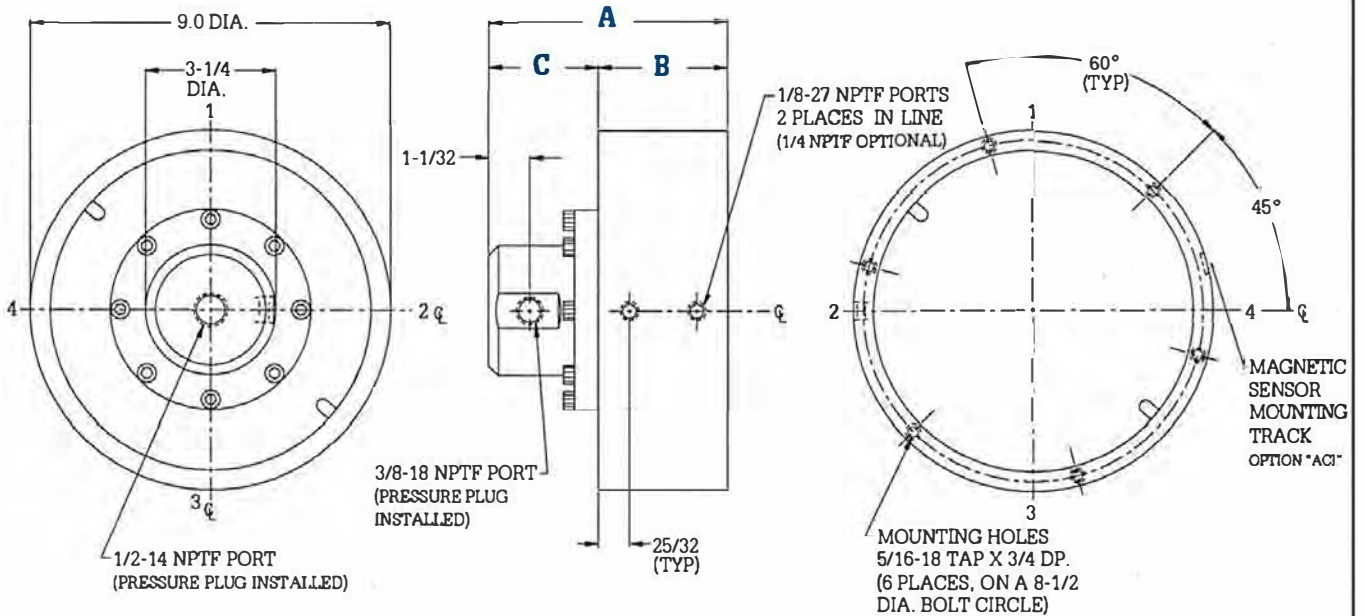

PART NUMBER	A	B	C	INPUT	OUTPUT	Output Volume	Approximate Unit Weight
				Max. Pneumatic Input Pressure Rating	Hydraulic Output Pressure		
CI-1621-3	6	3-1/4	2-3/4	200 PSI	16 X INPUT	3 in. ³	20 Lbs.
*ACI-1621-3	6-1/4	3-1/2					21-1/2 Lbs.
CI-1621-9	10	5-1/4	4-3/4	200 PSI	16 X INPUT	9 in. ³	25 Lbs.
*ACI-1621-9	10-1/4	5-1/2					26-1/2 Lbs.
CI-5021-1	6	3-1/4	2-3/4	100 PSI	50 X INPUT	1 in. ³	19 Lbs.
*ACI-5021-1	6-1/4	3-1/2					20-1/2 Lbs.
CI-5021-3	10	5-1/4	4-3/4	100 PSI	50 X INPUT	3 in. ³	23-1/2 Lbs.
*ACI-5021-3	10-1/4	5-1/2					25 Lbs.

*"ACI" boosters have a magnetic piston for limit sensing. See #Sensor bulletin for additional information

OPTIONAL FOOT MOUNT - Specify after the part number

"FM" - Foot Mount Front (shown) "FMR" - Foot Mount Rear
"FMB" - Foot Mount Both Ends

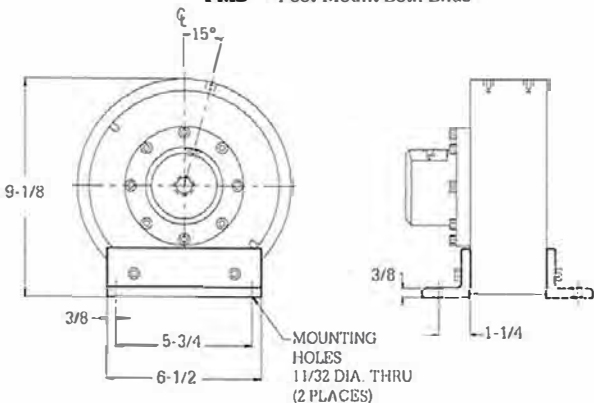

Note: Anodized aluminum

OPTIONAL MOUNTING FLANGE

Specify "RF" after the part number

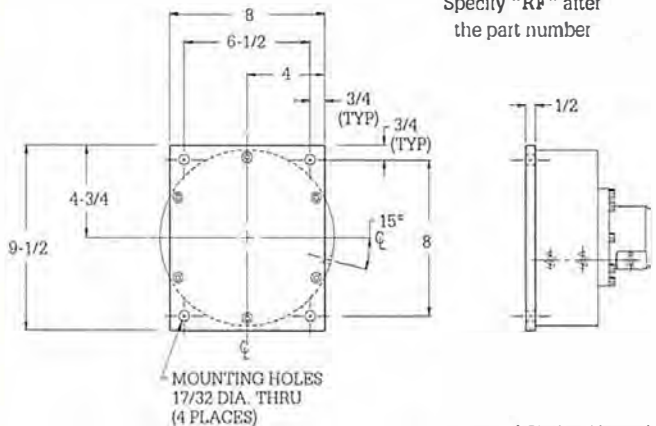

Note: 1) Black oxide steel
2) May be rotated 60°

BASIC INFORMATION

Explanation Of Part Numbers:

EXAMPLE: ACI-421-3-FMR

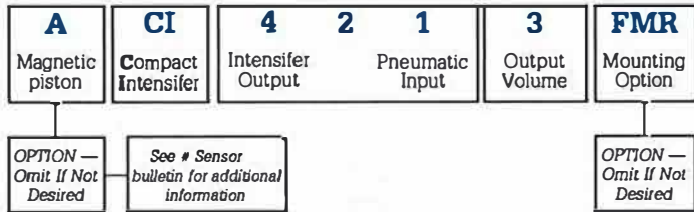

FORMULAS:

Intensifier Output Ratio:

$$\frac{\text{ACTUATOR PISTON AREA (IN.}^2\text{)}}{\text{OIL CHAMBER AREA (IN.}^2\text{)}} = \text{RATIO}$$

RATIO MULTIPLIED BY PSI = OUTPUT PRESSURE

Example:

$$\begin{aligned} 4^{\circ} \text{ Piston} &= \frac{12 \text{ in.}^2 \text{ area}}{3 \text{ in.}^2 \text{ area}} = \frac{4}{1} = 4 : 1 \text{ ratio or } 421 \\ 2^{\circ} \text{ Piston} &= \frac{3 \text{ in.}^2 \text{ area}}{1} = 3 : 1 \text{ ratio or } 321 \end{aligned}$$

$$4 \text{ (force)} \times 100 \text{ (psi)} = 400 \text{ psi OUTPUT}$$

Output Volume (in.³)

OIL CHAMBER AREA (IN.²) MULTIPLIED BY STROKE OF ACTUATOR (IN.) = VOLUME (IN.³)

$$\text{Example: } 3 \text{ in.}^2 \times 1 \text{ in.} = 3 \text{ in.}^3 \text{ of VOLUME}$$

Oil Chambers

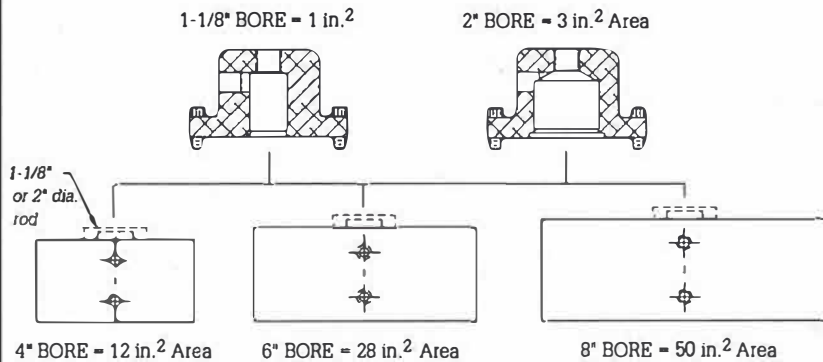

Large Pneumatic Actuators (NOTE: Available in 1" and 3" stroke)

Pneumatic Input: Clean, dry or lubricated compressed air from 3 PSI up to maximum rating. Maximum input ratio is based on NOT exceeding 5000 PSI output. Consult the factory when using compressed gases other than "shop air".

Hydraulic Output: We recommend a non-detergent medium weight oil for best results. The pressure seal is urethane so fluids must be compatible. The maximum pressure with the urethane seal is 5000 PSI.

☆ Important: Viton is offered as an optional seal for high temperature or unique fluid compatibility, although maximum pressure is only 2000 PSI

TYPICAL APPLICATION

AIR POWERED OIL INTENSIFIER

"Gang Mounted" Collet Closers

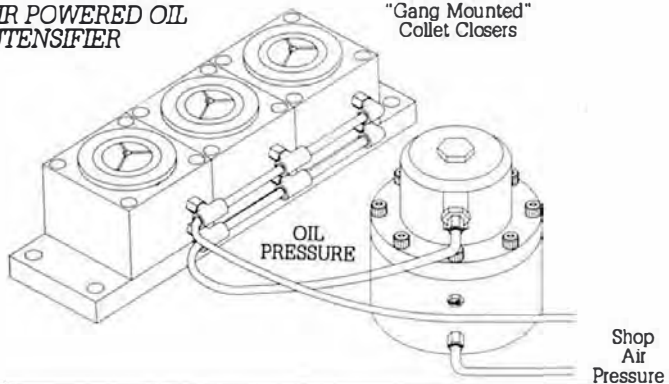

SPECIALS WELCOME!

- ☆ Corrosion Resistant Stainless Steel
- ☆ Special Volume or Output Ratios
- ☆ Miniature and Sub-miniature Sizes from 1/2" Piston Diameter
- ☆ SAE "O-ring" Pressure Ports
- ☆ Seal Materials



Compact Automation Products, LLC
105 Commerce Way
Westminster, SC 29693
Tel: 864.647.9521
Fax: 864.647.9574
www.compactautomation.com