

ITT Turn-Act Products



ITT

ENGINEERED FOR LIFE

Table of Contents

Compact (CA) Series

Overview	pg. 2
How to Order	pg. 3
Dimensions	pg. 4

Turn-Act (TA) Series

Overview	pg. 6
How to Order	pg. 7
Dimensions	pg. 8

Brute Series

Overview	pg. 10
How to Order	pg. 11
Dimensions	pg. 12

Options

Flange	pg. 14
Combination Flange	pg. 15
Side Angle Mounts	pg. 16
Extended Tie Rods	pg. 17
Side Mounts	pg. 18
Dowel Pin Locator	pg. 19
Three Hole Face Mount and Low Profile Actuators	pg. 20
Adjustable Stroke Control	pg. 21
Thrust Protection	pg. 22
Internal Rotation Stop	pg. 23
Urethane Bumpers	pg. 23
Motion Control Package	pg. 23
Switches	pg. 24-29
Potentiometers & Encoders	pg. 29
Port Locations/Types	pg. 30
Namur Mount	pg. 30
Shaft Modifications	pg. 32-33
Shaft Accessories	pg. 34-35
Three Position Actuator Systems	pg. 36
Hydraulic Service Rotary Actuators	pg. 37
Stainless Steel Actuators	pg. 37
Actuators for Special Environments	pg. 37
Clean Series	pg. 38
Systems	pg. 39

Turn-Dex

Turn-Dex 1-1/4" Bore	pg. 40
How to Order	pg. 41
Dimensions	pg. 42

Turn-Dex 2-1/2" Bore	pg. 43
How to Order	pg. 44
Dimensions	pg. 45
Adjustable Stroke Control (ASC)	pg. 46

Turn-Dex Options

Flange Mount	pg. 47
Side Angle Mounts	pg. 48
Side Mounts	pg. 49
Thrust Protection	pg. 50
Cap Sensor Systems	pg. 51
Trantorque®	pg. 52
Hub Adapter	pg. 53

Class Act (CL) Valve Operator

Specifications	pg. 54
How to Order	pg. 55

Value-U-Act (VA) Valve Operator

Specifications	pg. 56
How to Order	pg. 57

Val-U-Act (VS) Spring Return

How to Order	pg. 58
--------------------	--------

Warranty Statement	pg. 60
--------------------------	--------

Comp-Act (CA) Series

ROTARY VANE ACTUATORS:

- 15 base models with torque outputs from 9 in. lbs. to 100 in. lbs.
- Rotations 90, 180 & 270 degrees.

As compared to other rotary devices... Turn-Act Vane Actuators have:

- One moving part providing:
 - ZERO Backlash.
 - No loss of motion.
 - Smooth Rotation.
 - Precise Repeatability.
 - Continuous full torque throughout rotation.
- Turn-Act Patented Urethane seals for:
 - Long cycle life and Non-lube service.
 - Actual applications with 25 million cycles and more.
- 100s of standard options and modifications.

Just imagine... How TURN-ACT Answer Engineering can work for you!



COMP-ACT ACTUATOR WITH OPTIONAL ADJUSTABLE STROKE CONTROL

Torque Chart (IN. LBS.)			
180° and 270° Rotations ²			
Actuator Model	Actuator Torque at		
	100 PSI	80 PSI	60 PSI
011	9	7	5
013			
021	13	10	8
023			
031	25	20	15
033			
041	32	26	19
043			
061	50	40	30
063			

Torque Chart (IN. LBS.)			
90° Rotations ²			
Actuator Model	Actuator Torque at		
	100 PSI	80 PSI	60 PSI
012	17	14	10
022	32	26	19
032	44	35	26
042	60	48	36
062	100	80	60

SPECIFICATIONS

Unit Materials

Stator/Rotor Seals... Urethane
 Shaft/Tube Seals..... Buna¹
 Shaft..... 303 Stainless Steel
 Body..... Anodized Alum.
 Bearings..... Full Comp. Needle

Miscellaneous

Inlets..... 1/8 NPT
 Min. Pressure..... 35 psi
 Max. Pressure..... 200 psi
 Cylinder Bore..... 1-1/4"

Shaft Load Capacities

Max. Side Load..... 250 lbs.
 Max. End Load..... 10 lbs.

Temperature Range

-20°F to 180°F. Consult factory for higher temperature.

Filtration

Air..... 25-50 microns

Cycle Rates³

Max. non-lubed rate:

90° Rot..... 40 cpm
 180°, 270° Rot..... 20 cpm

Max. lubed rate:

Consult Factory

Rotary Motion Backlash

All models 0 degree

Leak Rates

Air..... 4 cfm or less @ 100 psi

- 1 Viton Optional
- 2 All rotations are nominal +4/-0 actual
- 3 Cycle = Start position to end of rotation and returning to the start position.
Stroke = 1/2 cycle

Capacity per Stroke ³ (IN ³)			
270° Rotation ²		90° Rotation ²	
011	0.50	012	0.42
021	0.99	022	0.84
031	1.49	032	1.26
041	1.99	042	1.68
061	3.49	062	2.96

Weights (OZs)			
270° Rotation ²		90° Rotation ²	
011	8	012	8
021	10	022	10
031	12	032	12
041	14	042	14
061	18	062	18

How to Order: Comp-Act (CA)

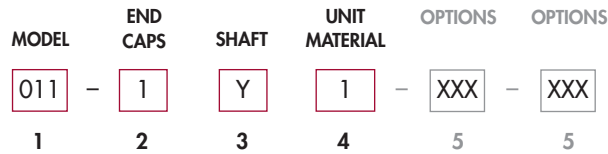

1

Model			
Model	Series	Torque	Rotation
011	CA	09	270
012	CA	17	90
013	CA	09	180
021	CA	13	270
022	CA	25	90
023	CA	13	180
031	CA	25	270
032	CA	44	90
033	CA	25	180
041	CA	32	270
042	CA	60	90
043	CA	32	180
061	CA	50	270
062	CA	100	90
063	CA	50	180

2

End Caps	
To Specify other modifications; Consult Factory	
1	Pneumatic
2	Pneumatic - Low Profile
4	Pneumatic - w/ Vacuum Ports

3

Shaft	
To Specify other modifications; Consult Factory	
Y	Single End - No Keyway
M	Double End - No Keyway Each End
W	Single End - Woodruff Key
V	Double End - Woodruff Key Each End
U	Single End - Shaft Flat
T	Double End - Shaft Flat Each End
S	Single End - Keyway
R	Double End - Keyway Each End

4

Unit Materials	
Shaft - Body - Trim	
1	303 Stainless Steel - Anodized Aluminum - Carbon Steel
3	303 Stainless Steel - Anodized Aluminum - Stainless Steel
4	303 Stainless Steel - Stainless Steel - Stainless Steel
6	316 Stainless Steel - 316 Stainless Steel - Stainless Steel

5

Options	
Additional options available on pgs. 14-33	
000	No Options
100	Flange Mount - Rod End
101	Flange Mount - Cap End
300	Extended Tie Rods - Rod End
301	Extended Tie Rods - Cap End
400	Adjustable Stroke Control - Cap End, Pos.5
401	Adjustable Stroke Control - Rod End, Pos.1
801	Side Mounts - Positions 2 & 6
803	Side Mounts - Positions 4 & 8
804	Side Mounts - Positions 2,4,6 & 8
900	Thrust Protection - Cap End, Pos.1
901	Thrust Protection - Rod End, Pos.1
B00	Urethane Bumpers
T01	3/8" Trantorque® Shaft Coupler - Carbon Steel
T02	3/8" Trantorque® Shaft Coupler - Stainless Steel <small>Stainless Shaft Coupler has 1/3 the Transmissible Torque as T01 (see pgs. 34-35)</small>

Switch Options	
Additional switch options available on pg. 24	
All Axx Switch Options are Single End Only	
A00	Switch Package - No Switches
A02	Switch Pkg. - 2 Reed Switches
A05	Switch Pkg. - 2 Sourcing Switches
A08	Switch Pkg. - 2 Sinking Switches
Double end switch options available on pgs. 25-26	

Dimensional Data: Comp-Act (CA)

Basic Dimensions

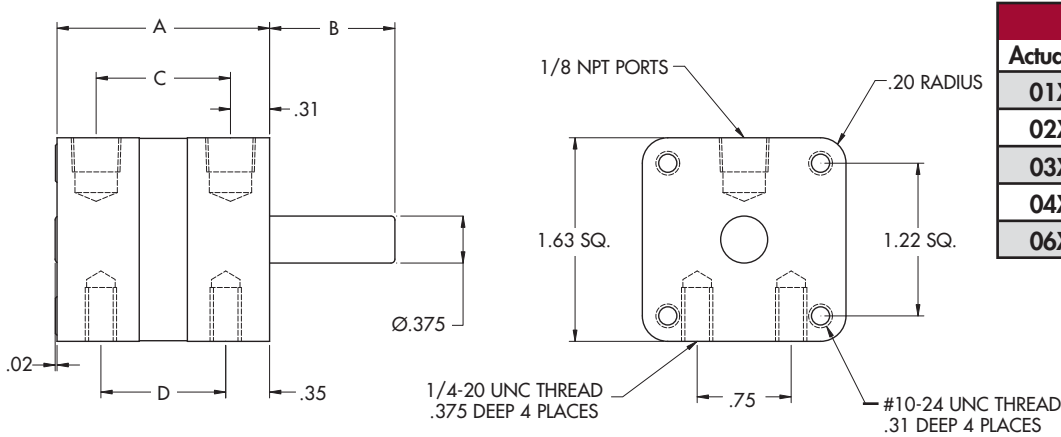

Dimensional Specifications				
Actuator	A	B	C	D
01X	1.70	1.00	1.07	1.00
02X	2.20	1.00	1.57	1.50
03X	2.70	1.00	2.07	2.00
04X	3.20	1.00	2.57	2.50
06X	4.75	1.00	4.12	4.05

Shaft Options

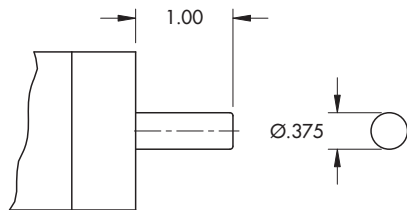

Basic Shaft

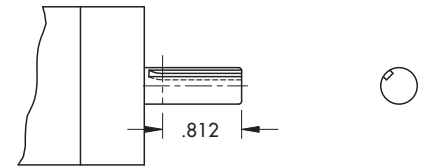

$3/32$ " Square Keyway

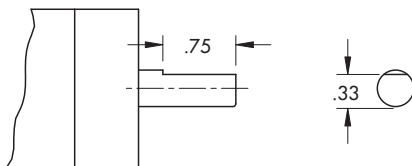

Shaft Flat

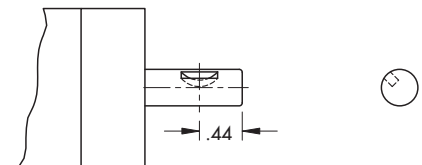

#303 Woodruff Key

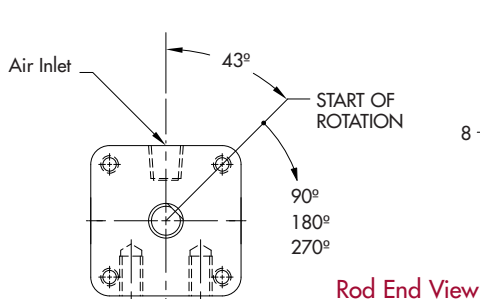

Rod End View

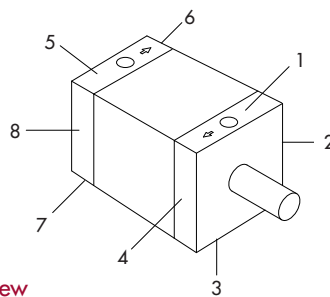

Port & Mounting Position References

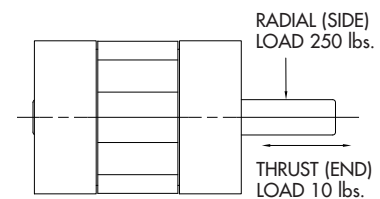

Shaft Load Capacity

Nominal Rotations (+4/-0 actual)

NOTE: The 43° start position is nominal. Tolerances are +/- 2 degrees.

Can You Imagine...

ANSWER ENGINEERING®

The ability to rapidly and accurately modify our products to better meet the requirements of your application.

Frequently, a simple modification; a shorter shaft, a relocated mounting hole or perhaps a change in port size, results in an actuator that will better fit your application. To modify most other manufacturers products is time consuming and expensive. Turn-Act's manufacturing processes are designed to address rapid, accurate, and cost effective production of custom modified rotary actuators.

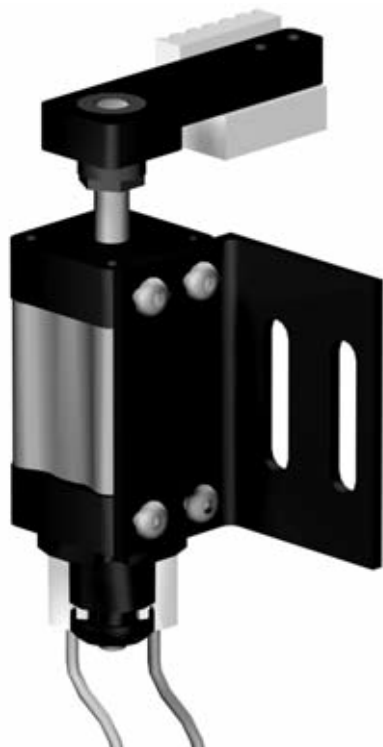

Imagine... Clean Room Application

To address the demanding requirements of a clean room application, Turn-Act designed and produced a Conveyor stop sub-assembly.

This assembly consists of:

- 60 in. lbs. 90° rotary actuator
- An adjustable mounting bracket designed to integrate with the conveyor rail
- Stop Arm
- Trantorque™ shaft coupling
- Arm end-effector to interface with conveyed product

The purchase of this sub-assembly resulted in cost reductions for the customer by eliminating and minimizing:

- Design costs
- Fabrication costs
- Assembly/Install costs
- Inventory costs

THIS IS... Turn-Act Answer Engineering®

Imagine... Medical Application

To contend with the repeatability and space constraints of a small desktop medical analysis device, Turn-Act designed and produced this SPECIAL Actuator Assembly.

This assembly consists of:

- 60 in. lbs. 90° rotary actuator
- Combined rod head and flange mount
- Shaft modification included:
 - Extended length
 - Turn down
 - Threaded end
 - Cross drilled hole
 - Assembly of a shaft bushing and cross pin
- Special switch system and connectors
- Preset adjustable stroke control

Cost reduction is always a priority, however this application had the additional constraints of size and a need for 100% repeatability. Turn-Act provided a product that met all of these requirements.

THIS IS... Turn-Act Answer Engineering®

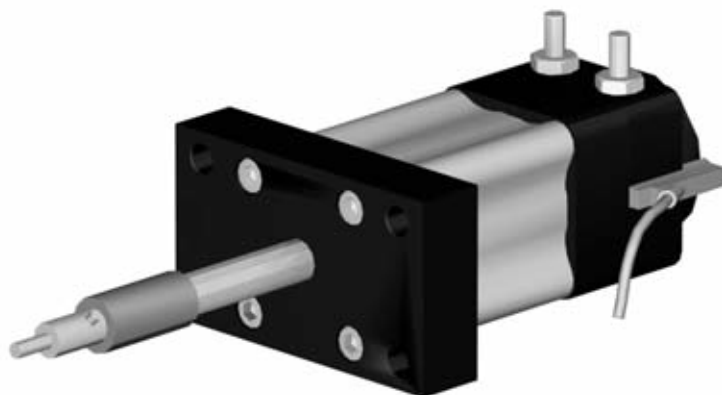

Turn-Act® (TA) Series

ROTARY VANE ACTUATORS:

- 16 base models with torque outputs from 87 in. lbs. to 1000 in. lbs.
- Rotations 45, 90, 180 & 270 degrees.

As compared to other rotary devices... Turn-Act Vane Actuators have:

- One moving part providing:
 - ZERO Backlash.
 - No loss of motion.
 - Smooth Rotation.
 - Precise Repeatability.
 - Continuous full torque throughout the rotation.
- Patented Urethane seals for:
 - Long cycle life and Non-lube service.
 - Actual applications with 25 million cycles and more.
- 100s of standard options and modifications.

Just imagine... How TURN-ACT Answer Engineering can work for you!

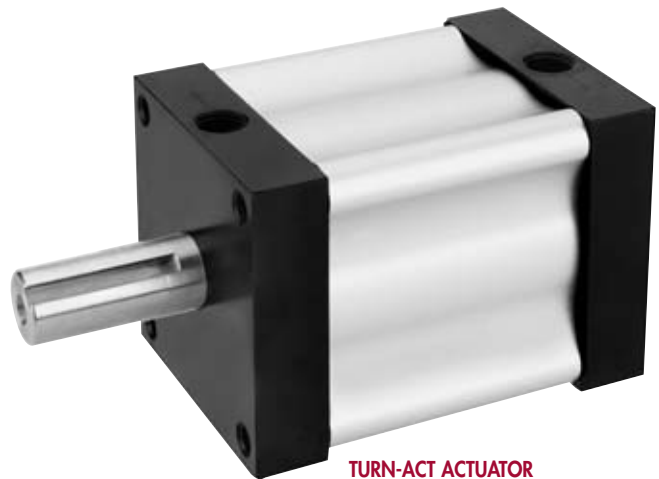

TURN-ACT ACTUATOR
NO OPTIONS SELECTED

Torque Chart (IN. LBS.)			
180° and 270° Rotations ²			
Actuator Model	Actuator Torque at		
	100 PSI	80 PSI	60 PSI
111	87	70	52
113			
121	175	140	105
123			
131	350	280	210
133			
141	500	400	300
143			

Torque Chart (IN. LBS.)			
45° AND 90° Rotations ²			
Actuator Model	Actuator Torque at		
	100 PSI	80 PSI	60 PSI
112	175	140	105
114			
122	350	280	210
124			
132	700	560	420
134			
142	1000	800	600
144			

SPECIFICATIONS

Unit Materials

Stator/Rotor Seals...Urethane
 Shaft/Tube Seals.....Buna¹
 Shaft.....Polished & Ground,
 Fatigue Proof 1144
 Body.....Anodized Alum.
 Bearings....Full Comp. Needle

Miscellaneous

Inlets.....1/4 NPT
 Min. Pressure35 psi
 Max. Pressure200 psi⁴
 Cylinder Bore.....2-1/2"

Shaft Load Capacities

Max. Side Load.....500 lbs.
 Max. End Load.....25 lbs.

Temperature Range

-20°F to 180°F. Consult factory for higher temperature.

Filtration

Air.....25-50 microns
 Hydraulic.....10-25 microns

Cycle Rates

Max. non-lubed rate:
 45°, 90° Rot.....40 cpm
 180°, 270° Rot.....20 cpm

Max. lubed rate:
 Consult Factory

Rotary Motion Backlash

All models0 degree

Leak Rates

Air....4 cfm or less @ 100 psi
 Hydraulic..0.5 cfm @ 500 psi

Hydraulic Service

Available for 11x and 12x size Turn-Act rotaries only. Use of paraffin based hydraulic oil is recommended. DO NOT USE skydrol, brake fluid, water based fluid, S or F type automatic transmission fluid.

- 1 Viton Optional
- 2 All rotations are nominal +4/-0 actual
- 3 Cycle = Start position to end of rotation and returning to the start position. Stroke = 1/2 cycle
- 4 Pressure Rating for 11X and 12X is 500psi max.

Capacity per Stroke ³ (IN ³)			
270° Rotation ²		90° Rotation ²	
111	4.52	112	2.75
121	8.50	122	5.50
131	17.00	132	11.00
141	27.50	142	16.70

Weights (LBS.)			
270° Rotation ²		90° Rotation ²	
111	2.5	112	2.5
121	3.3	122	3.3
131	6.0	132	6.0
141	9.3	142	9.3

How to Order: Turn-Act® (TA)

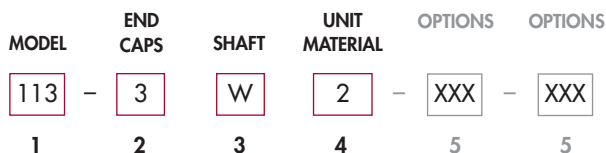

1 Model

Model	Series	Torque	Rotation
111	TA	- 87	- 270
112	TA	- 175	- 90
113	TA	- 87	- 180
114	TA	- 175	- 45
121	TA	- 175	- 270
122	TA	- 350	- 90
123	TA	- 175	- 180
124	TA	- 350	- 45
131	TA	- 350	- 270
132	TA	- 700	- 90
133	TA	- 350	- 180
134	TA	- 700	- 45
141*	TA	- 500	- 270
142*	TA	- 1000	- 90
143*	TA	- 500	- 180
144*	TA	- 1000	- 45

* These models require '2' or '5' for the selection in block #4 "Unit Materials".

2 End Caps
To Specify other modifications; Consult Factory

1	Pneumatic
2	Pneumatic - Low Profile
3	Hydraulic - w/ Drain Ports
4	Pneumatic - w/ Vacuum Ports

3 Shaft
To Specify other modifications; Consult Factory

Y	Single End - No Keyway
M	Double End - No Keyway Each End
W	Single End - Woodruff Key
V	Double End - Woodruff Key Each End
U	Single End - Shaft Flat
T	Double End - Shaft Flat Each End
S	Single End - Keyway
R	Double End - Keyway Each End
G	Single End With Manual Override

4 Unit Materials
Shaft - Body - Trim

1	Polished & Ground Fatigue Proof 1144 Steel - Anodized Aluminum - Carbon Steel
2	Hardened Carbon Steel - Anodized Aluminum - Carbon Steel
3	303 Stainless Steel - Anodized Aluminum - Stainless Steel
4	303 Stainless Steel - 303 Stainless Steel - Stainless Steel
5	Hardened 440 SS - Anodized Aluminum - Stainless Steel
6	316 Stainless Steel - 316 Stainless Steel - Stainless Steel

5 Options
Additional options available on pgs. 14-33

000	No Options
100	Flange Mount - Rod End
101	Flange Mount - Cap End
200	Side Angle Mounting Brackets - Mounting Surface 3 & 7
300	Extended Tie Rods - Rod End
301	Extended Tie Rods - Cap End
320	Extended Tie Rods - Both Ends
400	Adjustable Stroke Control - Cap End, Pos. 5
401	Adjustable Stroke Control - Rod End, Pos. 1
500	Electrical Position Indicator - Cap End, Pos. 5
704	Teflon Impregnated Hard Anodized
801	Side Mounts - Positions 2 & 6
803	Side Mounts - Positions 4 & 8
804	Side Mounts - Positions 2, 4, 6 & 8
900	Thrust Protection - Cap End, Pos. 1
901	Thrust Protection - Rod End, Pos. 1
B00	Urethane Bumpers
T01	3/4" Trantorque® Shaft Coupler - Carbon Steel
T02	3/4" Trantorque® Shaft Coupler - Stainless Steel Stainless Shaft Coupler has 1/3 the Transmissible Torque as T01 (see pgs. 34-35)
Switch Options Additional switch options available on pg. 24 All Axx Switch Options are Single End Only	
A00	Switch System -No Switches
A02	Switch System -2 Reed Switches
A05	Switch System -2 Sourcing Switches
A08	Switch System -2 Sinking Switches
Double end switch options available on pgs. 25-26	

Dimensional Data: Turn-Act® (TA)

Basic Dimensions

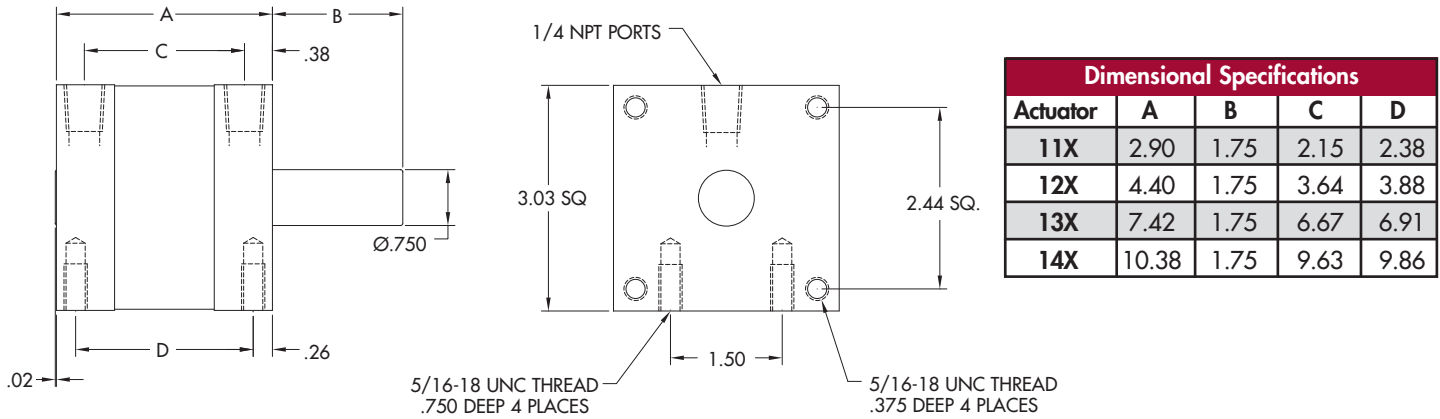

Shaft Options

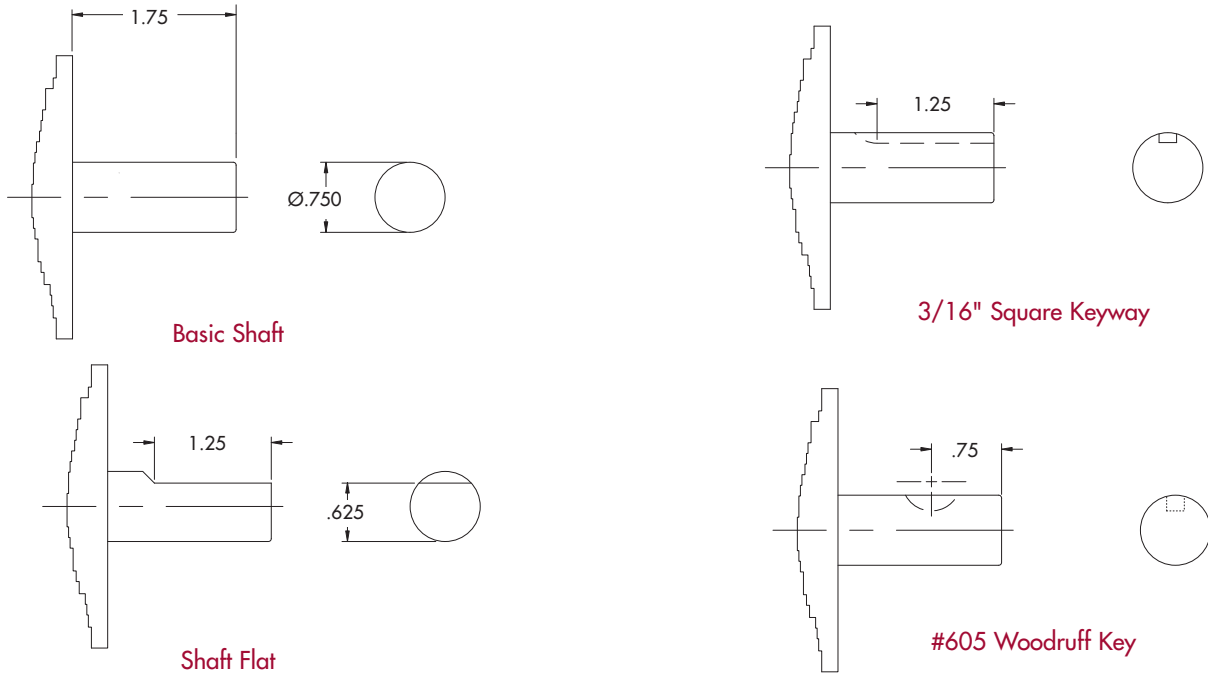

NOTE: Center drill omitted from shaft details for clarity.

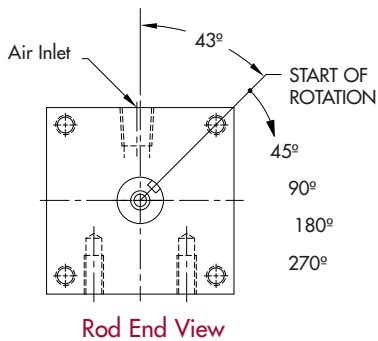

Rod End View

Nominal Rotations (+4/-0 actual)

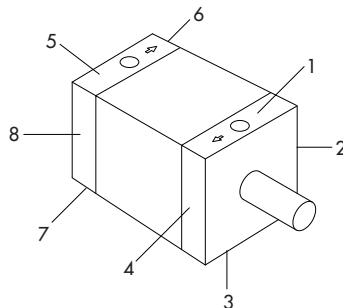

Port & Mounting Position References

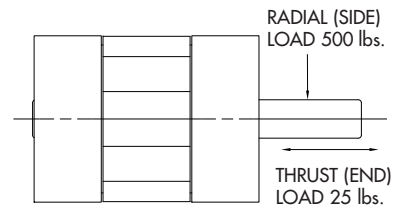

Shaft Load Capacity

NOTE: The 43° start position is nominal. Tolerances are +/- 2 degrees.

Can You Imagine...

ANSWER ENGINEERING®

The ability to rapidly and accurately modify our products to better meet the requirements of your application.

Frequently, a simple modification; a shorter shaft, a relocated mounting hole or perhaps a change in port size, results in an actuator that will better fit your application. To modify most other manufacturers products is time consuming and expensive. Turn-Act's manufacturing processes are designed to address rapid, accurate, and cost effective production of custom modified rotary actuators.

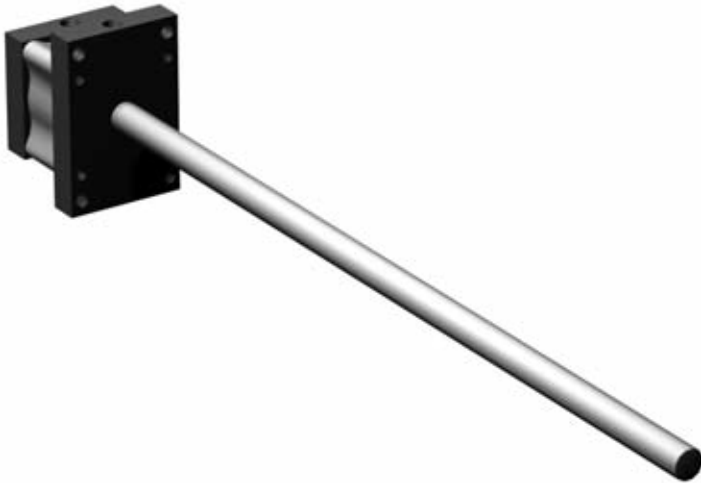

Imagine... Vibratory Conveyor Diverter Application

To meet the demanding requirements of a 24-hour 7-day a week vibrating conveyor application, Turn-Act developed this SPECIAL Actuator.

This assembly consists of:

- 175 in. lbs. 90° rotary actuator
- Combined rod head and flange mount with special port location
- Shaft modified to 32" overall length

Reduced cost was the primary goal of this modified actuator. The simple shaft extension allowed for the elimination of a secondary shaft, shaft coupling, shaft bearing, brackets and the labor associated with assembling and aligning these components. This system of fewer parts and connections results in a more reliable and cost effective system.

THIS IS... Turn-Act Answer Engineering®

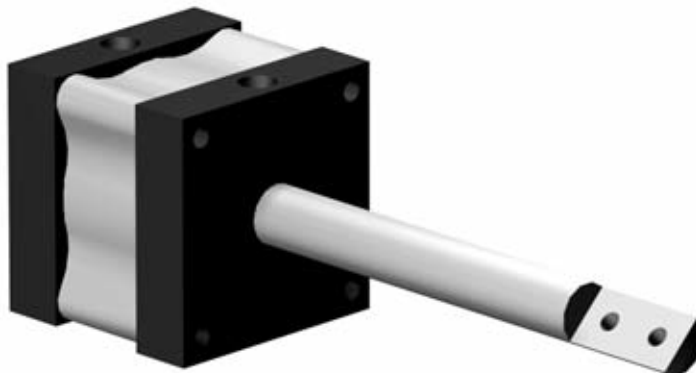

Imagine... Abrasive/High Particulate Environment

Some of the most abusive environments can be found in the paper, wood products, bakery, and foundry industries. Migrating particulates can be the cause of premature equipment failure in these applications.

To address these environmental issues, Turn-Act developed this SPECIAL Actuator.

This assembly consists of:

- 175 in. lbs. 90° rotary actuator
- Shaft modification included:
 - 6" Extended length with a 1.5" flat
 - Tapped holes for end effector attachment
- Rod Seal – modified for abusive environments
- Blind cap head

Improved actuator life and system cost reductions were the primary goals of this modified actuator. Overall, the design provided extended cycle life by limiting particulate entry points and reduced costs associated with assembling the components.

THIS IS... Turn-Act Answer Engineering®

How to Order: Brute (BR)

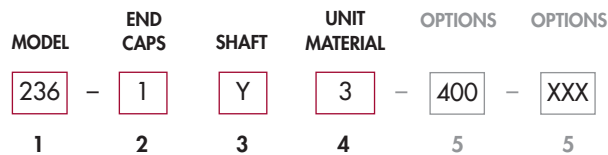

1

Model			
Model	Series	Torque	Rotation
221	BR	400	270
222	BR	800	90
223	BR	400	180
225	BR	400	290
226	BR	800	110
231	BR	750	270
232	BR	1500	90
233	BR	750	180
235	BR	750	290
236	BR	1500	110
241	BR	1300	270
242	BR	2600	90
243	BR	1300	180
245	BR	1300	290
246	BR	2600	110
251	BR	1950	270
252	BR	3900	90
253	BR	1950	180
255	BR	1950	290
256	BR	3900	110
261	BR	2600	270
262	BR	5200	90
263	BR	2600	180
265	BR	2600	290
266	BR	5200	110

2

End Caps	
To Specify other modifications; Consult Factory	
1	Pneumatic - Black Anodized
4	Pneumatic - Black Anodized - Vacuum Port

3

Shaft	
To Specify other modifications; Consult Factory	
Y	Single End - No Keyway
M	Double End - No Keyway Each End
W	Single End - Woodruff Key
V	Double End - Woodruff Key Each End
S	Single End - Keyway
R	Double End - Keyway Each End

4

Unit Materials	
Shaft - Body - Trim	
1	Polished & Ground Fatigue Proof 1144 Steel - Anodized Aluminum - Carbon Steel
3	303 Stainless Steel - Anodized Aluminum - Stainless Steel
4	303 Stainless Steel - 303 Stainless Steel - Stainless Steel
6	316 Stainless Steel - 316 Stainless Steel - Stainless Steel

5

Options	
Additional options available on pgs. 14-33	
000	No Options
100	Flange Mount - Rod End
101	Flange Mount - Cap End
300	Extended Tie Rods - Rod End
301	Extended Tie Rods - Cap End
401	Adjustable Stroke Control - Rod End, Pos. 1
501	Electrical Position Indicator - Rod End, Pos. 1
704	Teflon Impregnated Hard Anodizing
801	Side Mounts - Positions 2 & 6
803	Side Mounts - Positions 4 & 8
804	Side Mounts - Positions 2,4,6 & 8
B00	Urethane Bumpers
T01	1-1/4" Trantorque® Shaft Coupler - Carbon Steel
T02	1-1/4" Trantorque® Shaft Coupler - Stainless Steel Stainless Shaft Coupler has 1/3 the Transmissible Torque as T01 (see pgs. 34-35)
Switch Options	
Additional switch options available on pg. 24	
All Axx Switch Options are Single End Only	
A00	Switch Package - No Switches
A02	Switch Pkg. - 2 Reed Switches
A05	Switch Pkg. - 2 Sourcing Switches
A08	Switch Pkg. - 2 Sinking Switches
Double end switch options available on pgs. 25-26	

Dimensional Data: Brute (BR) Series

BRUTE (BR) Series

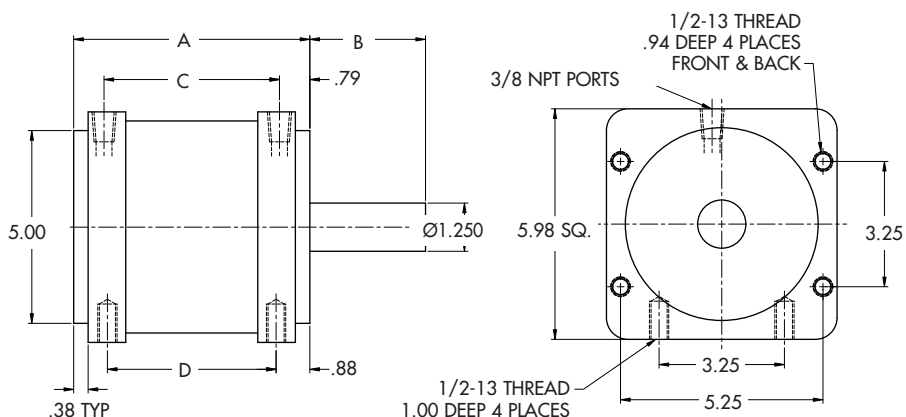

Dimensional Specifications				
Actuator	A	B	C	D
22X	4.37	3.00	2.80	2.62
23X	6.12	3.00	4.55	4.37
24X	8.62	3.00	7.05	6.87
25X	11.64	3.00	10.07	9.89
26X	14.64	3.00	13.07	12.89

SHAFT OPTIONS

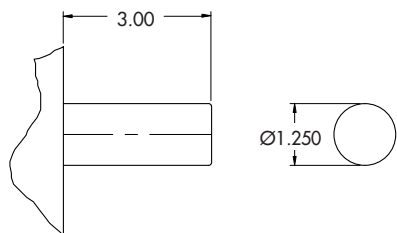

Basic Shaft

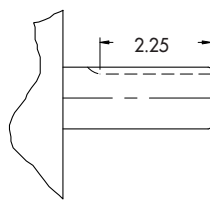

1/4" Square Keyway

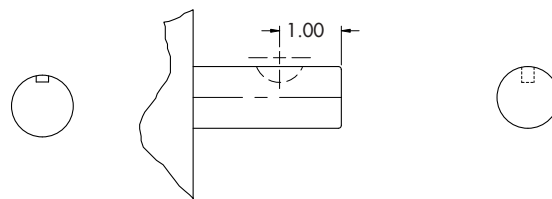

#808 Woodruff Key

NOTE: Center drill omitted from shaft details for clarity.

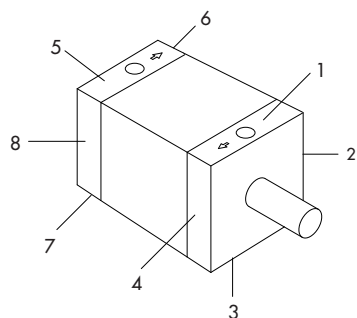

Port & Mounting Position References

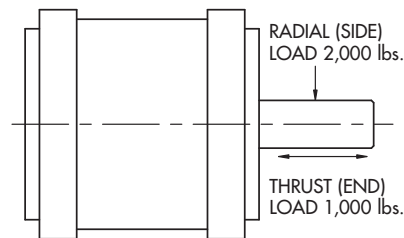

Shaft Load Capacity

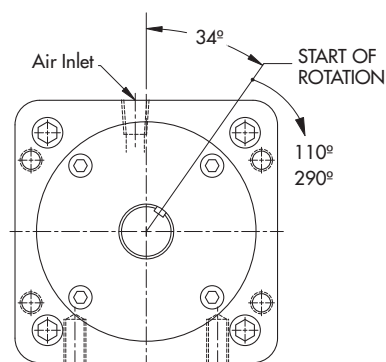

Nominal Rotations (+4/-0 actual)

Rod End Views

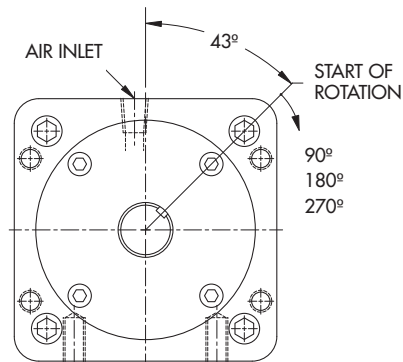

Nominal Rotations (+4/-0 actual)

NOTE: The 34° and 43° start position are nominal. Tolerances are +/- 2 degrees.

Can You Imagine...

ANSWER ENGINEERING®

The ability to rapidly and accurately modify our products to better meet the requirements of your application.

Frequently, a simple modification; a shorter shaft, a relocated mounting hole or perhaps a change in port size, results in an actuator that will better fit your application. To modify most other manufacturers products is time consuming and expensive. Turn-Act's manufacturing processes are designed to address rapid, accurate, and cost effective production of custom modified rotary actuators.



Imagine... Product Transfer Application

Consistent around the clock throughput is critical to a profitable plastics molding operation. Turn-act developed this SPECIAL Actuator to meet the needs of the high speed mold sweep application.

This unit consists of:

- 2600 in. lbs. 110° rotation
- Shaft modification:
 - 33" Extended length

Long cycle life, repeatability, and cost per cycle are the prime considerations of this modified actuator. The simple shaft extension allowed the elimination of a secondary shaft, shaft coupling, shaft bearing and brackets. Fewer component parts produced a more reliable and repeatable system while reducing the final installed cost.

THIS IS... Turn-Act Answer Engineering®



Imagine... Food Process/Wash down Application

Food contact and caustic wash down are some of the parameters that must be addressed when designing machinery for the food industry. Turn-Act developed this Special Actuator for this type of manufacturing environment.

This unit consists of:

- 2600 in. lbs. 180° rotation
- Stainless shaft and fasteners
- Heads sealed for wash down
- Shaft modification included:
 - Double end, extended length with ground tolerances to run in an external bearing set.
- Teflon® impregnated hard anodizing for caustic washdown

Improved actuator life and system cost reductions were the primary goals of this modified actuator. Overall, the design provided extended cycle life by limiting wash fluid entry points and reduced costs associated with assembling the components.

THIS IS... Turn-Act Answer Engineering®

Options- Flange Mount

COMP-ACT (CA) Series

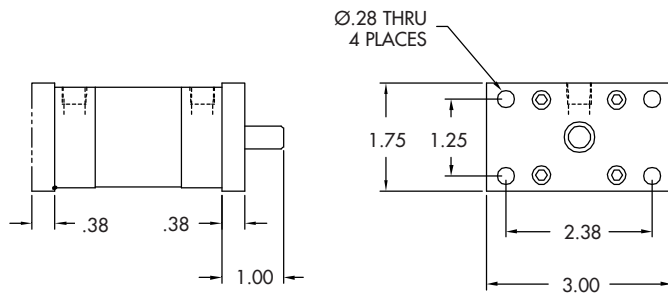

NOTE: Side Mounts surface 3 & 7 are standard, but are not shown for clarity. Standard Bottom Mount dimensions shown on page 4.

TURN-ACT (TA) Series

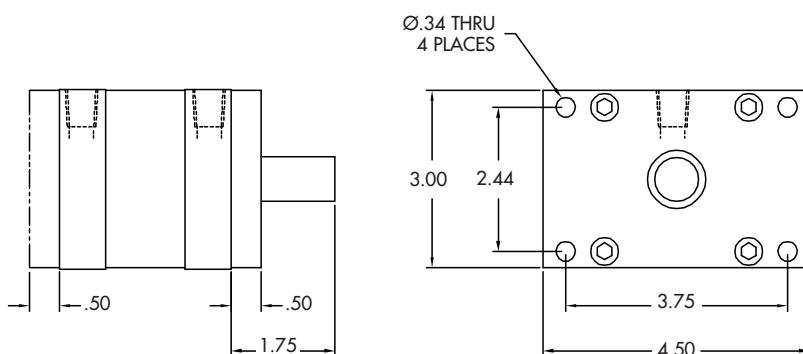

NOTE: Side Mounts surface 3 & 7 are standard, but are not shown for clarity. Standard Bottom Mount dimensions shown on page 8.

BRUTE (BR) Series*

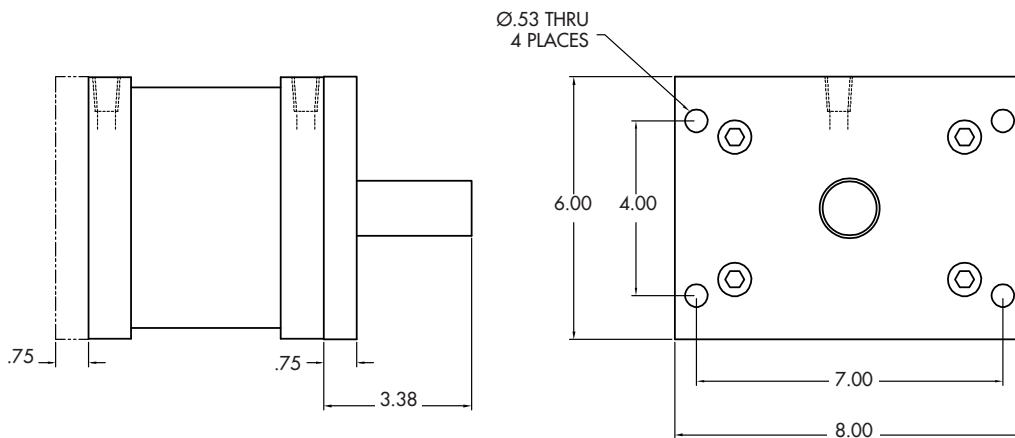

NOTE: The Flange Mount option and Adjustable Stroke Control option may not be ordered on the same end of a unit.

NOTE: Side Mounts surface 3 & 7 are standard, but are not shown for clarity. Standard Bottom Mount dimensions shown on page 12.

Option#	Description
100	Front Flange
101	Rear Flange
102	Front and Rear Flange
Front Flange and Front ASC Combined (See page 15)	

*NOTE: When ordering Brute with Flange Mount the bearing retaining plate is eliminated. The flange itself serves as the retainer.

Options- Combination Flange

The flange option can be combined with either head, or the Adjustable Stroke Control housing of the actuator to minimize the overall length of the actuator.

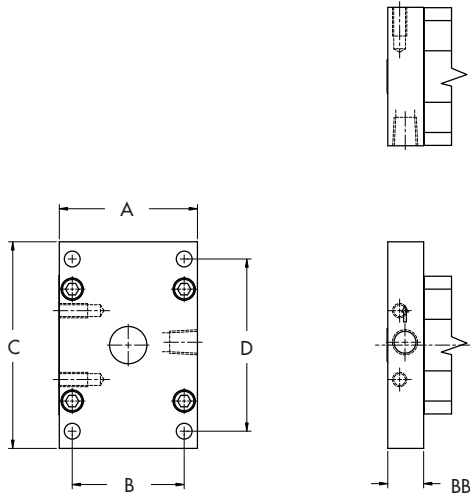

TURN-ACT ACTUATOR WITH INTEGRAL RODHEAD FLANGE OPTION, PORT ON SHORT SIDE.

Combination Flange/Rod Head: Port shown on long side.

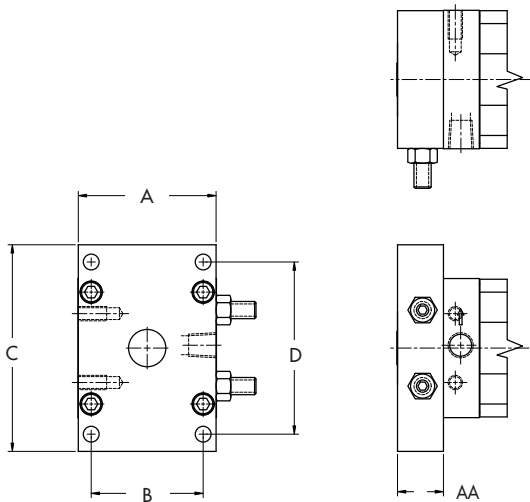

Combo Flanges	Comp-Act (CA) Series	Turn-Act (TA) Series	Brute (BR) Series
A	1.65	3.00	6.00
B	1.25	2.44	4.00
C	3.00	4.50	8.00
D	2.38	3.75	7.00
EE	0.28	0.34	0.53
ASC Flange (AA)	0.656	1.000	1.50
Flange Head (BB)	0.656	0.781	0.975

Combination Flange/Adjustable Stroke Control (ASC) Housing:
The ASC housing and the flange are machined from a single piece of aluminum.

Option #	Description
105	Flange Mount integral with the Adjustable Stroke Control Housing Front Mount.
108	Flange Mount integral with the Adjustable Stroke Control Housing Rear Mount.
110	Flange Mount integral with the Rod Head. Flange positioned with the port on the Short side.
111	Flange Mount integral with the Cap Head. Flange positioned with the port on the Short side.
120	Flange Mount integral with the Rod Head. Flange positioned with the port on the Long side.
121	Flange Mount integral with the Cap Head. Flange positioned with the port on the Long side.

Options- Side Angle Mounts

Option #	Description
200	Side Angle Brackets, Mounting Surface 3 & 7
201	Side Angle Brackets, Mounting Surface 2 & 6
202	Side Angle Brackets, Mounting Surface 4 & 8
203	Side Angle Brackets, Mounting Surface 1 & 5

NOTE: Specify the surface to be used for mounting. Example: Option 200 would call out surface 3 & 7 as the mounting surface, Option #201 would call out surface 2 & 6 as the mounting surface.

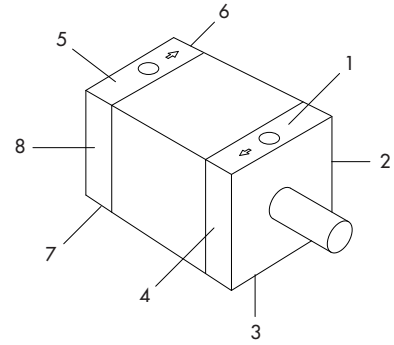

Mounting Surface Reference Drawing

TURN-ACT (TA) Series

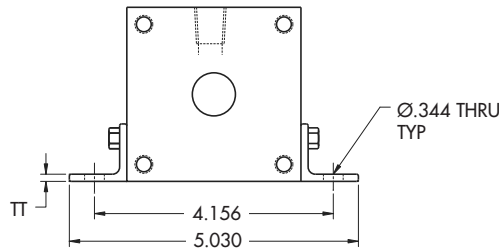
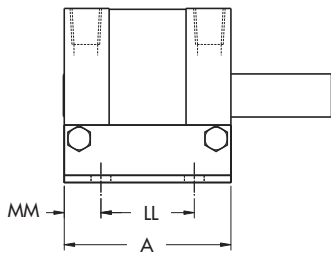

Option 200
Shown in Drawing

Turn-Act Model	A	LL	MM	TT
11X	2.90	1.625	.638	.125
12X	4.39	3.000	.694	.125
13X	7.42	6.000	.712	.125
14X	10.38	9.125	.626	.188

BRUTE (BR) Series

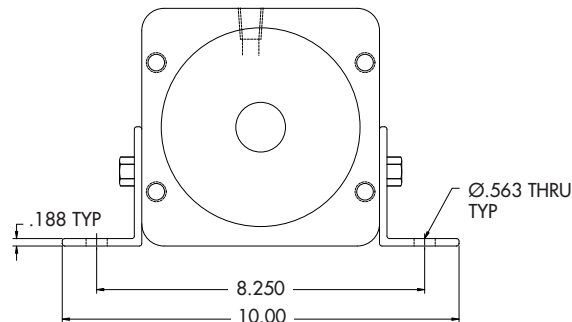
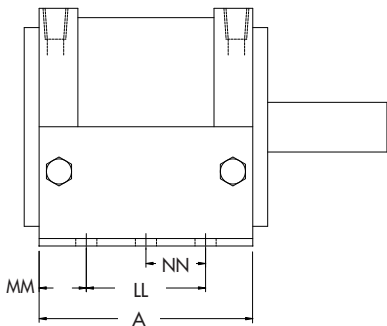

Option 200
Shown in Drawing

Brute Model	A	LL	MM	NN
22X	3.63	1.625	1.000	N/A
23X	5.38	3.375	1.000	N/A
24X	7.88	4.875	1.500	N/A
25X	10.88	7.875	1.500	3.938
26X	13.88	10.875	1.500	5.438

Options- Extended Tie Rods

Option #	Description
300	Extended Tie Rods, Front
301	Extended Tie Rods, Rear
302 ¹	Extended Tie Rods, Front and Rear

NOTE: Tie rod material (Carbon Steel or Stainless Steel) is determined by the Unit Material selected for the base actuator. The Extended Tie Rod option eliminates the standard front mounts.

1. Option 302 is not available on the Comp-Act Series actuators. Consult Factory for other variations of this option.

COMP-ACT (CA) Series

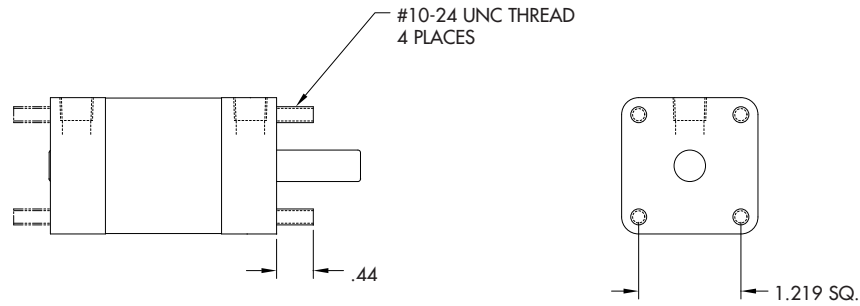

TURN-ACT (TA) Series

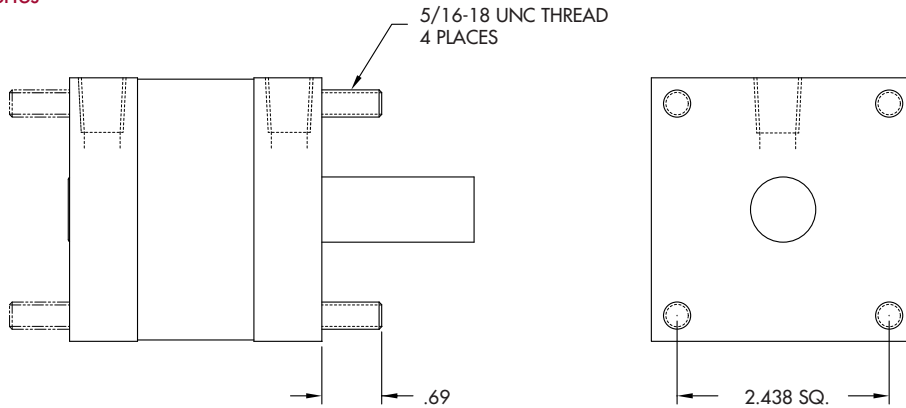

BRUTE (BR) Series

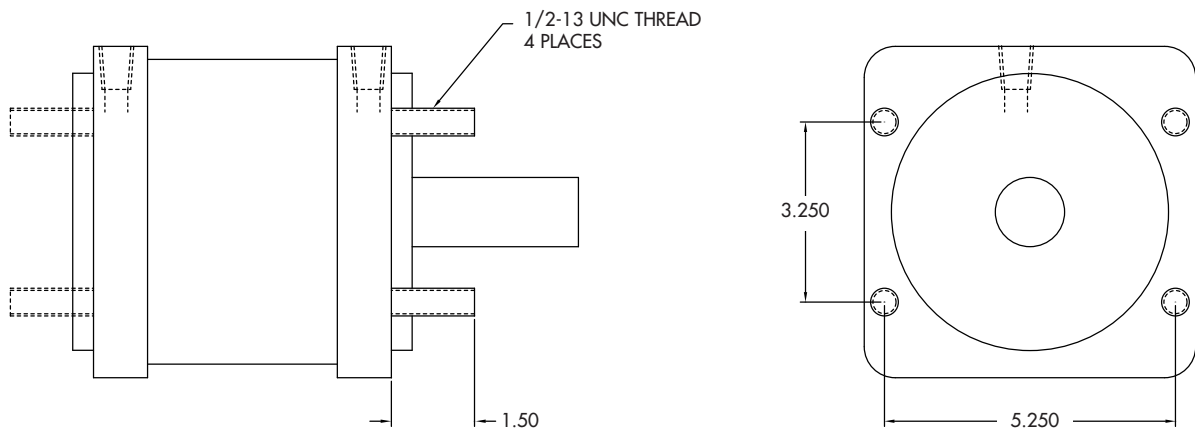

Options- Side Mounts

Option #	Description
SIDE MOUNTS, SIDES 3 & 7 STANDARD ON ALL MODELS	
800	Side Mounts, Sides 1 & 5
801	Side Mounts, Sides 2 & 6
803	Side Mounts, Sides 4 & 8
804	Side Mounts, Sides 2, 4, 6 & 8
806	Side Mounts, Sides 6 & 8
807	Side Mounts, Sides 2 & 4
810	No Side Mounts

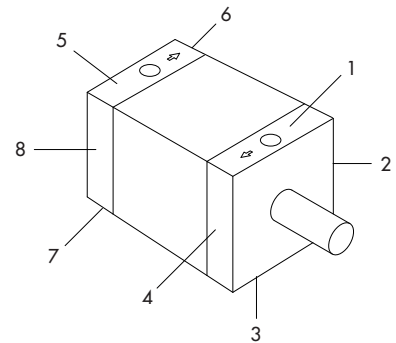

Position Reference Drawing

NOTE: Specify the side to be used for mounting. Example: Option 804 would call out sides 2, 4, 6 & 8 as the mounting surfaces, as depicted in the drawings below. Mount sides 3 & 7 are standard on all models (CA, TA, BR) but are not shown for clarity.

COMP-ACT (CA) Series

Comp-Act Models	D
01X	1.00
02X	1.50
03X	2.00
04X	2.50
06X	4.05

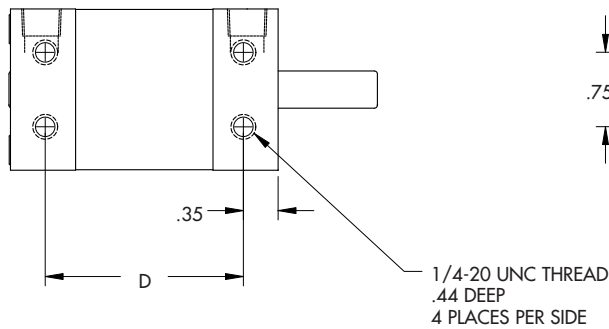

NOTE: Mounts surface 3 & 7 are standard, but are not shown for clarity. Standard Bottom Mount dimensions shown on page 4.

TURN-ACT (TA) Series

Turn-Act Models	D
11X	2.38
12X	3.87
13X	6.91
14X	9.86

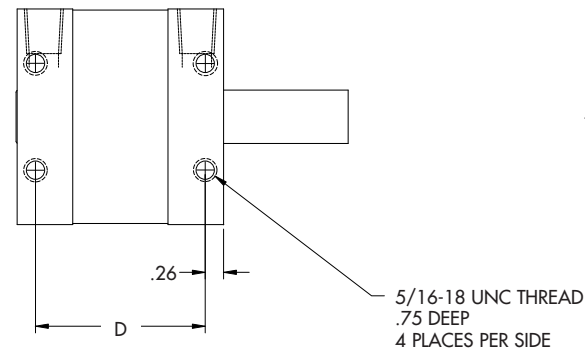

NOTE: Mounts surface 3 & 7 are standard, but are not shown for clarity. Standard Bottom Mount dimensions shown on page 8.

NOTE: Center drill omitted from shaft details for clarity.

BRUTE (BR) Series

Brute Models	D
22X	2.63
23X	4.38
24X	6.88
25X	9.88
26X	12.88

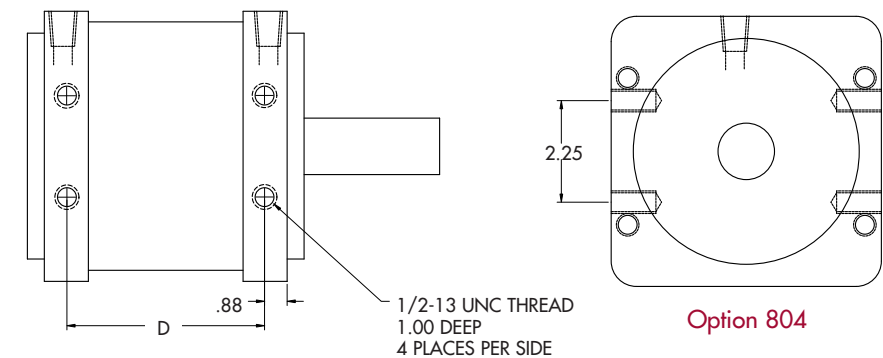

NOTE: Mounts surface 3 & 7 are standard, but are not shown for clarity. Standard Bottom Mount dimensions shown on page 12.

NOTE: Center drill omitted from shaft details for clarity.

Options- Dowel Pin Locators

Option #	Description
805	Dowel Pin Locator, Sides 3 & 7
811	Dowel Pin Locator, Sides 2 & 6
812	Dowel Pin Locator, Sides 4 & 8

COMP-ACT (CA) Series

Comp-Act Models	PP
01X	0.996
02X	1.496
03X	1.996
04X	2.496
06X	4.048

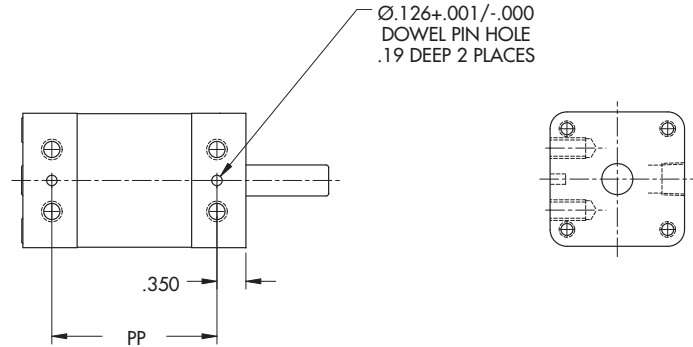

TURN-ACT (TA) Series

Turn-Act Models	PP
11X	2.384
12X	3.877
13X	6.907
14X	9.860

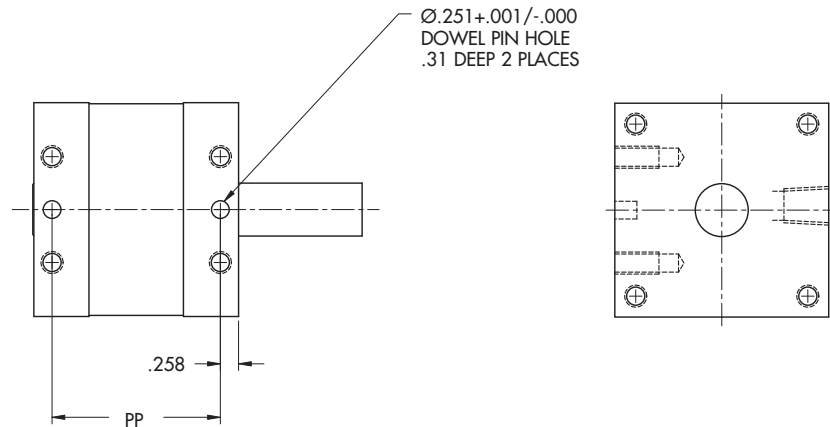

NOTE: Center drill omitted from shaft details for clarity.

BRUTE (BR) Series

Brute Models	PP
22X	2.624
23X	4.374
24X	6.874
25X	9.894
26X	12.894

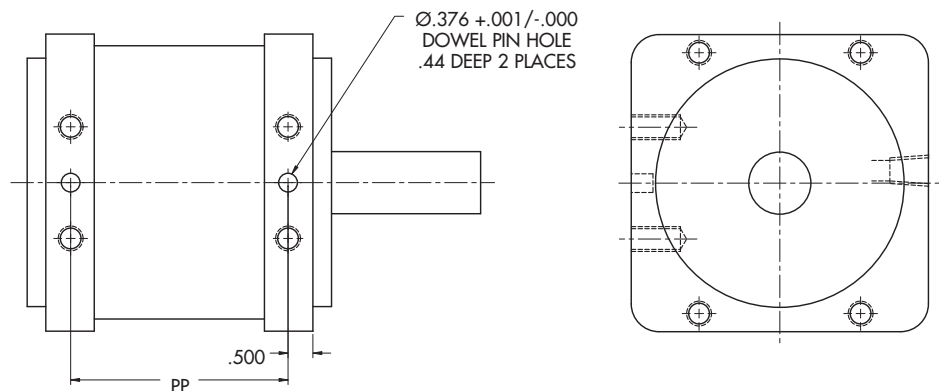

NOTE: Center drill omitted from shaft details for clarity.

Options- Three Hole Face Mount

Option #	Description
830	Three Hole Face Mount

NOTE: Not available in Brute series

TAP #10-32 UNF .38 DP
3 PLCS EQUALLY
SPACED ON Ø1.28 B.C.

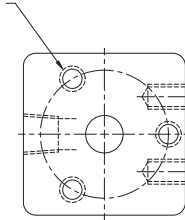

COMP-ACT (CA) Series

TAP 5/16-18 UNC .50 DP
3 PLCS EQUALLY
SPACED ON Ø2.44 B.C.

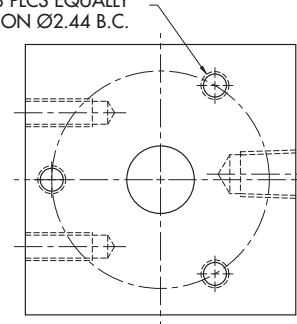

TURN-ACT (TA) Series

Options- Low Profile Actuators

This option provides shorter overall length when available space will not permit the use of standard product. The standard End Caps and Needle Bearings are replaced with "Thinner" End Caps and PTFE Bearing Surfaces. This option requires smaller than standard air inlets. The Low Profile option reduces the side load rating of the actuator to 50lbs. in the Comp-Act Series and 100lbs. in the Turn-Act Series. This option is not available on the Brute Series.



COMP-ACT SERIES ACTUATOR WITH LOW PROFILE HEADS AND TEFLON IMPREGNATED ANODIZING (OPTION 704) WITH SHAFT TURNED DOWN

How to Order	Description
Under the "End Cap" Selection section of the "How to Order" Comp-Act or Turn-Act Series Models – Select #2	Low Profile Actuators

NOTE:
1. Low Profile Heads reduce the side load rating of the actuator. Not available in Brute series.

COMP-ACT (CA) Series

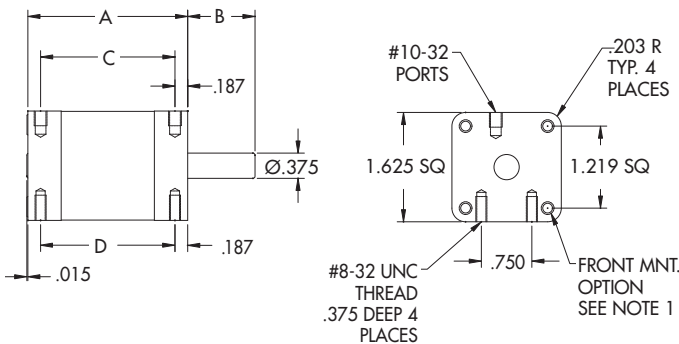

TURN-ACT (TA) Series

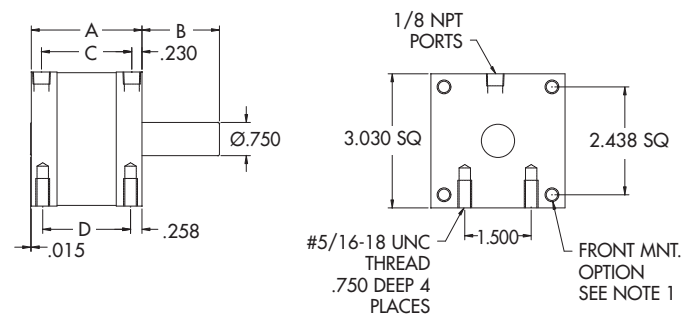

NOTE:
1. Only available with Extended Tie Rods or Combination Flange options. Consult Factory.

Comp-Act Models	A	B	C	D
01X	1.375	1.000	1.000	1.000
02X	1.875	1.000	1.500	1.500
03X	2.375	1.000	2.000	2.000
04X	2.875	1.000	2.500	2.500
06X	4.425	1.000	4.050	4.050

Turn-Act Models	A	B	C	D
11X	2.500	1.750	2.040	1.984
12X	4.000	1.750	3.540	3.484
13X	4.020	1.750	6.560	6.504
14X	9.980	1.750	9.520	9.464

Options- Adjustable Stroke Control (ASC)

The Adjustable Stroke Control (ASC) option allows an actuator to be adjusted to the exact rotational stroke desired. The "ASC" option consists of a shaft mounted steel cam, enclosed in a housing with control screws (see method of operation below). Turning the control screws either extends or limits the amount of rotation. The ends of the control screws impact the cam providing a positive and repeatable end of rotation stop. The ASC option is often specified for applications where the stroke required is not within the rotational tolerance. The standard rotational stroke tolerance of an actuator is $+4^{\circ}/-0^{\circ}$. (i.e.: A 90-degree actuator without ASC will have a rotation of $90^{\circ}-94^{\circ}$ with the addition of the ASC option a precise 90° rotation is attainable.)

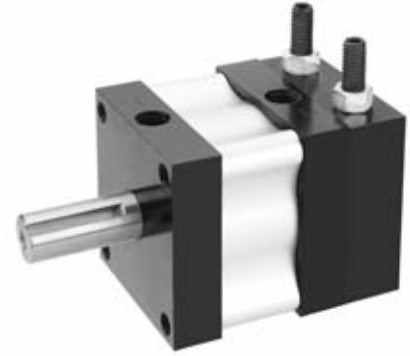

Option #	Description
400	ASC Cap End, Position 5
401	ASC Rod End, Position 1
402	ASC Cap End, Position 6*
403	ASC Rod End, Position 2*
404	ASC Cap End, Position 7
405	ASC Rod End, Position 3
406	ASC Cap End, Position 8*
407	ASC Rod End, Position 4*

* Bottom mnt. pattern changes to side mnt. dimensions (see pg. 18) on ASC end only - Brute Series

NOTE:

1. Contact Factory for other adjusting ranges.
2. The Thrust Protection Option (see pg. 22) can be integrated into the ASC Housing to minimize the overall length of the actuator.

Actuator Rotation	Adjusting Range
*45°	0-45 degrees
90°	0-90 degrees
**110°	0-110 degrees
180°	90-180 degrees
270°	90-270 degrees
**290°	90-290 degrees

* Turn-Act Series Only

** Brute Series Only

NOTE: Rotations greater than 180° are not fully adjustable with a standard 2 screw adjustable stroke control. Consult factory for greater adjustment range.

Adjustable Stroke Control (ASC) Dimension				
MODEL/Series	(A =max) in.	(B) in.	(C) in. Sq.	(D) in.
Comp-Act (CA)	1.500	0.656	1.63	.130
Turn-Act (TA)	3.250	1.000	3.00	.200
Brute (BR)	6.500	1.500	5.98	N/A

POSITION REFERENCE DRAWING

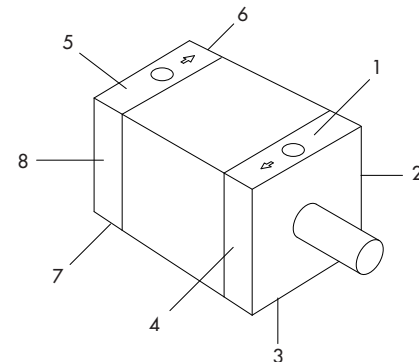

NOTE: Specify the position to be tapped for adjustment screws. Example: Option 407 would call out position 4 as the adjustment screw location, as depicted in the drawing above.

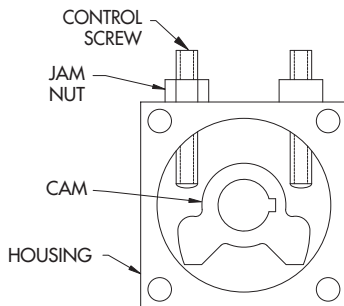

METHOD OF OPERATION

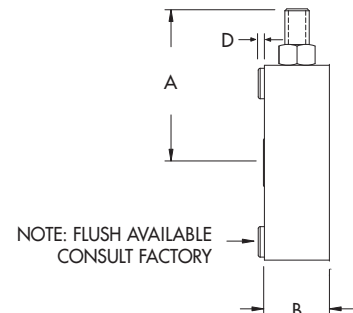
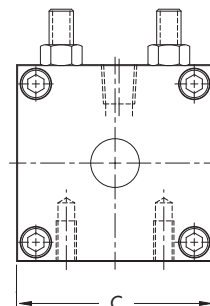

NOTE: FLUSH AVAILABLE
CONSULT FACTORY

DIMENSIONAL DATA

Options-Thrust Protection

Standard Turn-Act Rotary actuators are designed to accommodate high side (radial) loads and relatively light end (thrust) loads. Excessive thrust load will cause premature seal wear and shorten actuator cycle life. (See chart below.) Applications that produce high linear/thrust loads, such as when the shaft is vertical, with the load set on or hanging from the shaft may require the Thrust Protection option.

This option consists of a series of internal thrust bearings and a shaft collar enclosed in a machined aluminum housing. This system effectively isolates the load from the actuator vane, permitting higher thrust load limits. (See chart.)

NOTE: The Adjustable Stroke Control (ASC) Option can be integrated into the Thrust Protection Housing to minimize the overall length of the actuator (See pg 21).



TURN-ACT SERIES ACTUATOR WITH OPTIONAL THRUST PROTECTION AND TEFLON IMPREGNATED ANODIZING

Option #	Position
900	Cap End
901	Rod End

Series	Load Limit Without Thrust Protection	Load Limit With Thrust Protection	(A) IN. SQ.	(B) IN.
Comp-Act (CA)	10 LBS	250 LBS	1.62	.656
Turn-Act (TA)	25 LBS	500 L	3.03	1.000
Brute (BR)	1000 LBS	CONSULT FACTORY		

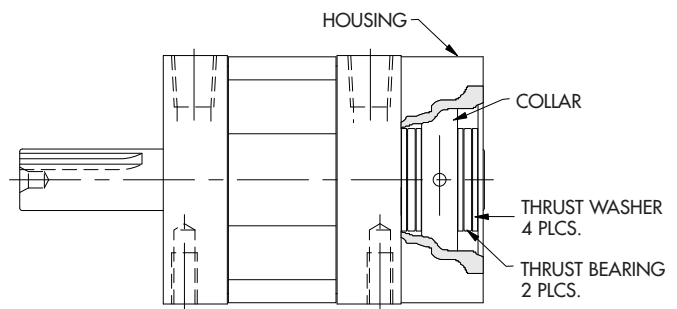
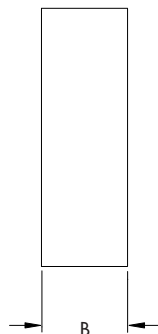
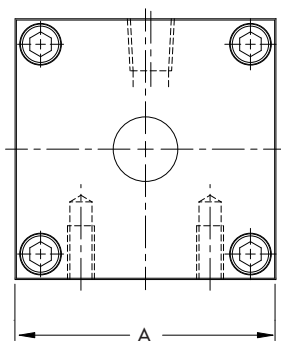

Options- Internal Rotation Stop

Turn-Act rotary actuators are available with nominal 45, 90, 110, 180, 270 and 290 degree rotations. Adjustable stroke control frequently fills the requirement for other than nominal rotations. Some applications have the additional requirement of preventing any user adjustability.

To fill these requirements of:

- A specific non-standard rotation
- User non-adjustability

The Internal Rotation Stop option is accomplished through the use of an extrusion that is bonded to the inner diameter of the rotary actuator tube. This extrusion is machined to restrict the rotation of the actuator. This option can be used to enhance the response time of an actuator by consuming the excess volume of the rotary actuator.

NOTE: A rotation tolerance of +4/-0 degrees is standard, closer tolerance is available. Consult Factory.

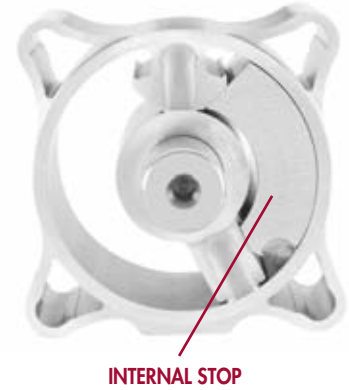

INTERNAL STOP

Options- Urethane Bumpers

Polyurethane BUMPERS absorb kinetic energy and reduces noise at the end of stroke. Actual rotation and repeatability achieved when bumpers are installed will be dependent on Load... Air Pressure... and Speed of Rotation.

Series	Option #
Comp-Act (CA)	B00
Turn-Act (TA)	B00
Brute (BR)*	B00

NOTE: Only 1 end of rotation can be bumpered when the 45-degree rotor is ordered.
* 180° Brute Units (B99)

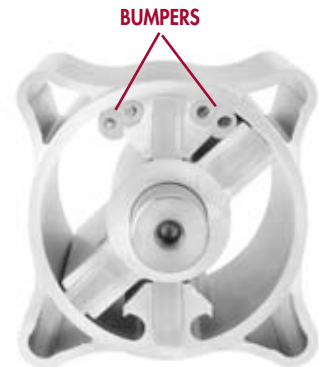

BUMPERS

Options- Motion Control Package

Flow controls are frequently used to affect the speed of rotary and linear actuators. However, in some applications, such as over-center rotary loads, flow controls do not adequately check the speed of rotation. In these types of applications the TURN-ACT Motion Control option can provide effective speed control.

The TURN-ACT Motion Control package is available on the Comp-Act, Turn-Act and Brute Series of rotary vane actuators.

The system consists of 2 linked yet independent rotary actuators, which share a common shaft. (See photo.) The "Rod End" actuator moves the load. The "Control" actuator is oil filled and controls the speed of actuation. A needle valve meters the flow of the fluid through the control actuator. This option provides a uniform, controlled speed of the actuator throughout its rotation.

This integral Motion Control Package provides a smooth controlled actuation while eliminating the need for external Air/Oil systems.

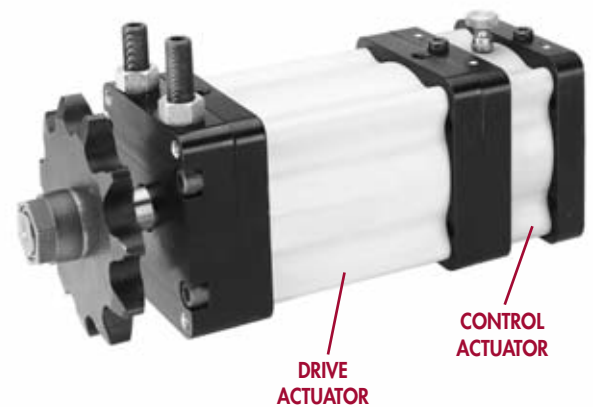

BRUTE SERIES ACTUATOR WITH OPTIONAL ADJUSTABLE STROKE CONTROL AND MOTION CONTROL.

Consult factory for application information.

Options- Cap Switch Systems

Turn-Act Rotary Vane Actuators are available with electronic position sensing switches. The switches have LED lamps that light when in sensing position. If adjusted for end of stroke indication, the LED will remain lit as long as the stroke position is maintained. A small shaft mounted magnet in the switch housing operates the switches (See drawings).



SWITCH SYSTEM WITH 8MM QUICK DISCONNECT



SWITCH SYSTEM WITH 9 FT. LEADS

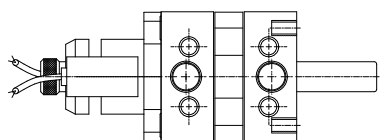
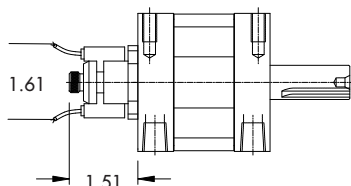

COMP-ACT (CA) SERIES SWITCHES

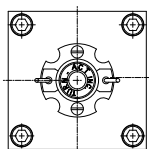

TURN-ACT (TA) SERIES SWITCHES

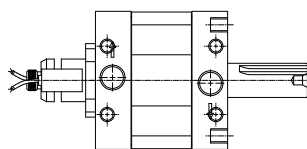

BRUTE (BR) SERIES SWITCHES

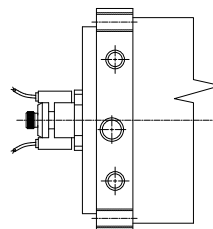

SWITCH PACKAGE (CAP END)							
Includes a Cap End Mounted Switch Ready Housing							
Option #*	Switch Type	Function	Lead Type	Switching Voltage	Switching Current	Switching Power	Max. Voltage Drop
A00	Switch Ready No Switches						
A05	PNP/Sourcing	Normally Open Output	22 gauge	6-24 VDC	0.5 Amp Max	N/A	0.5 Volts
A08	NPN/Sinking	Normally Open Output	22 gauge	6-24 VDC	0.5 Amp Max	N/A	0.5 Volts
A02	AC/DC Reed	SPST Normally Open	22 gauge	5-120 VDC/VAC 50/60 Hz	0.5 Amp Max 0.005 Amp min.	10 watts Max	3.5 Volts
A25	PNP/Sourcing	Normally Open Output	8mm Type - B QD	6-24VDC	0.5 Amp Max	N/A	0.5 Volts
A28	NPN/Sinking	Normally Open Output	8mm Type - B QD	6-24VDC	0.5 Amp Max	N/A	0.5 Volts
A22	AC/DC Reed	SPST Normally Open	8mm Type - B QD	5-120 VDC/VAC 50/60 Hz	0.5 Amp Max 0.005 Amp min.	10 watts Max	3.5 Volts

*Caution: Switches will be permanently damaged if operated without a load. Consult factory if lead length will exceed 20 feet.

Options- Disk Switch Systems

Turn-Act Rotary Vane Actuators are available with the DISK Switch System. It is designed for use with double end actuators or when the available space will not permit the use of other switch options. The Disk Switch System includes a shaft extension to accommodate a shaft-mounted magnet disk. The switches are mounted in dovetail grooves located to sense the disk-mounted magnet (Actuator shown with thrust protection option).

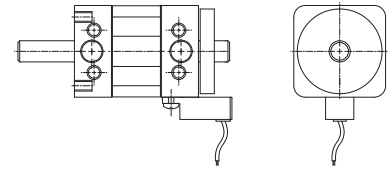

COMP-ACT (CA) DISK SWITCHES



COMP-ACT DISK SWITCH

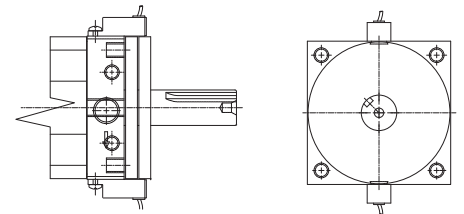

TURN-ACT (TA) DISK SWITCH

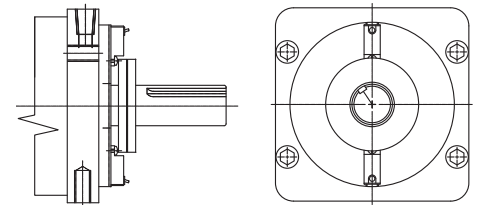

BRUTE (BR) DISK SWITCH

Typical Disk Switch configurations: Consult factory for precise dimensions.

DISK SWITCH (CAP END)							
Includes 2 Each <u>Rear</u> Mounted Magnet Disks and Dove-Tail Grooves on the Cap Ends to Accept Switches							
Option #*	Switch Type	Function	Lead Type	Switching Voltage	Switching Current	Switching Power	Max. Voltage Drop
Consult Factory	Switch Ready No Switches						
Consult Factory	PNP/Sourcing	Normally Open Output	22 gauge	6-24 VDC Max	0.5 Amp	N/A	0.5 Volts
Consult Factory	NPN/Sinking	Normally Open Output	22 gauge	6-24 VDC Max	0.5 Amp	N/A	0.5 Volts
Consult Factory	AC/DC Reed	SPST Normally Open	22 gauge	5-120 VDC.VAC 50/60 Hz	0.5 Amp Max 0.005 Amp min.	10 watts Max	3.5 Volts
Consult Factory	PNP/Sourcing	Normally Open Output	8mm Type - B QD	6-24VDC	0.5 Amp Max	N/A	0.5 Volts
Consult Factory	NPN/Sinking	Normally Open Output	8mm Type - B QD	6-24VDC	0.5 Amp Max	N/A	0.5 Volts
Consult Factory	AC/DC Reed	SPST Normally Open	8mm Type - B QD	5-120 VDC/VAC 50/60 Hz	0.5 Amp Max 0.005 Amp min.	10 watts Max	3.5 Volts

*See Page 27 for wiring diagrams.

Options- Disk Switch Systems

DISK SWITCHES (1 SWITCH EACH END)

Includes 1 Each Front and 1 Each Rear Mounted Magnet Disks and Dove-Tail Grooves on the Rod and Cap Ends to Accept Switches

Option #*	Switch Type	Function	Lead Type	Switching Voltage	Switching Current	Switching Power	Max. Voltage Drop
Consult Factory	Switch Ready No Switches						
Consult Factory	PNP/Sourcing	Normally Open Output	22 gauge	6-24 VDC Max	0.5 Amp	N/A	0.5 Volts
Consult Factory	NPN/Sinking	Normally Open Output	22 gauge	6-24 VDC Max	0.5 Amp	N/A	0.5 Volts
Consult Factory	AC/DC Reed	SPST Normally Open	22 gauge	5-120 VDC/VAC 50/60 Hz	0.5 Amp Max 0.005 Amp min.	10 watts Max	3.5 Volts
Consult Factory	PNP/Sourcing	Normally Open Output	8mm Type - B QD	6-24VDC	0.5 Amp Max	N/A	0.5 Volts
Consult Factory	NPN/Sinking	Normally Open Output	8mm Type - B QD	6-24VDC	0.5 Amp Max	N/A	0.5 Volts
Consult Factory	AC/DC Reed	SPST Normally Open	8mm Type - B QD	5-120 VDC/VAC 50/60 Hz	0.5 Amp Max 0.005 Amp min.	10 watts Max	3.5 Volts

*See Page 27 for wiring diagrams.

DISK SWITCH (ROD END)

Includes 2 Each Rod End Mounted Magnet Disks and Dove-Tail Grooves on the Rod End to Accept Switches

Option #*	Switch Type	Function	Lead Type	Switching Voltage	Switching Current	Switching Power	Max. Voltage Drop
Consult Factory	Switch Ready No Switches						
Consult Factory	PNP/Sourcing	Normally Open Output	22 gauge	6-24 VDC Max	0.5 Amp	N/A	0.5 Volts
Consult Factory	NPN/Sinking	Normally Open Output	22 gauge	6-24 VDC Max	0.5 Amp	N/A	0.5 Volts
Consult Factory	AC/DC Reed	SPST Normally Open	22 gauge	5-120 VDC.VAC 50/60 Hz	0.5 Amp Max 0.005 Amp min.	10 watts Max	3.5 Volts
Consult Factory	PNP/Sourcing	Normally Open Output	8mm Type - B QD	6-24VDC	0.5 Amp Max	N/A	0.5 Volts
Consult Factory	NPN/Sinking	Normally Open Output	8mm Type - B QD	6-24VDC	0.5 Amp Max	N/A	0.5 Volts
Consult Factory	AC/DC Reed	SPST Normally Open	8mm Type - B QD	5-120 VDC.VAC 50/60 Hz	0.5 Amp Max 0.005 Amp min.	10 watts Max	3.5 Volts

*See Page 27 for wiring diagrams.

Options- Switches: Wiring Diagrams

WIRE LEADS

NPN/PNP Switch with LED

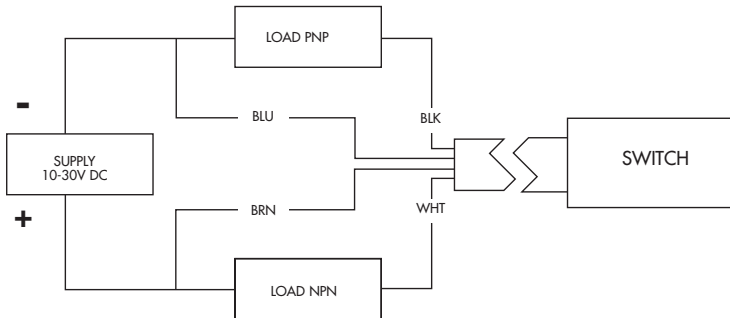

LEAD LENGTHS

- Wire Leads – 9'
- Quick Disconnect: Pigtail – 6"
- Cordset – 15'

AC/DC Reed Switch MOV* with LED

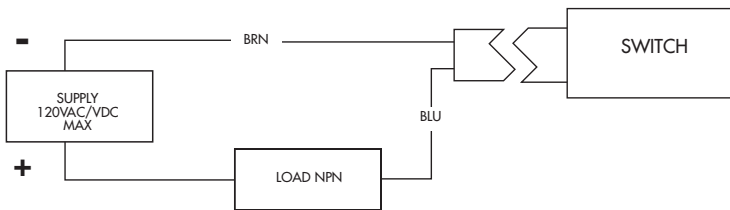

CAUTION: TO AVOID PERMANENT DAMAGE TO SWITCHES

- 1 Do not exceed rated voltage
- 2 Observe power supply polarity
- 3 Do not operate without a load
- 4 Do not short circuit the load
- 5 Consult factory if lead length will exceed 20 ft.

*NOTE: Power supply polarity need not be observed in AC applications.

QUICK DISCONNECT TYPE – B

PNP Sourcing Switch with LED and Type - B Quick Disconnect

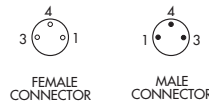
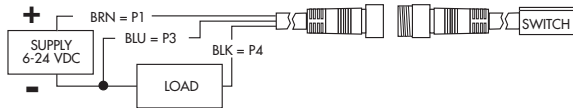

ROTATIONAL LIMITS

Any rotational limits (including Adjustable Stroke Control settings) must be made prior to adjusting switches. Changes in rotation will require the switches to be re-adjusted.

NPN Sinking Switch with LED and Type - B Quick Disconnect

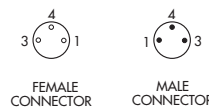
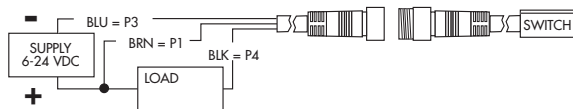

AC/DC Reed Switch MOV* with LED and Type - B Quick Disconnect

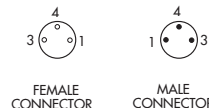
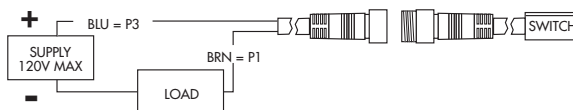

*NOTE: Power supply polarity need not be observed in AC applications.
Metal oxide varistor surge suppression.

ALLEN-BRADLEY PLC's

With I/O module #1791 require reed switches with internal current limiting protection. This feature is now standard.

Options- Electrical Position Indication (EPI)

The EPI switch system consists of a steel cam that rotates with the actuator vane. This assembly is enclosed in a housing. The housing is tapped to accept a threaded body switch (GO® Switches). When threaded into the EPI housing, the switch senses the cam as it approaches the end of stroke.



TURN-ACT FULL STAINLESS STEEL BODY ACTUATOR AND OPTION 500

How to Order Electrical Position Indication (EPI)	
(EPI) Option #	Description: Includes housing, ferrous cam with or without switches as specified below.
500	EPI Cap End, Position 5 – 2 D279 switches included
501	EPI Rod End, Position 1 – 2 D279 switches included
520	EPI Cap End, Position 5 – without switches
521	EPI Cap End, Position 1 – without switches

The maximum adjusting range is limited to 15° each end of rotation.

POSITION REFERENCE DRAWING

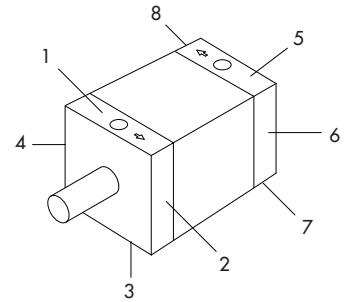

NOTE: Specify the position to be tapped for adjustment screws.
Example: Option 500 would call out position 5 as the prox. switch location, as depicted in the photo above.

Part #	Switch Type/Manufacturer	Operation	Contacts	Housing
D279	GO/Topworx®	SPDT Magnetic Proximity	240VAC 2 Amp 24VDC 50ma	303/304 Stainless Steel Threads 5/8" -18 Environmentally Sealed

NOTE: The same system can be adapted for other brands of threaded body switches. The (EPI) Electrical Position Indication is available by option number only on the Turn-Act and Brute Series, for the Comp-Act Series see the Prox Switch Ready option (pg 29).

GO® Switches reg. General Equipment Co.

Consult factory for application information.

Options- Proximity Switch Ready (PSR)

This option is similar to the EPI/Electrical Position Indicator. (See photo pg. 28.) The "Prox Switch Ready" System consists of a shaft mounted ferrous target cam, enclosed in a housing that is tapped to accept your choice of threaded body switch. Comp-Act, Turn-Act, and Brute Actuators are available as "Prox Switch Ready". (Does Not Include Switches.)

Option #		Description
530	8mm	PSR Cap End, Position 5
540	4mm	PSR Cap End, Position 5
570**	12mm	PSR Cap End, Position 5
571**	12mm	PSR Rod End, Position 1
590*	18mm	PSR Cap End, Position 5
591*	18mm	PSR Rod End, Position 1
420	5/16-24	PSR Cap End, Position 5
421	5/16-24	PSR Rod End, Position 1
430**	3/8-24	PSR Cap End, Position 5
431**	3/8-24	PSR Rod End, Position 1
440*	1/2-20	PSR Cap End, Position 5
441*	1/2-20	PSR Rod End, Position 1

* Brute (BR) series only. Consult factory for Comp-Act and Turn-Act.

** Not available on Comp-Act (CA).

Note: Extreme care needs to be taken when adjusting the switch to insure that the cam does not contact the switch body during actuation. Catastrophic switch failure may occur if the cam contacts the switch body. Do Not Use as an Adjustable Stroke Control. The Adjustable Stroke Control Option (ASC) should be ordered additionally, if the rotation required is outside the standard range and tolerance $\pm 4/-0$ degrees. (See page 21.) Consult Factory for required minimum probe lengths.



TURN-ACT ACTUATOR WITH PROXIMITY SWITCH READY OPTION

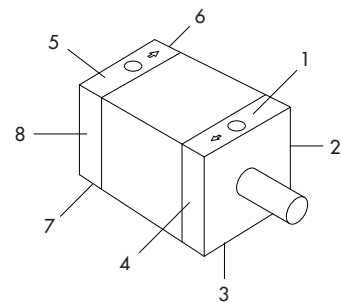

POSITION REFERENCE DRAWING

NOTE: Specify the position to be tapped for prox. switches. Example: Option 530 would call out position 5 as the prox. switch location, as depicted in the drawing above.

Potentiometers and Encoders

Provides continuous Position sensing loop control systems. (See Drawings.)

Customer selected Potentiometers and Encoders can be mounted/adapted to any of Turn-Act's Rotary Vane Actuators for use in closed loop control systems. (See drawings.)

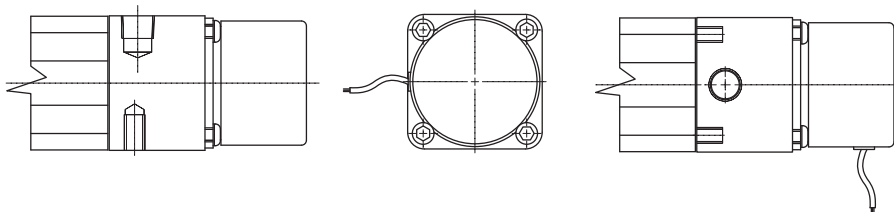

TYPICAL METHOD OF OPERATION ENCLOSED ENCODER MOUNTED TO A TURN-ACT VANE ACTUATOR

Consult factory for application information.



TURN-ACT ACTUATOR WITH ENCODER

Options- Port Locations/Port Types

Below is a partial listing of the inlet/port modifications available.

- Standard port location – Available Port Types and Locations.
- Combination Rod Head and Flange with optional port location
- Double Ports – order to increase actuator response time.
- End Ports – permits access to both ports on the cap head end.

Contact the factory for other options.

STANDARD PORT SIZES

Comp-Act Series	Turn-Act Series	Brute Series
1/8 NPT	1/4 NPT	3/8 NPT

AVAILABLE PORT SIZES

Comp-Act Series	Turn-Act Series	Brute Series
	Option# G10	
10-32	1/8 NPT	1/4 NPT



TURN-ACT ACTUATOR AND OPTIONAL END PORTS

Options- Namur Mount

The Namur Mount is a standard connection pattern for mounting a control valve directly to an actuator. This is a working standard for the process control industry. It permits interchangeability between control valve manufacturers.

The pattern consists of:

- 2 drilled orifices to correspond to the valve ports.
- 4 Mounting/Locating holes, which will allow variable valve orientation.

NOTE: Turn-Act does not supply the control valve.



TURN-ACT ACTUATOR WITH (OPTION EN1) NAMUR MOUNTED CONTROL VALVE



TURN-ACT ACTUATOR AND OPTIONAL NAMUR MOUNT (OPTION EN1)

Turn-Act Model	X	Y
11X	2.38	3.34
12X	4.04	4.99
13X	7.07	8.02
14X	10.02	10.98

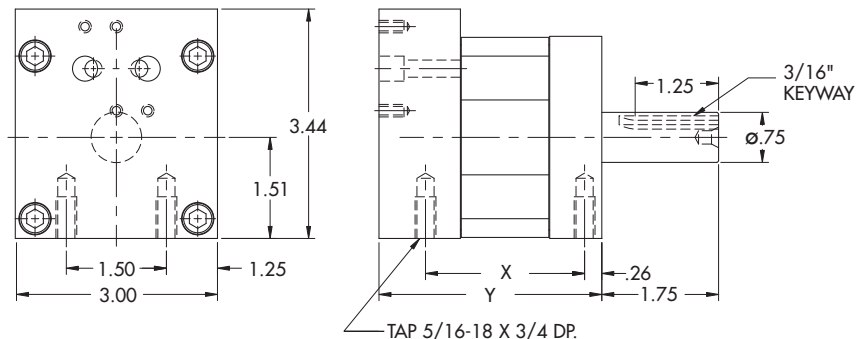

NAMUR REAR MOUNT DRAWING

Consult factory based on various manufacturing of namur products.

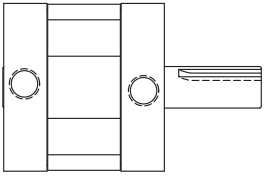

SINGLE KEYWAY

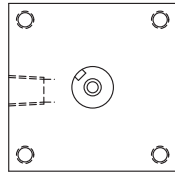

NEED a **MODIFIED**

SHORTER...

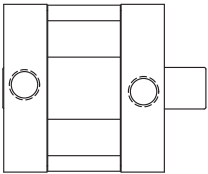

SINGLE END SHORT SHAFT

LONGER...

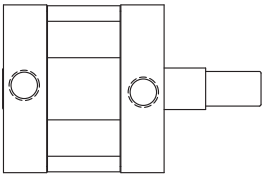

TURNED DOWN

TURNED DOWN...

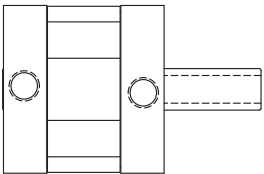

GUN DRILL

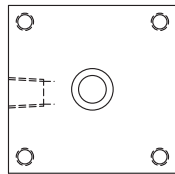

GUN DRILLED...

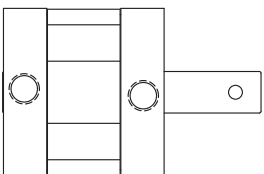

CROSS DRILL HOLE

CROSS DRILLED...

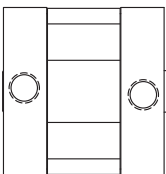

SINGLE END LONG SHAFT

SHAFT...

ANSWER ENGINEERING -

The willingness and ability to modify Turn-Act rotary and linear product to fit a specific application.

RAPID CUSTOM MODIFICATION.

Most of our sales are special orders, so we're prepared to be flexible, responsive and accurate. Modifications can be as simple as a shaft extension or an entirely new product. Most often these modifications go from concept to shipped product faster than the competition ships a standard. Our commitment to Answer Engineering is just a phone call away.

RESPONSIVE to your challenge.

Responsiveness is what Answer Engineering is all about. It's why 60% of our business is custom. You bring us a challenge, and through technical innovation we'll find an answer. Simply put, if you can imagine it, we can make it happen.

CHALLENGE US.

We're confident we can respond to your application needs.

ETC... ETC... ETC...

NOT A PROBLEM. IT'S WHAT WE CALL ANSWER ENGINEERING.

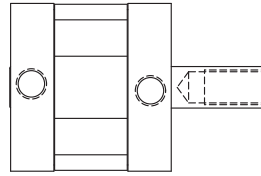

END OF SHAFT TAP

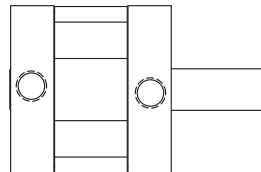

NO KEYWAY

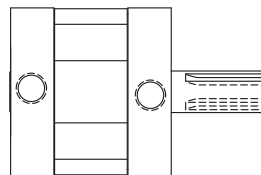

DOUBLE KEYWAY

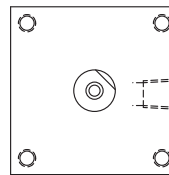

SET SCREW FLAT

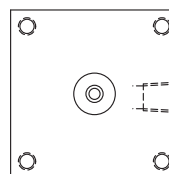

DOUBLE END

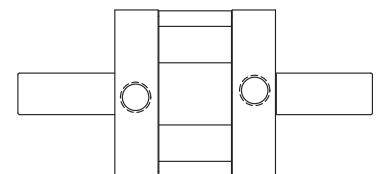
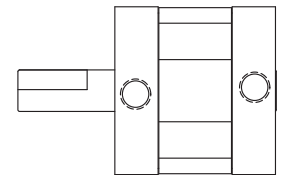

Options- Shaft Accessories- Trantorque®

Trantorque

Trantorque keyless shaft couplings eliminates:

- The need for keys, keyways and setscrews.
- Simplifies synchronization.
- Allows for infinite radial adjustments.
- Mounts hubless devices.

The Trantorque coupling uses 2 opposing tapers that expand into the OD and contract on the ID to attach and hold shaft loads.

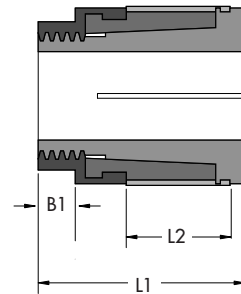
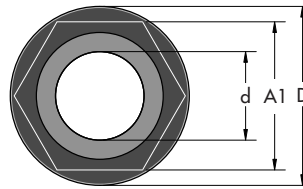

NON-TRAVERSING

Style	Trantorque Series		Part #	Actuator Shaft Diameter (d)	Component Bore (D)	Max. Transmissible		Dimensions					
						Tq.	Thrust	L1	L2	A1	A2	B1	B2
Non-Traversing	Imperial Mini	Comp-Act Series 1-1/4" Bore OEM	6980109	3/8"	3/4"	175 in. lbs.	648 lbs.	1-3/16"	7/16"	5/8"	NA	1/8"	N/A
	Imperial Series	1-1/4" Bore Turn-Dex	6980120	5/8"	1-1/2"	1225 in. lbs.	2310 lbs.	1-21/32"	11/16"	1-1/4"	1-1/2"	5/16"	5/16"
		Turn-Act Series 2-1/2" Bore OEM	6980160	3/4"	1-1/2"	1750 in. lbs.	3080 lbs.	1-21/32"	11/16"	1-1/4"	1-1/2"	5/16"	5/16"
		2-1/2" Bore Turn-Dex	6980240	1"	1-3/4"	2450 in. lbs.	4620 lbs.	2-1/32"	13/16"	1-1/2"	1-3/4"	7/16"	3/8"
		Brute Series	6980320	1-1/4"	2"	4200 in. lbs.	5950 lbs.	2-13/32"	15/16"	1-3/4"	2"	1/2"	9/16"

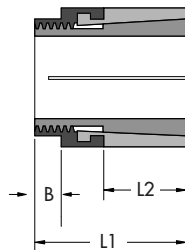
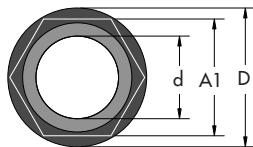

MINI SERIES

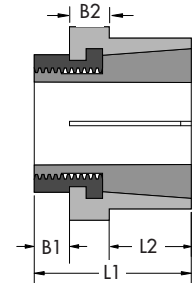
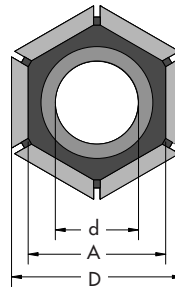

GT SERIES

Style	Trantorque Series		Standard Part #	Stainless Steel Part #	Actuator Shaft Diameter (d)	Component Bore (D)	Standard Unit Max. Transmissible		Stainless Units Max. Transmissible		Dimensions					
							Tq.	Thrust	Tq.	Thrust	L1	L2	A1	A2	B1	B2
Standard or Stainless	Imperial Mini	Comp-Act Series 1-1/4" Bore OEM	6202109	6990109	3/8"	3/4"	250 in. lbs.	925 lbs.	75 lbs.	280 lbs.	7/8"	7/16"	5/8"	N/A	1/8"	N/A
	Imperial Series	1-1/4" Bore Turn-Dex	6202120	6990112	5/8"	1-1/2"	1750 in. lbs.	3300 lbs.	525 in. lbs.	990 1-1/2"	1-1/2"	3/4"	1-1/4"	1-1/2"	5/16"	5/16"
		Turn-Act Series 2-1/2" Bore OEM	6202160	6990160	3/4"	1-1/2"	2500 in. lbs.	4400 lbs.	750 in. lbs.	1320 lbs.	1-1/2"	3/4"	1-1/4"	1-1/2"	5/16"	5/16"
		2-1/2" Bore Turn-Dex	6202240	6990240	1"	1-3/4"	3500 in. lbs.	6600 lbs.	1050 in. lbs.	1980 lbs.	1-7/8"	7/8"	1-1/2"	1-3/4"	7/16"	3/8"
		Brute Series	6202320	6990320	1-1/4"	2"	6000 in. lbs.	8500 lbs.	1800 in. lbs.	2550 lbs.	2-1/4"	1"	1-3/4"	2"	1/2"	9/16"
Metric	Metric Mini	Comp-Act Series 1-1/4" Bore OEM	620268	Consult Factory	8 mm	19 mm	23 N-m	4.0 Kn	Consult Factory		22 mm	11 mm	16 mm	N/A	3 mm	N/A
	Metric GT Series	Turn-Act Series 2-1/2" Bore OEM	6202770		17 mm	38 mm	220 N-m	17 Kn			38 mm	19 mm	32 mm	38,1 mm	8 mm	8 mm
		Brute Series	6202835		30 mm	51 mm	580 N-m	35.4 Kn			57 mm	25,5 mm	46 mm	50,8 mm	13 mm	14,5 mm

Shaft Accessories-Trantorque (cont.)

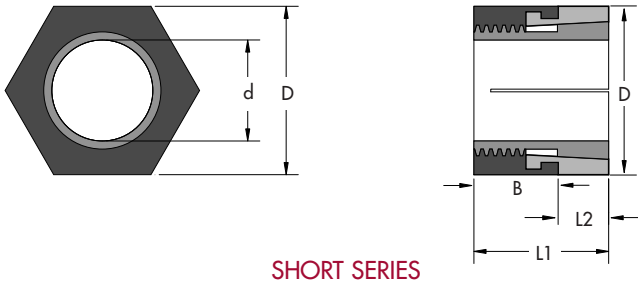

SHORT SERIES

Style	Trantorque Series		Part #	Actuator Shaft Diameter (d)	Component Bore (D)	Max. Transmissible		Dimensions			
						Tq.	Thrust	L1	L2	A	B
Short Series	Imperial Mini	Comp-Act Series 1-1/4" Bore OEM	6940109	3/8"	3/4"	250 in. lbs.	925 lbs.	5/8"	1/4"	3/4"	3/8"
		1-1/4" Bore Turn-Dex	6940120	5/8"	1-1/2"	1750 in. lbs.	3300 lbs.	1-1/4"	1/2"	1-1/2"	3/4"
	Imperial Series	Turn-Act Series 2-1/2" Bore OEM	6940160	3/4"	1-1/2"	2500 in. lbs.	4400 lbs.	1-1/4"	1/2"	1-1/2"	3/4"
		2-1/2" Bore Turn-Dex	6940240	1"	1-3/4"	3500 in. lbs.	6600 lbs.	1-1/4"	1/2"	1-1/4"	3/4"
		Brute Series	6940320	1-1/4"	2"	6000 in. lbs.	8500 lbs.	1-1/4"	1/2"	2"	3/4"

Options- Shaft Accessories- Hub Adapter

This option provides an alternative to the conventional output shaft. The Hub Adapter option allows for easy mounting of grippers, tooling, actuators, cylinders and other end effectors that require a flat mounting surface.

The Hub is manufactured of aluminum with 4 counter bored through holes on one side and threaded holes on other. Trantorque (see Trantorque section) is used in mounting of the Hub Adapter to the actuator shaft. This attachment method provides infinite hub/hole orientation.

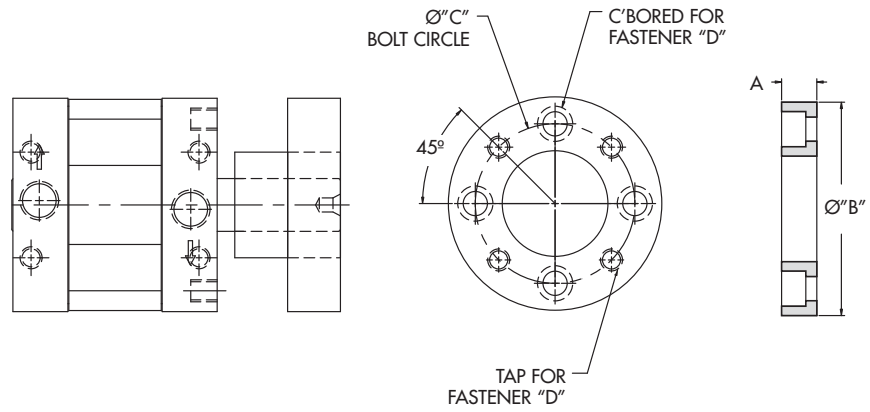

TRANTORQUE WITH ADAPTER HUB

Option #	Description
M10	W/Mild Steel Trantorque
M20	W/Stainless Steel Trantorque

Hub Adapter Dimensions	Comp-Act (CA) Series	Turn-Act (TA) Series	Brute Series
A	0.438"	0.750"	1.000"
B	1.563"	2.500"	5.000"
C	1.156"	2.000"	3.656"
D	#10-24	1/4-20	1/2-13

NOTE: Contact Factory for other hub diameters, bolt hole patterns, etc.

3 Position Actuator Systems

The Turn-Act Three Position Actuator System utilizes a control actuator, output actuator, and a set of stop cams to achieve the desired rotation.

The two actuators (control & output) are mounted on a common plate. The single end control actuator (see drawing) is located at the back of the assembly. The double end output actuator is located at the front of the assembly. Stop cams are mounted on the rear shaft of the output actuator and the front shaft of the control actuator. These cams allow the control actuator to restrict the motion of the output actuator by rotating a stop into an interference mid-stroke position. When the control actuator rotates the stop cam out of the interference position the output actuator is free to rotate to its end of stroke. Adjustable stroke control permits precise mid and end of stroke positioning. Unlike other 3 position systems, the TURN-ACT system has ZERO backlash and is 100% repeatable in all stop positions.

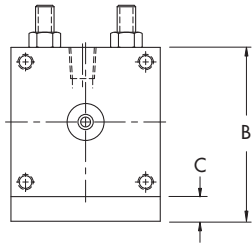

COMP-ACT (CA) 3 POSITION SYSTEM

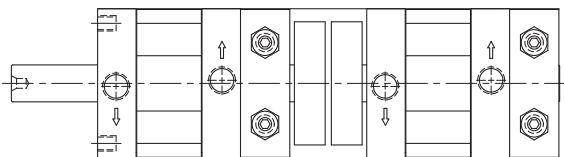

3 POSITION SYSTEM CAMS

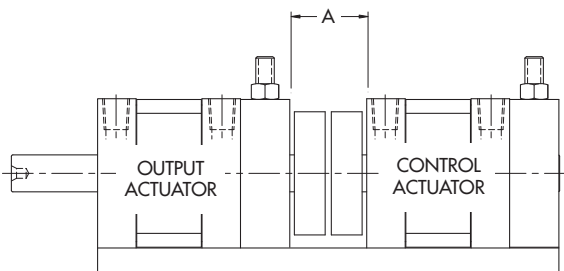

TYPICAL 3 POSITION SYSTEM

Consult factory for application needs.

Model	A	B	C
CA	1.040	2.000	.375
TA	1.562	3.530	.500
BR	5.750	6.750	.750

NOTE: Overall length of the 3 Position System is determined by adding the (A) to the combined length of the actuators selected.



TURN-ACT (TA) 3 POSITION SYSTEM

Hydraulic Service Rotary Actuators

Turn-Act Rotary Actuators can be ordered with modifications for use only in **low-pressure, non-shock** hydraulic applications.

Hydraulic pressure shock is a common phenomenon of hydraulic systems, and is the most common cause of actuator failure. The actuator must be isolated from this shock or damage may occur. Proper hydraulic system design is a requirement for Hydraulic Service Rotary Actuators, and must include pressure-reducing valves for each actuator in use, in addition to normal system pressure relief valves.

Consult factory for the required modifications for hydraulic applications. This option includes:

- Head drain ports
- Modified rotor assembly
- Modified seal configuration
- Heat treated/hardened shaft

Hydraulic Service Rotary Actuators are available in the Comp-Act and Turn-Act series. The allowable pressures are listed below:

Comp-Act 200 psi for all sizes

Turn-Act 500 psi for size 1 & 2

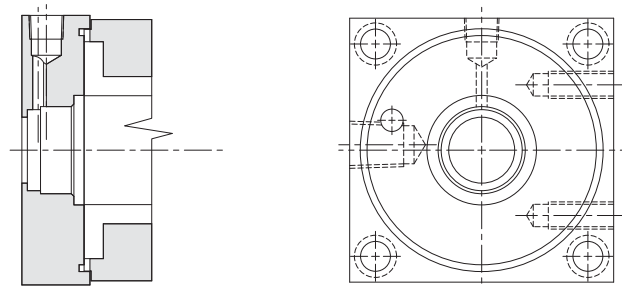
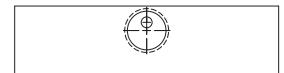
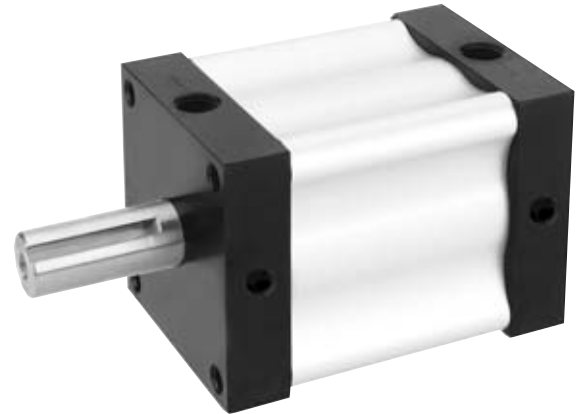

HYDRAULIC DRAIN PORT DETAIL

Actuators for Special Environments

As standard Turn-Act Actuators are designed for most industrial environments. However food service, clean room, (medical and semi conductor) and other environments where the units will be subjected to frequent wash down, often with caustic solutions may require special modification.

Modifications available are:

- Shaft quad seals in lieu of standard "o" rings
- Viton seals
- Stainless steel shaft and fasteners
- Blind cap heads
- Blind and sealed Adjustable Stroke Control

- Exterior coatings:
 - Teflon impregnated hard anodized surface meets FDA & USDA requirements for use in caustic and clean room environments.
 - Epoxy – consult factory for specific coating, cost and delivery
 - Nickel Plated – consult factory for cost and delivery
- Exterior Materials:
 - Full Stainless Steel (303 & 316) Body Actuators. The patented Turn-Act tube is produced in stainless steel to meet specific application requirements.

These modifications can be varied to address the specific needs of the application.

Consult the factory for specific ordering information.



TEFLON IMPREGNATED ANODIZING



EPOXY COATED



FULL STAINLESS STEEL BODY

Clean-Series Option

Turn-Act Rotary Vane Actuators offer distinct advantages over linear cylinders in clean room applications. Below is a comparison of design and operation issues of both cylinders and vane actuators. Also included is general information regarding how contaminants can be introduced into clean environments.

The Clean-Series option has been developed for use in environments that are contamination sensitive. Contamination can occur through multiple methods:

1. Introduction of contamination via cylinder external leakage.

Linear air cylinders have external sliding parts that may have slight air leakage from the piston rod. During extension and retraction the piston rod can introduce contaminants into the clean room by pulling lubricants out of the cylinder past rod seals and wipers. The lubrication required for these cylinders to perform properly is a primary source of contamination.

2. Contaminant Formation caused by abrasion.

Contaminants can be formed through abrasion of cylinder moving components during operation.

3. Components not properly degreased and packaged after manufacture.

Failure to properly clean and degrease components after assembly and test will introduce contamination. Additionally, packaging with improper materials can further result in introduction of contaminants into the clean environment.

Turn-Act Rotary Vane Actuator WITH the Clean Series Option addresses these contamination issues through:

1. Minimization of potential external leakage.

The design of Turn-Act Rotary Vane Actuators inherently minimizes the potential of external contamination from lubricants.

The shaft/rod of a vane actuator does not retract into, or extend out of the air chamber. In a Rotary Vane Actuator the rod rotates outside of the lubricated air cylinder. This results in a minimization of lubricant related contamination. Additional actuator modification can further reduce the incidence of contamination. A secondary, rod head, vacuum port, positioned between inner and outer rod-packings, permits the use of vacuum to exhaust potential contamination outside of the clean room.

2. Reduce abrasion contaminant formation.

Turn-Act's selection of non-contaminating anodized aluminum surfaces, Delrin® bearings, stainless steel shafting and alternative lubricants reduces the likelihood of contamination formation through the abrasive action during operation of the actuator.

3. Proper Cleaning and degreasing.

Turn-Act thoroughly de-greases and cleans actuators with non-contaminating compounds bagged and sealed for shipment in anti static packaging. This choice of materials for the cylinder surfaces, bearings and shafting further minimizes the introduction of contamination in clean rooms.

The nature of a rotary actuator, permits any tooling to be rotated in front of the work surface as opposed to linear cylinders where the rod is typically directed at the work surface. This design factor further minimizes the potential of external contamination being directed at the clean room work surfaces.

Proper Clean Room Design will contribute to the overall minimization of contamination. When possible, pneumatic components should be mounted below and as far from the work surface as practical.



**EØ1-CLEAN-SERIES ACTUATOR/
COMP-ACT (CA)**

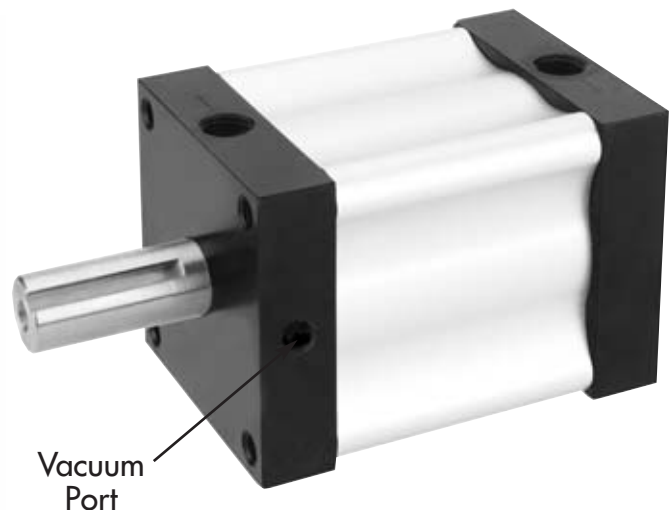

**SPECIAL-CLEAN-SERIES ACTUATOR/
TURN-ACT (TA)**

NOTE: Turn-Act Rotary Vane Actuators are suitable and compatible for most clean-room applications. For "Class I" and "Class X" applications please consult the factory.

Systems

Turn-Act Rotary Vane Actuators can be combined with other Turn-Act products to create multiple axis systems.

- Guided Rod Cylinder
- NFPA Cylinders
- Rotary Actuators
- Multi-Act

LINEAR SYSTEMS:

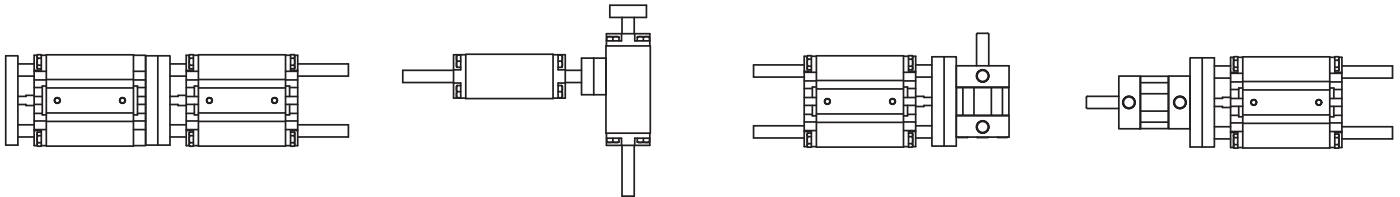

(A) INLINE LINEAR

(B) PERPENDICULAR LINEAR

(C) PERPENDICULAR ROTARY

(D) INLINE ROTARY

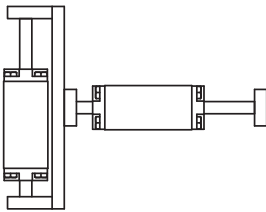

(E) WITH BRIDGEPLATE MOUNTED LINEAR

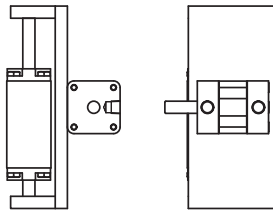

(F) WITH BRIDGEPLATE MOUNTED ROTARY

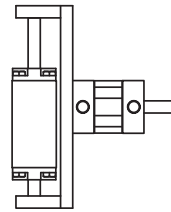

(G) WITH BRIDGEPLATE MOUNTED ROTARY

ROTARY SYSTEMS:

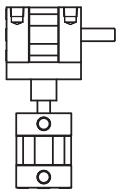

(H) PERPENDICULAR ROTARY

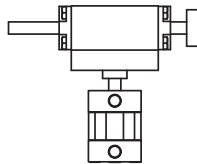

(I) PERPENDICULAR LINEAR

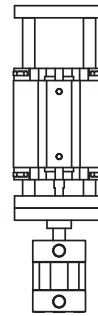

(J) INLINE LINEAR

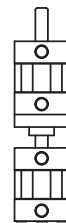

(K) INLINE ROTARY

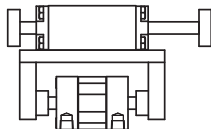

(L) WITH BRIDGEPLATE MOUNTED LINEAR

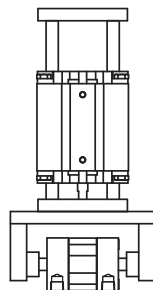

(M) WITH BRIDGEPLATE MOUNTED LINEAR

Consult factory for application information.

Turn-Dex 1-1/4" Bore

ROTARY VANE ACTUATORS

with integral unidirectional clutch:

- 6 base models with torque outputs from 13 in. lbs. to 60 in. lbs.
- Clockwise or Counterclockwise stepped rotations.
- Adjustable Stroke Control is standard.

Turn-Dex Stepper Indexer:

- Highly repeatable (+/- 1/2 degree).
- Provide instantaneous and continuous full torque.
- Produce more torque in less space.
- Eliminates gears and pivot points that wear, break or strip.
- Patented Urethane seals for:
 - Long cycle life and Non-lube service.
 - Actual applications with 25 million cycles and more.
- 100s of standard options and modifications.

Just imagine... How Answer Engineering can work for you!



TURN-DEX ACTUATOR WITH ADJUSTABLE STROKE CONTROL (STD) SHOWN WITH OPTION 801 (SIDE MOUNTS POS. 2 & 6)

Torque Chart (IN LBS.)			
180° and 270° Rotations ²			
Actuator Model	Actuator Torque at		
	100 PSI	80 PSI	60 PSI
321	13	10	7
323			
341	32	25	19
343			

Torque Chart (IN LBS.)			
90° Rotations ²			
Actuator Model	Actuator Torque at		
	100 PSI	80 PSI	60 PSI
322	25	20	15
342	60	48	36

SPECIFICATIONS

Unit Materials

Stator/Rotor Seals ...Urethane
 Shaft/Tube SealsBuna¹
 Shaft.....1144 G&P Steel
 Body.....Anodized Alum.
 Bearings.....Full Comp. Needle

Miscellaneous

Inlets.....1/8 NPT
 Min. Pressure35 psi
 Max. Pressure200 psi
 Cylinder Bore.....1-1/4"

Shaft Load Capacities

Max. Side Load125 lbs.
 Max. End Load.....10 lbs.

Temperature Range

-20°F to 180°F. Consult factory for higher temperature.

Filtration

Air 25-50 microns

Clutch

Type.....Roller, lock in one direction, free overrun in other direction.
 Max. Torque Rating...143 in. lbs.

Cycle Rates³

Max. non-lubed rate:
 Double Vane40 cpm
 Single Vane20 cpm
 Max. lubed rate:
 Consult Factory

Rotary Motion Backlash

All models.....0 degree

Leak Rates

Air 4 cfm or less@100 psi

1. Viton Optional
2. All rotations are nominal +4/-0 actual
3. Cycle = Start position to end of rotation and returning to the start position.
Stroke = 1/2 cycle

Capacity per Stroke ³ (IN ³)			
270° Rotation ²		90° Rotation ²	
321	0.99	322	0.84
341	1.99	342	1.68

Weights (OZs)			
270° Rotation ²		90° Rotation ²	
321	10	322	10
341	14	342	14

How to Order: Turn-Dex 1-1/4" Bore

DRIVE

MODEL DIRECTION OPTIONS OPTIONS

341 - 1 - A02 - XXX

1
2
3
3

1

Model			
Model	Bore	Torque	Rotation
321	1-1/4"	13	270
322	1-1/4"	25	90
323	1-1/4"	13	180
341	1-1/4"	32	270
342	1-1/4"	60	90
343	1-1/4"	32	180

2

Drive Direction	
Based on shaft end view and inlets at 12 O'Clock	
1	Clockwise
2	Counter-clockwise

3

Options	
Additional options available on pg. 9	
Option #	Description
000	No Options
100	Front Flange
101	Rear Flange
200	Side Angle Brackets, Mounting Surface 3 & 7
201	Side Angle Brackets, Mounting Surface 2 & 6
202	Side Angle Brackets, Mounting Surface 4 & 8
203	Side Angle Brackets, Mounting Surface 1 & 5
800	Side Mounts, Sides 1 & 5
801	Side Mounts, Sides 2 & 6
803	Side Mounts, Sides 4 & 8
804	Side Mounts, Sides 2, 4, 6 & 8
806	Side Mounts, Sides 6 & 8
807	Side Mounts, Sides 2 & 4
810	No Bottom Mounts
Cap Sensor Options (See pg. 13)	
A00	Sensor System – No Sensors
A05	Sensor System – 2 Sourcing Sensors
A08	Sensor System – 2 Sinking Sensors
A02	Sensor System – 2 Reed Sensors
A25	Sensor System – 2 Sourcing Sensors*
A28	Sensor System – 2 Sinking Sensors*
A22	Sensor System – 2 Reed Sensors*

*NOTE: See page 13 for Lead Type variation

Dimensional Data: Turn-Dex 1-1/4" Bore

Basic Dimensions

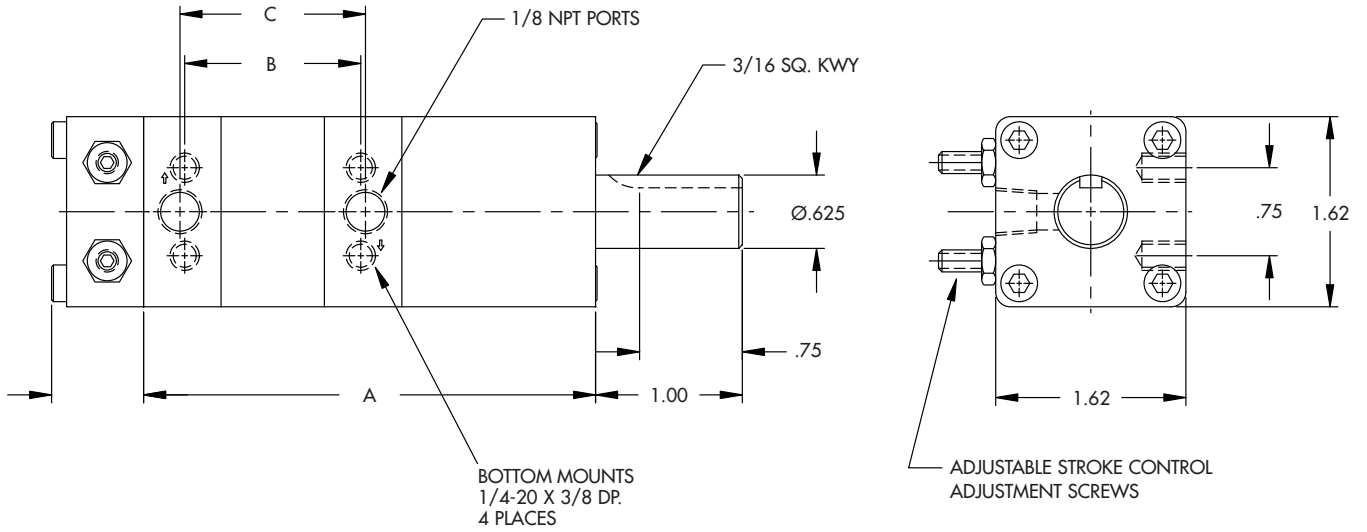

Dimensional Specifications			
Actuator	A	B	C
321	3.84	1.50	1.57
322	3.84	1.50	1.57
323	3.84	1.50	1.57
341	4.84	2.50	2.57
342	4.84	2.50	2.57
343	4.84	2.50	2.57

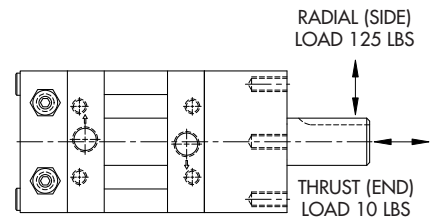
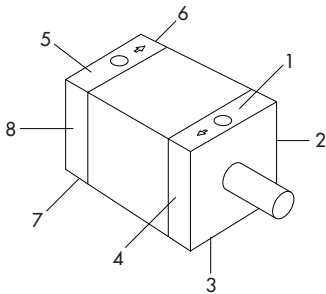

Port & Mounting Position References

Shaft Load Capacity

Turn-Dex 2-1/2" Bore

ROTARY VANE ACTUATORS

with integral unidirectional clutch:

- 10 base models with torque outputs from 87 in. lbs. to 350 in. lbs.
- Clockwise or Counterclockwise stepped rotations.
- Adjustable Stroke Control is standard.

Turn-Dex Stepper Indexer:

- Highly repeatable (+/- 1/2 degree).
- Provide instantaneous and continuous full torque.
- Produce more torque in less space.
- Eliminates gears and pivotpoints that wear, break or strip.
- Patented Urethane seals for:
 - Long cycle life and Non-lube service.
 - Actual applications with 25 million cycles and more.
- 100s of standard options and modifications.

Just imagine... How Answer Engineering can work for you!



TURN-DEX ACTUATOR WITH ADJUSTABLE STROKE CONTROL (STD)

Torque Chart (IN. LBS.)			
180° and 270° Rotations ²			
Actuator Model	Actuator Torque at		
	100 PSI	80 PSI	60 PSI
411	87	70	52
413			
421	175	140	105
423			
431	350	280	210
433			

Torque Chart (IN. LBS.)			
45° AND 90° Rotations ²			
Actuator Model	Actuator Torque at		
	100 PSI	80 PSI	60 PSI
412	175	140	105
414			
422	350	280	210
424			

SPECIFICATIONS

Unit Materials

Stator/Rotor Seals...Urethane
 Shaft/Tube Seals.....Buna¹
 Shaft1 1/4 G&P steel
 Body.....Anodized Alum.
 Bearings...Full Comp. Needle

Miscellaneous

Inlets.....1/4 NPT
 Min. Pressure35 psi
 Max. Pressure200 psi⁴
 Cylinder Bore2-1/2"

Shaft Load Capacities

Max. Side Load.....250 lbs.
 Max. End Load.....25 lbs.

Temperature Range

-20°F to 180°F. Consult factory for higher temperature.

Filtration

Air.....25-50 microns

Clutch

Type.....Roller, lock in one direction, free overrun in other direction
 Max. Torque Rating...412 in. lbs.

Cycle Rates³

Max. non-lubed rate:
 Double Vane40 cpm
 Single Vane20 cpm

Max. lubed rate:
 Consult Factory

Rotary Motion Backlash

All models0 degree

Leak Rates

Air.....4 cfm or less@100 psi

1. Viton Optional
2. All rotations are nominal +4/-0 actual
3. Cycle = Start position to end of rotation and returning to the start position. Stroke = 1/2 cycle
4. Pressure Rating for 41X and 42X is 500 psi max.

Capacity per Stroke ³ (IN ³)			
	270° Rotation ²		90° Rotation ²
411	4.52	412	2.75
421	8.50	422	5.50
431	17.0	N/A	N/A

Weights (LBS.)			
	270° Rotation ²		90° Rotation ²
411	2.5	412	2.5
421	3.3	422	3.5
431	6.0	N/A	N/A

How to Order: Turn-Dex 2-1/2" Bore

DRIVE
MODEL DIRECTION OPTIONS OPTIONS
413 - 2 - 200 - XXX
1 2 3 3

1

Model			
Model	Bore	Torque	Rotation
411	2-1/2"	87	270
412	2-1/2"	175	90
413	2-1/2"	87	180
414	2-1/2"	175	45
421	2-1/2"	175	270
422	2-1/2"	350	90
423	2-1/2"	175	180
424	2-1/2"	350	45
431	2-1/2"	350	270
433	2-1/2"	350	180

2

Drive Direction	
Based on shaft end view and inlets at 12 O'Clock	
1	Clockwise
2	Counter-clockwise

3

Options	
Additional options available on pg. 9	
Option #	Description
000	No Options
100	Front Flange
101	Rear Flange
200	Side Angle Brackets, Mounting Surface 3 & 7
201	Side Angle Brackets, Mounting Surface 2 & 6
202	Side Angle Brackets, Mounting Surface 4 & 8
203	Side Angle Brackets, Mounting Surface 1 & 5
800	Side Mounts, Sides 1 & 5
801	Side Mounts, Sides 2 & 6
803	Side Mounts, Sides 4 & 8
804	Side Mounts, Sides 2, 4, 6 & 8
806	Side Mounts, Sides 6 & 8
807	Side Mounts, Sides 2 & 4
810	No Side Mounts
900	Cap End
Cap Sensor Options (See pg. 13)	
A00	Sensor System – No Sensors
A05	Sensor System – 2 Sourcing Sensors
A08	Sensor System – 2 Sinking Sensors
A02	Sensor System – 2 Reed Sensors
A25	Sensor System – 2 Sourcing Sensors*
A28	Sensor System – 2 Sinking Sensors*
A22	Sensor System – 2 Reed Sensors*

*NOTE: See page 13 for Lead Type variation

Adjustable Stroke Control (ASC)

Standard on all Turn-Dex models, the Adjustable Stroke Control (ASC) allows an actuator to be adjusted to the exact rotational stroke desired. The ASC consists of a shaft mounted steel cam, enclosed in a housing with adjustment screws (see method of operation below). Turning the adjustment screws either extends or limits the amount of rotation. The ends of the adjustment screws impact the cam providing a positive and repeatable end of rotation stop. The ASC option is often specified for applications where the stroke required is not within the rotational tolerance. The standard rotational stroke tolerance of an actuator is $+4^\circ / -0^\circ$. (i.e.: A 90° actuator without ASC will have a rotation of 90° - 94° . With the addition of the ASC option a precise 90° rotation is attainable.)



Option #	Description
402	ASC Cap End, Position 6
404	ASC Cap End, Position 7
406	ASC Cap End, Position 8

NOTE: The Thrust Protection Option (see pg 12) is integrated into the ASC Housing.

Actuator Rotation	Adjusting Range
90°	0-90 degrees
180°	90-180 degrees
270°	90-270 degrees

NOTE: Rotations greater than 180° are not fully adjustable with a standard 2 screw adjustable stroke control. Consult factory for greater adjustment range.

Adjustable Stroke Control (ASC) Dimension				
MODEL/Bore	(A=max) in.	(B) in.	(C) in. Sq.	(D) in.
Turn-Dex 1-1/4"	1.500	0.656	1.63	.13"
Turn-Dex 2-1/2"	3.250	1.000	3.03	.10"

Position Reference Drawing

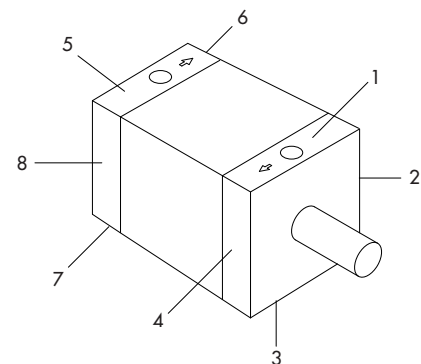

NOTE: Specify the position to be tapped for adjustment screws. Example: Option 407 would call out position 4 as the adjustment screw location, as depicted in the drawing above.

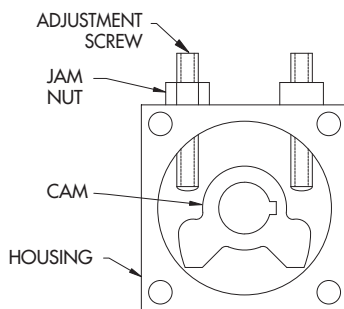

Method of Operation

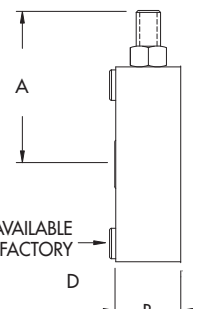
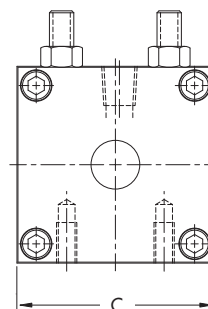

Dimensional Data

Turn-Dex Options – Flange Mount

Turn-Dex 1-1/4" Bore

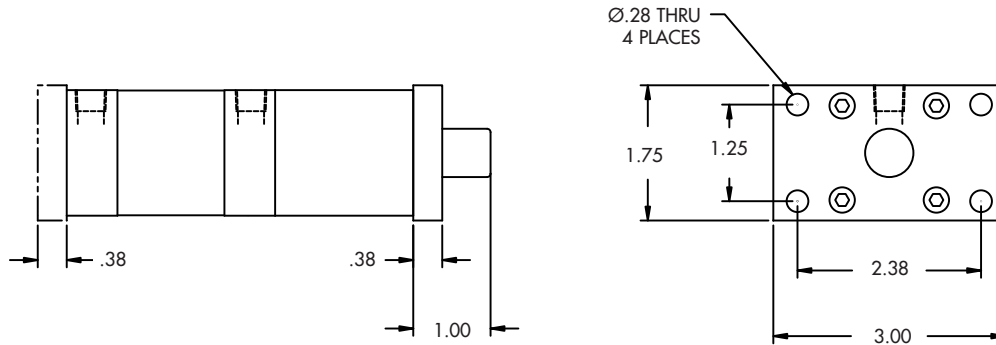

NOTE: ASC is standard on all Turn-Dex models but omitted for clarity.
Side Mounts surface 3 & 7 are standard, but are not shown for clarity.
Please refer to page 4 for dimensional information.

Turn-Dex 2-1/2" Bore

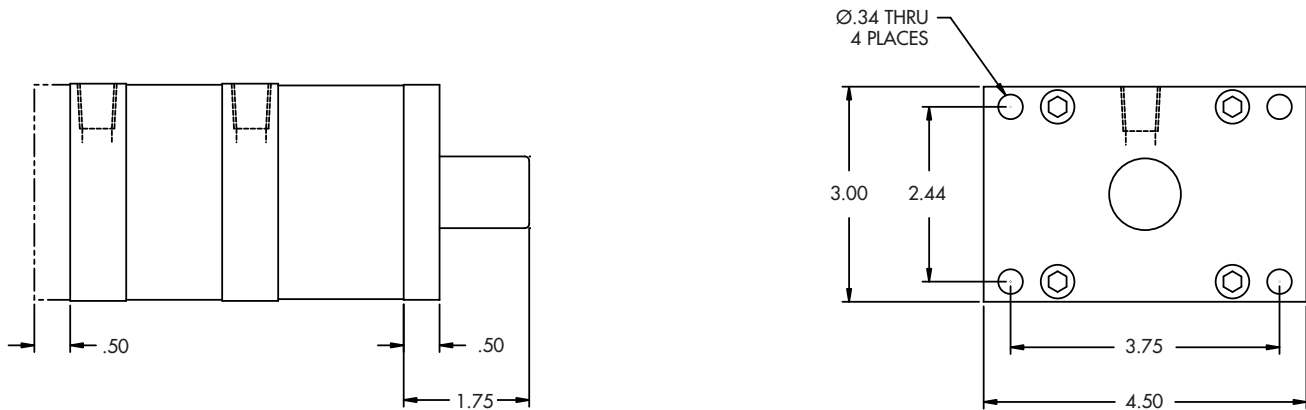

NOTE: ASC is standard on all Turn-Dex models but omitted for clarity.
Side Mounts surface 3 & 7 are standard, but are not shown for clarity.
Please refer to page 7 for dimensional information.

Option#	Description
100	Front Flange
101	Rear Flange

NOTE: The Flange Mount option and Adjustable Stroke Control option may not be ordered on the same end of a unit. Consult factory for additional flange options.

Turn-Dex Options - Side Angle Mounts

Option #	Description
200	Side Angle Brackets, Mounting Surface 3 & 7
201	Side Angle Brackets, Mounting Surface 2 & 6
202	Side Angle Brackets, Mounting Surface 4 & 8
203	Side Angle Brackets, Mounting Surface 1 & 5

NOTE: Specify the surface to be used for mounting. Example: Option 200 would call out surface 3 & 7 as the mounting surface, Option 201 would call out surface 2 & 6 as the mounting surface.

(2-1/2" Bore Only)

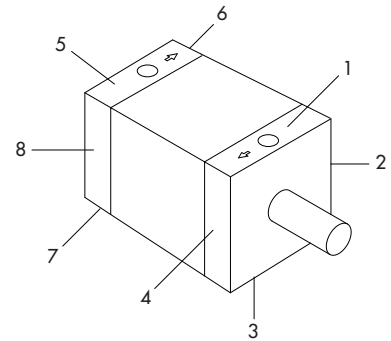

Mounting Surface Reference Drawing

Turn-Dex 2-1/2" Bore

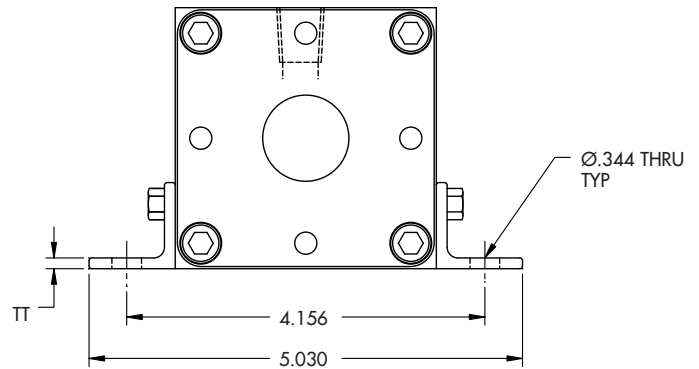
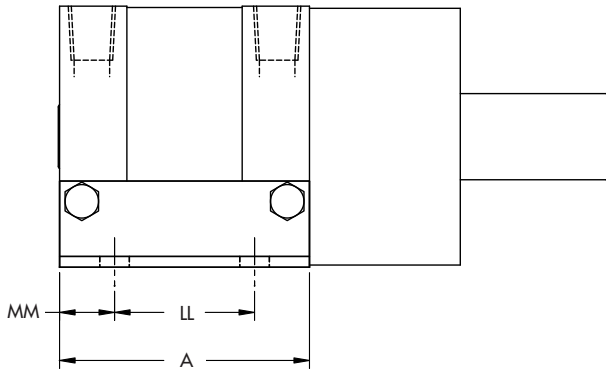

Option 200
Shown in Drawing

NOTE: ASC is standard on all Turn-Dex models but omitted for clarity. Please refer to page 7 for dimensional information.

Turn-Dex Model	A	LL	MM	TT
41X	2.90	1.625	.638	.125
42X	4.40	3.000	.694	.125
43X	7.42	6.000	.712	.119
44X	10.38	9.125	.626	.188

Turn-Dex Options - Side Mounts

Option #	Description
Side Mounts, Sides 3 & 7 Standard on all Mounts	
800	Side Mounts, Sides 1 & 5
801	Side Mounts, Sides 2 & 6
803	Side Mounts, Sides 4 & 8
804	Side Mounts, Sides 2, 4, 6 & 8
806	Side Mounts, Sides 6 & 8
807	Side Mounts, Sides 2 & 4
810	No Bottom Mounts

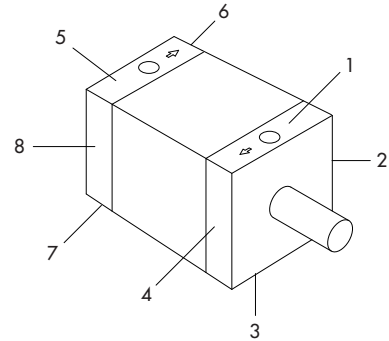

Position Reference Drawing

NOTE:

- Specify the side to be used for mounting. Example: Option 804 would call out sides 2, 4, 6 & 8 as the mounting surfaces, as depicted in the drawings below. Mount sides 3 & 7 are standard on all models but are not shown for clarity.
- ASC is standard on all Turn-Dex models but omitted for clarity. Please refer to page 8 for dimensional information.

Turn-Dex 1-1/4" Bore

Comp-Act Models	D
31X	1.00
32X	1.50
33X	2.00
34X	2.50
36X	4.05

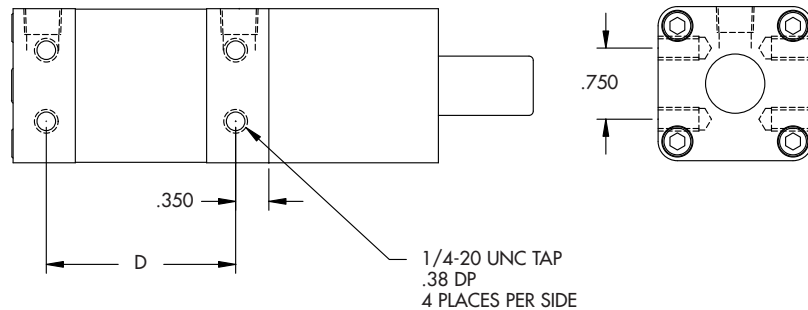

NOTE:

- Mounts surface 3 & 7 are standard, but are not shown for clarity. Standard Bottom Mount dimensions shown on page 4.
- ASC is standard on all Turn-Dex models but omitted for clarity. Please refer to page 8 for dimensional information.

Turn-Dex 2-1/2" Bore

Turn-Act Models	D
41X	2.38
42X	3.88
43X	6.91
44X	9.86

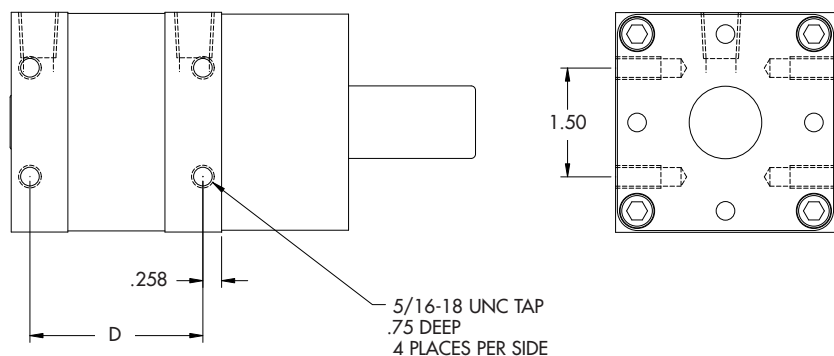

NOTE:

- Mounts surface 3 & 7 are standard, but are not shown for clarity. Standard Bottom Mount dimensions shown on page 7.
- Center drill omitted from shaft details for clarity.
- ASC is standard on all Turn-Dex models but omitted for clarity. Please refer to page 8 for dimensional information.

Turn-Dex Options - Thrust Protection

Excessive thrust load will cause premature seal wear and shorten actuator cycle life (See chart below). Applications that produce high linear/thrust loads, such as when the shaft is vertical, with the load set on or hanging from the shaft may require the Thrust Protection option.

This option consists of a series of internal thrust bearings and a shaft collar enclosed in a machined aluminum housing. This system effectively isolates the load from the actuator vane, permitting higher thrust load limits (See chart).



TURN-DEX SERIES ACTUATOR WITH OPTIONAL THRUST PROTECTION.

NOTE: The Adjustable Stroke Control (ASC) Option is integrated into the Thrust Protection Housing.

Option #	Position
901	Rod End

APPLICATION CONSIDERATIONS

Overrun:

The output shaft can be manually rotated only in its drive direction. Large loads may coast after the actuator has stopped. The output shaft cannot be reverse rotated. Forcing it backwards could damage the Turn-Dex.

Accurate & Repeatable Positioning:

Due to the overrun nature of the clutch, external stops, brakes, roller and detents or shot-pins are required for accurate and repeatable positioning.

Special Options:

Customized units to fit your specific application needs. Modifications include special shafting, special mounts, clutch housings with shot-pin cylinders, disc brakes and thrust protection. Consult factory for additional information.

Turn-Dex Options - Cap Sensor Systems

Turn-Dex Actuators are available with electronic position sensing sensors. The sensors have LED lamps that light when in sensing position. If adjusted for end of stroke indication, the LED will remain lit as long as the stroke position is maintained. A small shaft mounted magnet in the sensor housing operates the sensors (see drawings).



Sensor System with 8mm Quick Disconnect



Sensor System with 9 ft. Leads

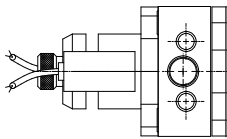

Turn-Dex 1-1/4" Bore Sensors

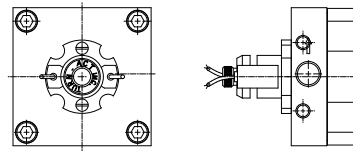
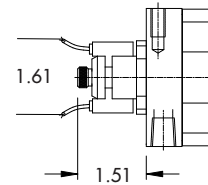

Turn-Dex 2-1/2" Bore Sensors

SENSOR PACKAGE (CAP END)							
Includes a <u>Cap End</u> Mounted Sensor Ready Housing							
Option #	Switch Type	Function	Lead Type	Sensing Voltage	Sensing Current	Sensing Power	Max. Voltage Drop
A00	Sensor Ready No Sensors	-	-	-	-	-	-
A05	PNP/Sourcing	Normally Open Output	22 gauge	6-24 VDC	0.5 Amp Max	N/A	0.5 Volts
A08	NPN/Sinking	Normally Open Output	22 gauge	6-24 VDC	0.5 Amp Max	N/A	0.5 Volts
A02	AC/DC Reed	SPST Normally Open	22 gauge	5-120 VDC/VAC 50/60 Hz	0.5 Amp Max 0.005 Amp min.	10 watts Max	3.5 Volts
A25	PNP/Sourcing	Normally Open Output	8mm Type - B QD	6-24VDC	0.5 Amp Max	N/A	0.5 Volts
A28	NPN/Sinking	Normally Open Output	8mm Type - B QD	6-24VDC	0.5 Amp Max	N/A	0.5 Volts
A22	AC/DC Reed	SPST Normally Open	8mm Type - B QD	5-120 VDC/VAC 50/60 Hz	0.5 Amp Max 0.005 Amp min.	10 watts Max	3.5 Volts

Caution: Sensors will be permanently damaged if operated without a load. Consult factory if lead length is lead length will exceed 20 ft.

NOTE: 2 sensors per option.

Turn-Dex Options - Trantorque®

Trantorque

Trantorque keyless shaft couplings eliminates:

- The need for keys, keyways and setscrews.
- Simplifies synchronization.
- Allows for infinite radial adjustments.
- Mounts hubless devices.

The Trantorque coupling uses 2 opposing tapers that expand into the OD and contract on the ID to attach and hold shaft loads.

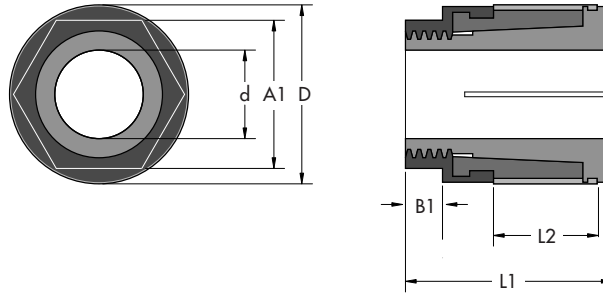

Non-Traversing

Style	Trantorque Series	Part #	Actuator Shaft Diameter (d)	Component Bore (D)	Max. Transmissible		Dimensions						
					Tq.	Thrust	L1	L2	A1	A2	B1	B2	
Non-Traversing	Imperial Series	Turn-Dex 1-1/4"	6980120	5/8"	1-1/2"	1225 in lbs.	2310 lbs.	1-21/32"	11/16"	1-1/4"	1-1/2"	5/16"	5/16"
		Turn-Dex 2-1/2"	6980240	1"	1-3/4"	2450 in lbs.	4620 lbs.	2-1/32"	13/16"	1-1/2"	1-3/4"	7/16"	3/8"

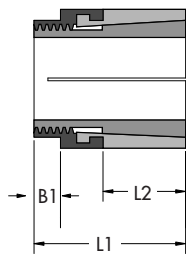
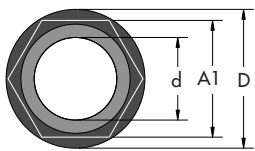

Mini series

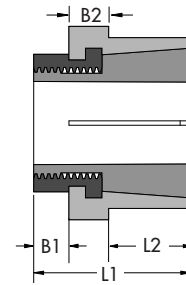
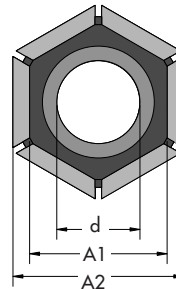

GT series

Style	Trantorque Series	Part #	Actuator Shaft Diameter (d)	Component Bore (D)	Max. Transmissible		Dimensions						
					Tq.	Thrust	L1	L2	A1	A2	B1	B2	
Standard Models	Imperial Series	Turn-Dex 1-1/4"	6980120	5/8"	1-1/2"	1750 in lbs.	3300 lbs.	1-1/2"	3/4"	1-1/4"	1-1/2"	5/16"	5/16"
		Turn-Dex 2-1/2"	6980240	1"	1-3/4"	3500 in lbs.	6600 lbs.	1-7/8"	7/8"	1-1/2"	1-3/4"	7/16"	3/8"

Style	Trantorque Series	Part #	Actuator Shaft Diameter (d)	Component Bore (D)	Max. Transmissible		Dimensions						
					Tq.	Thrust	L1	L2	A1	A2	B1	B2	
Stainless Models	Imperial Series	Turn-Dex 1-1/4"	6980120	5/8"	1-1/2"	525 in lbs.	990 lbs.	1-1/2"	3/4"	1-1/4"	1-1/2"	5/16"	5/16"
		Turn-Dex 2-1/2"	6980240	1"	1-3/4"	1050 in lbs.	1980 lbs.	1-7/8"	7/8"	1-1/2"	1-3/4"	7/16"	3/8"

Turn-Dex Options - Hub Adapter

This option provides an alternative to the conventional output shaft. The Hub Adapter option allows for easy mounting of grippers, tooling, actuators, cylinders and other end effectors that require a flat mounting surface.

The Hub is manufactured of aluminum with 4 counter bored through holes on one side and tapped holes on other. Trantorque (see Trantorque section) is used in mounting of the Hub Adapter to the actuator shaft. This attachment method provides infinite hub/hole orientation.

Option #	Description
M10	W/Carbon Steel Trantorque
M20	W/Stainless Steel Trantorque

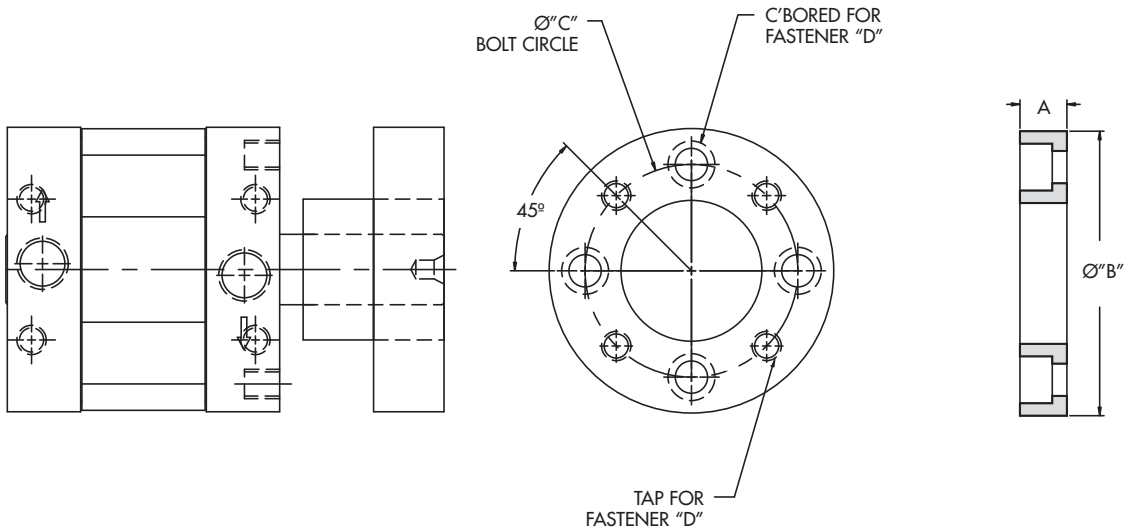

Trantorque with Hub Adapter

Hub Adapter Dimensions	Turn-Dex 1-1/4" Bore	Turn-Dex 2-1/2" Bore
A	0.438"	0.750"
B	1.563"	2.500"
C	1.156"	2.000"
D	#10-24	1/4-20

NOTE: Contact Factory for other hub diameters, bolt hole patterns, etc.

Specifications: Class-Act (CL) Valve Operator (1/4"-3/4")

Double Acting Valve Operator Systems

- Valve Sizes from 1/4" to 3/4"
- 48 in. lbs. to 80 in. lbs.

As compared to other rotary devices,
ITT Vane Actuators Have:

- One Moving Part Providing:
 - ZERO Backlash
 - No Loss of Motion
 - Smooth Rotation
 - Precise Repeatability
 - Continuous Full Torque Throughout Rotation
- ITT Patented Urethane Seals for:
 - Long Cycle Life and Non-Lube Service

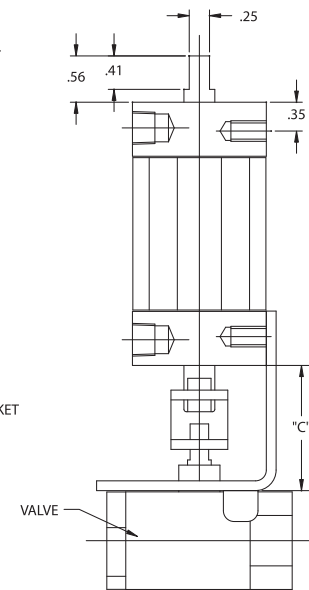
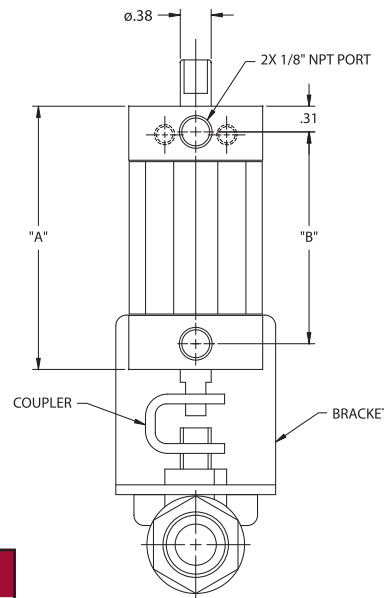
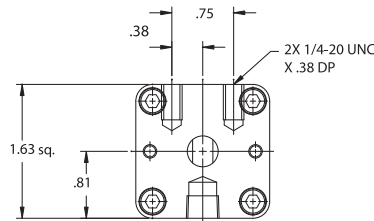

SPECIFICATIONS

Unit Materials

- Stator/Rotor Seals.....Urethane
- Shaft/Tube SealsBuna
- CylinderAnodized Alum.
- End CapsAnodized Alum.
- Shaft.....Stainless Steel
- TrimMild Steel, Opt'l S.S.
- BearingsDelrin
- Brackets.....Stainless Steel
- CouplingsStainless Steel

Miscellaneous

- Inlets.....1/8" NPT

Filtration

Air 25-30 microns

Temperature Range

-20°F to 180°F. Consult factory for higher temperature.

Torque Chart (in.lbs.)

Actuator Model	Actuator Torque at				
	40 PSI	60 PSI	80 PSI	100 PSI	150 PSI
742	21	35	48	60	90
762	35	58	80	100	150

Dimensions (in.)

Actuator Size	A	B
4	3.20	2.57
6	4.75	4.12

Capacity per Stroke

Actuator Model	Cubic Inches
742	1.66
762	2.52

Weight

Actuator Model	Pounds
742	0.88
762	1.13
Brackets	0.30

Dimensions (in.)

Valve Size	C
Apollo 1/4" thru 1/2"	1.57
Apollo 3/4"	1.73

How To Order: Class-Act (CL) Valve Operator (1/4" - 3/4")

Part Number Example: 742-501-BC-V1-E00

MODEL	END CAPS	SHAFT	UNIT MATERIAL	VALVE	BRACKET & COUPLING	OPTIONS	OPTIONS
742	5	O	1	BC	V1	E00	XXX
1	2	3	4	5	6	7	8

1

Model	
Operator - Torque (100 psi) - Rotation	
742	60 in. lbs. - 90°
762	100 in. lbs. - 90°

2

End Caps	
5	Pneumatic Clear Anodized

3

Shaft	
O	Double Manual Override

4

Unit Materials	
Shaft - Body - Trim	
1	303 Stainless Steel, Aluminum, Steel
3	303 Stainless Steel, Aluminum, Stainless Steel

5

Apollo Bronze Ball Valves ¹	
(Use '00' if not selecting a valve) Size - Type - Operator	
00	No Valve
BA	1/4" - 2 way - 4
BB	3/8" - 2 way - 4
BC	1/2" - 2 way - 4
BD	3/4" - 2 way - 6
BL	1/2" - Diverter - 6

5

Apollo Stainless Steel Ball Valves ²	
Valve Size - Type - Operator Size	
SA	1/4" - 2 way - 4
SB	3/8" - 2 way - 4
SC	1/2" - 2 way - 4
SD	3/4" - 2 way - 6
SL	1/2" - Diverter - 6

1 Bronze 2-way 1/4", 3/8" and 1/2" are Apollo Series 77 Full Port Ball Valve. The 3/4" is Apollo Series 71 Standard Port. Diverter Valves are Series 71. All Bronze valves have Stainless Steel Ball and Stem.

2 Stainless Steel 2-way and diverter valves are Apollo Series 76.

6

Bracket	
Valve Brand - Valve Size - Material	
00	No Bracket
V1	Apollo - 1/4", 3/8", 1/2" 304 Stainless Steel
V2	Apollo - 3/4", 1" 304 Stainless Steel

7

Options	
000	No Options
E00	Factory Assembled Operator Bracket, Coupling and Valve
400	Adjustable Stroke Control Cap End
704	Teflon Impregnated Hard Anodized

8

Switch Options	
All Axx Switch Options are Single End Only	
A00	Switch Ready - No Switches
A02	Switch Package ¹ - 2 Reed Switches
A05	Switch Package ² - 2 Sourcing Switches
A08	Switch Package ² - 2 Sinking Switches

1 Switch has built in protection for use with ABPLC

2 Switch function can be either sinking or sourcing depending on wiring scheme.

Consult Factory for Quick Disconnect Switches

Specifications: Val-U-Act (VA) Valve Operator (1/4" – 3")

Double Acting Valve Operator Systems

- Valve Sizes from 1/4" to 3"
- 140 in. lbs. to 560 in. lbs.

As compared to other rotary devices,
ITT Vane Actuators Have:

- One Moving Part Providing:
 - ZERO Backlash
 - No Loss of Motion
 - Smooth Rotation
 - Precise Repeatability
 - Continuous Full Torque Throughout Rotation
- ITT Patented Urethane Seals for:
 - Long Cycle Life and Non-Lube Service

SPECIFICATIONS

Unit Materials

Stator/Rotor SealsUrethane
 Shaft/Tube SealsBuna
 CylinderAnodized Alum.
 End CapsAnodized Alum.
 Shaft.....Mild Steel, Opt'l S.S.
 Trim.....Mild Steel, Opt'l S.S.
 BearingsDelrin
 Brackets.....Stainless Steel
 CouplingsStainless Steel

Miscellaneous

Inlets.....1/4" NPT

Filtration

Air 25-30 microns

Temperature Range

-20°F to 180°F. Consult factory for higher temperature.

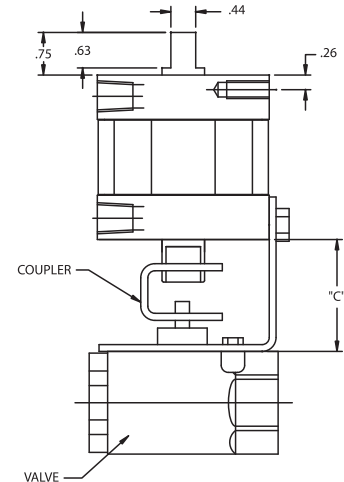
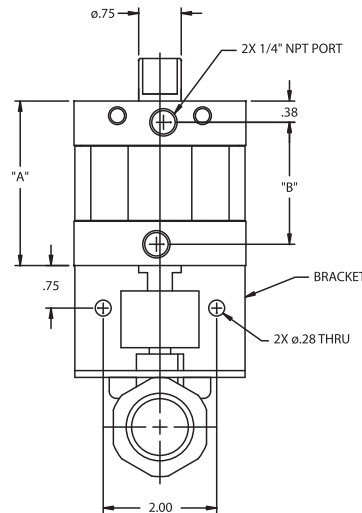
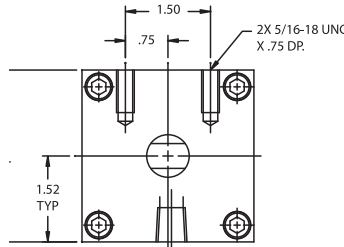

Torque Chart (in.lbs.)

Actuator Model	Actuator Torque at				
	40 PSI	60 PSI	80 PSI	100 PSI	150 PSI
812	70	105	140	175	265
822	140	210	280	350	524
832	280	420	560	700	1050

Dimensions (in.)

Actuator Size	A	B
1	2.90	2.15
2	4.40	3.64
3	7.42	6.67

Capacity per Stroke

Actuator Model	Cubic Inches
812	2.75
822	5.50
832	11.00

Weight

Actuator Model	Pounds
812	2.5
822	3.3
832	6.0
Brackets	0.2-0.8

Spring Return

Actuator Model	Add. Weight
822	3.0
832	9.0

Dimensions (in.)

Valve Size	C
Apollo 1/4" thru 1/2"	1.69
Apollo 3/4" thru 1"	1.97
Apollo 1 1/4" thru 2"	2.31
Apollo 2 1/2" thru 3"	2.25

How To Order: Val-U-Act (VA) Valve Operator (1/4" - 3")

Part Number Example: 812-501-BC-V1-E00

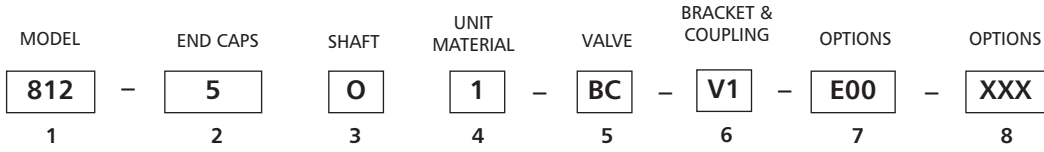

1 Model
Operator - Torque (100 psi) - Rotation

812	175 in. lbs. - 90°
822	350 in. lbs. - 90°
832	700 in. lbs. - 90°

2 End Caps

5	Pneumatic Clear Anodized
---	--------------------------

3 Shaft

O	Double Manual Override
---	------------------------

4 Unit Materials
Shaft - Body - Trim

1	Polished & Ground Fatigue Proof 1144 Steel - Anod. Alum. - Carb.Steel
3	303 Stainless Steel - Anod. Alum. - Stainless Steel

5 Apollo Bronze Ball Valves¹
(Use '00' if not selecting a valve)
Size - Type - Operator

00	No Valve		
BA	1/4"	- 2 way	- 1
BB	3/8"	- 2 way	- 1
BC	1/2"	- 2 way	- 1
BD	3/4"	- 2 way	- 1
BE	1"	- 2 way	- 1
BF	1 1/4"	- 2 way	- 2
BG	1 1/2"	- 2 way	- 2
BH	2"	- 2 way	- 2
BJ	3"	- 2 way	- 3
BL	1/2"	- Diverter	- 1
BM	3/4"	- Diverter	- 1
BN	1"	- Diverter	- 1
BO	1 1/4"	- Diverter	- 2
BP	1 1/2"	- Diverter	- 2
BQ	2"	- Diverter	- 2

Apollo Stainless Steel Ball Valves²
Valve Size - Type - Operator Size

SA	1/4"	- 2 way	- 1
SB	3/8"	- 2 way	- 1
SC	1/2"	- 2 way	- 1
SD	3/4"	- 2 way	- 1
SE	1"	- 2 way	- 1
SF	1 1/4"	- 2 way	- 2
SG	1 1/2"	- 2 way	- 2
SH	2"	- 2 way	- 2
SI	2 1/2"	- 2 way	- 3
SJ	3"	- 2 way	- 3
SL	1/2"	- Diverter	- 1
SM	3/4"	- Diverter	- 1
SN	1"	- Diverter	- 1
SP	1 1/2"	- Diverter	- 2
SQ	2"	- Diverter	- 2

¹ Bronze 2-way 1/4", 3/8" and 1/2" are Apollo Series 77 Full Port Ball Valve. 3/4" thru 3" are Apollo Series 71 Standard Port. Diverter Valves are Series 71. All Bronze valves have Stainless Steel Ball and Stem.

² Stainless Steel 2-way and diverter valves are Apollo Series 76.

6 Bracket
Valve Brand - Valve Size - Material

00	No Bracket
V1	Apollo - 1/4", 3/8", 1/2" 304 Stainless Steel
V2	Apollo - 3/4", 1" 304 Stainless Steel
V3	Apollo - 1 1/4", 1 1/2", 2" 304 Stainless Steel
V4	Apollo - 2 1/2", 3" 304 Stainless Steel

7 Options

000	No Options
E00	Factory Assembled Operator Bracket, Coupling and Valve
400	Adjustable Stroke Control Cap End
704	Teflon Impregnated Hardened Anodized

8 Switch Options
All Axx Switch Options are Single End Only

A00	Switch Ready - No Switches
A02	Switch Package ¹ - 2 Reed Switches
A05	Switch Package ² - 2 Sourcing Switches
A08	Switch Package ² - 2 Sinking Switches

¹ Switch has built in protection for use with ABPLC

² Switch function can be either sinking or sourcing depending on wiring scheme.

Consult Factory for Quick Disconnect Switches

How To Order: Val-U-Act Spring Return (VS) (1/4" - 3")

Part Number Example: 822-5A1-BC-V1-E00

MODEL	END CAPS	SHAFT	UNIT MATERIAL	VALVE	BRACKET & COUPLING	OPTIONS
822	5	A	1	BC	V1	E00
1	2	3	4	5	6	7

1 Model	
Operator - Torque (100 psi) - Rotation	
822	350 in. lbs. - 90°
832	700 in. lbs. - 90°

2 End Caps	
5	Pneumatic Clear Anodized

3 Shaft	
A	Spring Closes Valve
B	Spring Opens Valve

4 Unit Materials	
Shaft - Body - Trim	
1	Polished & Ground Fatigue Proof 1144 Steel - Anod. Alum. - Carb.Steel
3	303 Stainless Steel - Anod. Alum. - Stainless Steel

5 Apollo Bronze Ball Valves¹

(Use '00' if not selecting a valve)
Size - Type - Operator

00	No Valve	
BA	1/4" - 2 way	2
BB	3/8" - 2 way	2
BC	1/2" - 2 way	2
BD	3/4" - 2 way	2
BE	1" - 2 way	2
BF	1 1/4" - 2 way	3
BG	1 1/2" - 2 way	3
BH	2" - 2 way	3
BL	1/2" - Diverter	2
BM	3/4" - Diverter	2
BN	1" - Diverter	2
BO	1 1/4" - Diverter	3
BP	1 1/2" - Diverter	3
BQ	2" - Diverter	3

Apollo Stainless Steel Ball Valves²

Valve Size - Type - Operator Size

SA	1/4" - 2 way	2
SB	3/8" - 2 way	2
SC	1/2" - 2 way	2
SD	3/4" - 2 way	2
SE	1" - 2 way	2
SF	1 1/4" - 2 way	3
SG	1 1/2" - 2 way	3
SH	2" - 2 way	3
SL	1/2" - Diverter	2
SM	3/4" - Diverter	2
SN	1" - Diverter	2
SP	1 1/2" - Diverter	3
SQ	2" - Diverter	3

1 Bronze 2-way 1/4", 3/8" and 1/2" are Apollo Series 77 Full Port Ball Valve. 3/4" thru 3" are Apollo Series 71 Standard Port. Diverter Valves are Series 71. All Bronze valves have Stainless Steel Ball and Stem.

2 Stainless Steel 2-way and diverter valves are Apollo Series 76.

6 Bracket

Valve Brand - Valve Size - Material

00	No Bracket
V1	Apollo - 1/4", 3/8", 1/2" 304 Stainless Steel
V2	Apollo - 3/4", 1" 304 Stainless Steel
V3	Apollo - 1 1/4", 1 1/2", 2" 304 Stainless Steel
V4	Apollo - 2 1/2", 3" 304 Stainless Steel

7 Options

000	No Options
E00	Factory Assembled Operator Bracket, Coupling and Valve
400	Adjustable Stroke Control Cap End, Pos. 5
704	Teflon Impregnated Hard Anodized Note: Operator Only

Spring Return

Description:

Spring Return operators are formed bolting a spring return unit to a double acting Val-U-Act operator. The return movement is effected by a clock-type spring which is pretensioned to about half the operator torque. The amount of pretension is large, compared to the rotation and therefore the torque does not vary more than 20% over the rotation.

Spring returns are factory-installed and adjusted.

Specifications:

Spring Casing - pressure diecast to BS1004 zinc or aluminum alloy LM25

Finish - Epoxy stove enamel

Spring - Clock type, spring steel

Ordering:

The spring return is available with the optional Adjustable Stroke Control but not with the Hall Effect or AC/DC Reed Switches.

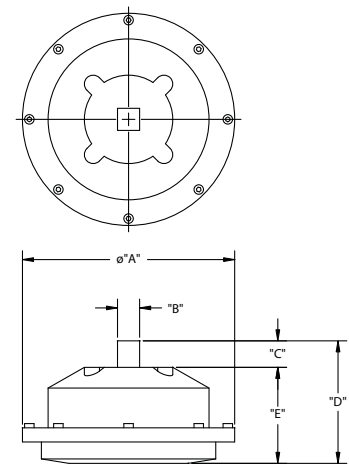

Dimensions (in.)					
Operator Size	A	B	C	D	E
2	4.22	.375	.500	2.25	1.78
3 & 4	5.97	.625	.750	4.06	3.23

Warranty Statement

Warranty

Seller warrants for one year from the date of shipment Seller's manufactured products to the extent that Seller will replace those having defects in material or workmanship when used for the purpose and in the manner which Seller recommends. If Seller's examination shall disclose to its satisfaction that the products are defective, and an adjustment is required, the amount of such adjustment shall not exceed the net sales price of the defective products only and no allowance will be made for labor or expense of repairing or replacing defective products or workmanship or damage resulting from the same. Seller warrants the products which it sells of other manufacturers to the extent of the warranties of their respective makers. Where engineering design or fabrication work is supplied, Buyer's acceptance of Seller's design or of delivery of work shall relieve Seller of all further obligation, other than as expressed in Seller's product warranty. THIS IS SELLER'S SOLE WARRANTY. SELLER MAKES NO OTHER WARRANTY OF ANY KIND, EXPRESSED OR IMPLIED. AND ALL IMPLIED WARRANTIES OF MERCHANTABILITY AND FITNESS FOR A PARTICULAR PURPOSE WHICH EXCEED SELLER'S AFORESTATED OBLIGATION ARE HEREBY DISCLAIMED BY SELLER AND EXCLUDED FROM THIS WARRANTY. Seller neither assumes, nor authorizes any person to assume for it, any other obligation in connection with the sale of its engineering designs or products. This warranty shall not apply to any products or parts of products which (a) have been repaired or altered outside of Seller's factory, in any manner; or (b) have been subjected to misuse, negligence or accidents; or (c) have been used in a manner contrary to Seller's instructions or recommendations. Seller shall not be responsible for design errors due to inaccurate or incomplete information supplied by Buyer or its representatives.

SELLER'S LIABILITY: Seller will not be liable for any loss, damage, cost of repairs, incidental or consequential damages of any kind, whether based upon warranty (except for the obligation accepted by Seller under "Warranty" above), contract or negligence, arising in connection with the design, manufacture, sale, use or repair of the products or of the engineering designs supplied to Buyer.



ENGINEERED FOR LIFE

Turn-Act
105 Commerce Way
Westminster, SC 29687
Tel: 864.647.9521
Fax: 864.647.9574
www.turn-act.com