

Pneumatic and Hydraulic Gate Valve Cylinders

through 24 inch bore



ITT

ENGINEERED FOR LIFE

Pneumatic Gate Valve Cylinders

Product Overviewpg. 1-2

2-1/2" to 24" Bore

How to Orderpg. 3

2-1/2" to 5" Bore

Technical Detailspg. 4

6" to 12" Bore

Technical Detailspg. 5

14" to 24" Bore

Technical Detailspg. 6

Components, Assembly and Maintenancepg. 7-8

Options and Specialspg. 9

Hydraulic Gate Valve Cylinders

Product Overviewpg. 10

1-1/2" to 8" Bore

How to Orderpg. 11

Technical Detailspg. 12

Components and Technical Detailspg. 13

Warranty Statementpg. 14

Valve Actuator markets are typically:

- Oil & Gas
- Power Gen
- Pulp and Paper
- Water

Aluminum Components – 2-1/2” through 12” Bore

The end plates and piston are made from high strength Aluminum. Combined with an Aluminum or composite cylinder tube the ITT GV actuators are over 50% lighter than actuators constructed from steel components. The end plates are black hard coat anodized for high corrosion and abrasion resistance.

End plates with rounded corners

All end plates have rounded versus sharp corners to minimize the potential for injury when handling the actuator.

Wear Band Piston

Piston includes a wear band to support the weight of the piston and rod assembly as well as to handle side loading. The wear band also serves to prevent the over compression of the piston seal and practically eliminates compression set of the piston seal during long idle periods.

Bright Zinc Coated Tie Rods

20” Gate Valve Cylinder



4” Gate Valve Cylinder



6” Gate Valve Cylinder



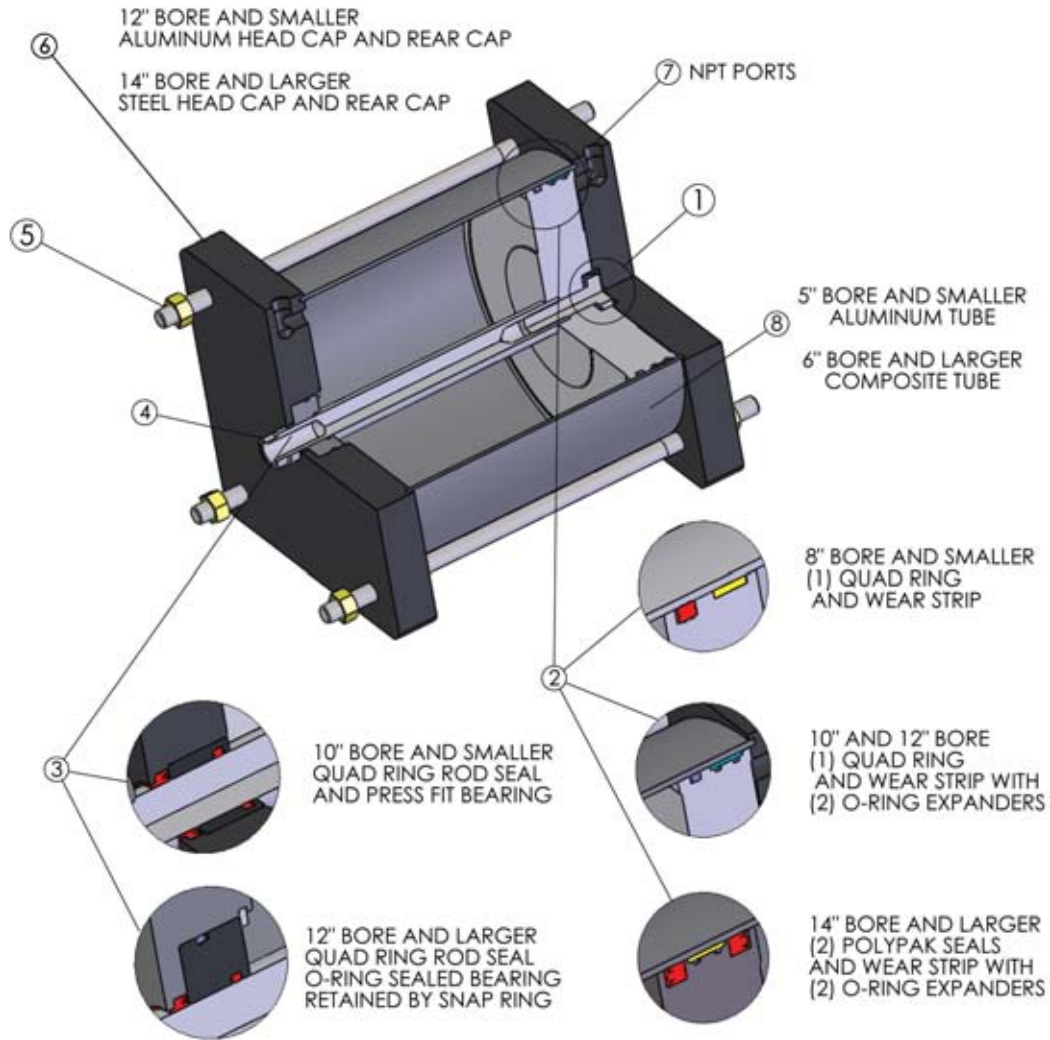

ITEM	COMPONENT	DESCRIPTION	ITEM	COMPONENT	DESCRIPTION
1	Piston	Aluminum/Steel*	5	Tie Rod and Nuts	Zinc Plated High Strength Alloy Steel
2	Piston Seals	Buna Nitrile Quad Ring / Polypak	6	Head and Rear Caps	Aluminum/Steel*
2	Wear Strip	Carbon Reinforced PTFE	7	Ports	NPT
3	Rod Bearing	Ductile Cast Iron	8	Tube	Aluminum/Composite*
4	Rod	Hard Chrome Plated High Strength Alloy Steel			

*Alternate materials of construction are available for services where aluminum or steel is not compatible.

TEMPERATURE RATINGS	
Standard Materials	
Buna-N seals and aluminum tube (2.5-5 in. bores): -20°F - 220°F (-29°C - 104°C)	
Buna-N seals and composite tube (6-24 in. bores): -20°F - 220°F (-29°C - 104°C)	
Optional Materials	
Buna-N seals and steel tube (all bore sizes): -20°F - 220°F (-29°C - 104°C)	
Fluorocarbon and aluminum tube (2.5-5 in. bores): -15°F - 400°F (-26°C - 204°C)	
Fluorocarbon and steel tube (6-24 in. bores): -15°F - 400°F (-26°C - 204°C)	

SERIES	ROD STYLE	BORE	STROKE	ROD EXTENSION	ROD MATERIAL	SEAL MATERIAL	TIE ROD EXTENSION (Rod End)	TIE ROD EXTENSION (Cap End)
GV		6	x 8.75	- W1.75	- 174	- F	- BB3.50	- Z1.50
1	2	3	4	5	6	7	8	9

Part Number Example: GV6X8.75-W1.75-174-F-BB3.50-Z1.50

1

Series	
GV	Gate Valve 150 PSI Max

4

Stroke	
X.XX	Indicate in Inches - Two Decimal Places

2

Rod Style	
	Single (Leave Blank)
D	Double Rod (Standard Model)

5

Rod Extension	
WX.XX	Leave Blank for Standard Dimension (See chart on pages 4-6) Indicate in Inches - Two Decimal Places

3

Bore	
25	2-1/2" Bore Cylinder
325	3-1/4" Bore Cylinder
4	4" Bore Cylinder
5	5" Bore Cylinder
6	6" Bore Cylinder
7	7" Bore Cylinder
8	8" Bore Cylinder
10	10" Bore Cylinder
12	12" Bore Cylinder
14	14" Bore Cylinder
16	16" Bore Cylinder
18	18" Bore Cylinder
20	20" Bore Cylinder
22	22" Bore Cylinder
24	24" Bore Cylinder

6

Rod Material	
	CR1050 Steel (Leave Blank)
174	CR Stainless Steel 17-4ph

7

Seal Material	
	Buna-N Seals (Leave Blank)
F	Fluorocarbon or "Viton" Seals

8

Tie Rod Extension (Rod End)	
BBX.XX	Leave Blank for Standard Dimension (See chart on pages 4-6) Indicate in Inches - Two Decimal Places

9

Tie Rod Extension (Cap End)	
ZX.XX	Leave Blank for Standard Dimension (See chart on pages 4-6) Indicate in Inches - Two Decimal Places

For Custom Gate Valve Cylinders Please Consult Factory.

Pneumatic Gate Valve Cylinders - 2 1/2" to 5" Bore

Technical Data

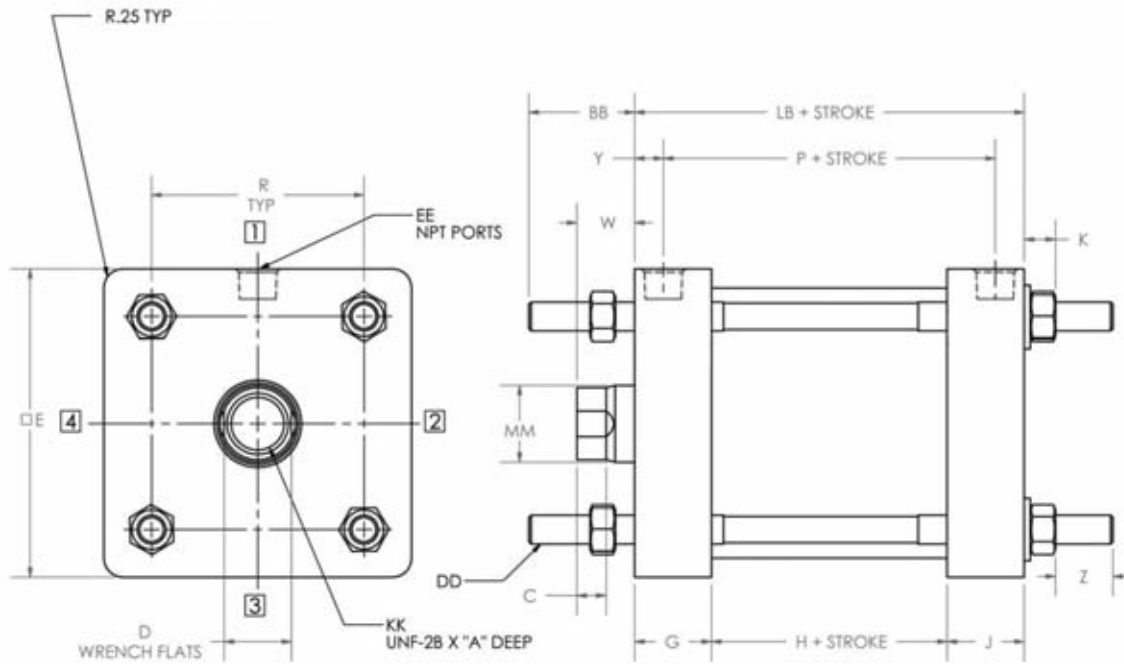

BORE in. (mm)	A in. (mm)	C in. (mm)	D in. (mm)	E in. (mm)	G in. (mm)	H in. (mm)	J in. (mm)	K in. (mm)	P in. (mm)	R in. (mm)	W in. (mm)	Y in. (mm)	Z in. (mm)	BB in. (mm)	DD in.	EE in.	KK in.	LB in. (mm)	MM in. (mm)
2.5 (63.5)	0.75 (19.1)	0.25 (6.4)	0.50 (12.7)	3.00 (76.2)	1.00 (25.4)	0.75 (19.1)	1.00 (25.4)	0.32 (8.1)	1.99 (50.5)	2.19 (55.6)	0.62 (15.7)	.038 (9.7)	0.56 (14.2)	1.12 (28.4)	.31"-24	.25"-18	.44"-20	2.75 (69.9)	0.62 (15.7)
3.25 (82.6)	1.12 (28.4)	0.38 (9.7)	0.88 (22.4)	4.00 (101.6)	1.00 (25.4)	0.75 (19.1)	1.00 (25.4)	0.41 (10.4)	1.99 (50.5)	2.76 (70.1)	0.75 (19.1)	0.38 (9.7)	0.75 (19.1)	1.38 (35.1)	.38"-24	.25"-18	.75"-16	2.75 (69.9)	1.00 (25.4)
4 (101.6)	1.12 (28.4)	0.38 (9.7)	0.88 (22.4)	4.50 (114.3)	1.00 (25.4)	1.00 (25.4)	1.00 (25.4)	0.41 (10.4)	2.12 (53.8)	3.32 (84.3)	0.75 (19.1)	0.44 (11.2)	0.75 (19.1)	1.38 (35.1)	.38"-24	.38"-18	.75"-16	3.00 (76.2)	1.00 (25.4)
5 (127.0)	1.12 (28.4)	0.38 (9.7)	0.88 (22.4)	5.50 (139.7)	1.00 (25.4)	1.00 (25.4)	1.00 (25.4)	0.56 (14.2)	2.12 (53.8)	4.10 (104.1)	0.75 (19.1)	0.44 (11.2)	0.75 (19.1)	1.81 (46.0)	.50"-20	.38"-18	.75"-16	3.00 (76.2)	1.00 (25.4)

THEORETICAL EXTEND FORCE LBS. (N)					THEORETICAL RETRACT FORCE LBS. (N)				
BORE in. (mm)	SUPPLY PRESSURE PSI (Bar)				ROD DIA. in. (mm)	SUPPLY PRESSURE PSI (Bar)			
	60 (4.14)	80 (5.52)	100 (6.89)	150 (10.34)		60 (4.14)	80 (5.52)	100 (6.89)	150 (10.34)
2.5 (63.5)	295 (1 310)	393 (1 747)	491 (2 184)	736 (3 275)	0.62 (15.7)	276 (1 230)	369 (1 639)	461 (2 049)	691 (3 074)
3.25 (82.6)	498 (2 214)	664 (2 952)	830 (3 690)	1244 (5 535)	1.00 (25.4)	451 (2 004)	601 (2 673)	751 (3 341)	1127 (5 011)
4 (101.6)	754 (3 354)	1005 (4 472)	1257 (5 590)	1885 (8 385)	1.00 (25.4)	707 (3 144)	942 (4 192)	1178 (5 240)	1767 (7 861)
5 (127.0)	1178 (5 240)	1571 (6 987)	1963 (8 734)	2945 (13 101)	1.00 (25.4)	1131 (5 031)	1508 (6 708)	1885 (8 385)	2827 (12 577)

BORE DIA. in. (mm)	ROD DIA. in. (mm)	A	B
		WEIGHT AT ZERO STROKE LBS. (kgs.)	WEIGHT PER INCH (mm) OF GV ACTUATOR LBS. (kgs.)
APPROXIMATE WEIGHT* (GV WITH ALUMINUM HEADS & ALUMINUM TUBE)			
2.5 (63.5)	0.62 (15.7)	2.7 (1.2)	0.3 (0.005)
3.25 (82.6)	1.00 (25.4)	4.8 (2.2)	0.5 (0.009)
4 (101.6)	1.00 (25.4)	6.3 (2.9)	0.6 (0.011)
5 (127.0)	1.00 (25.4)	11.5 (5.2)	0.7 (0.012)

*Total cylinder weight lbs. (kgs.) = A + (B x stroke)

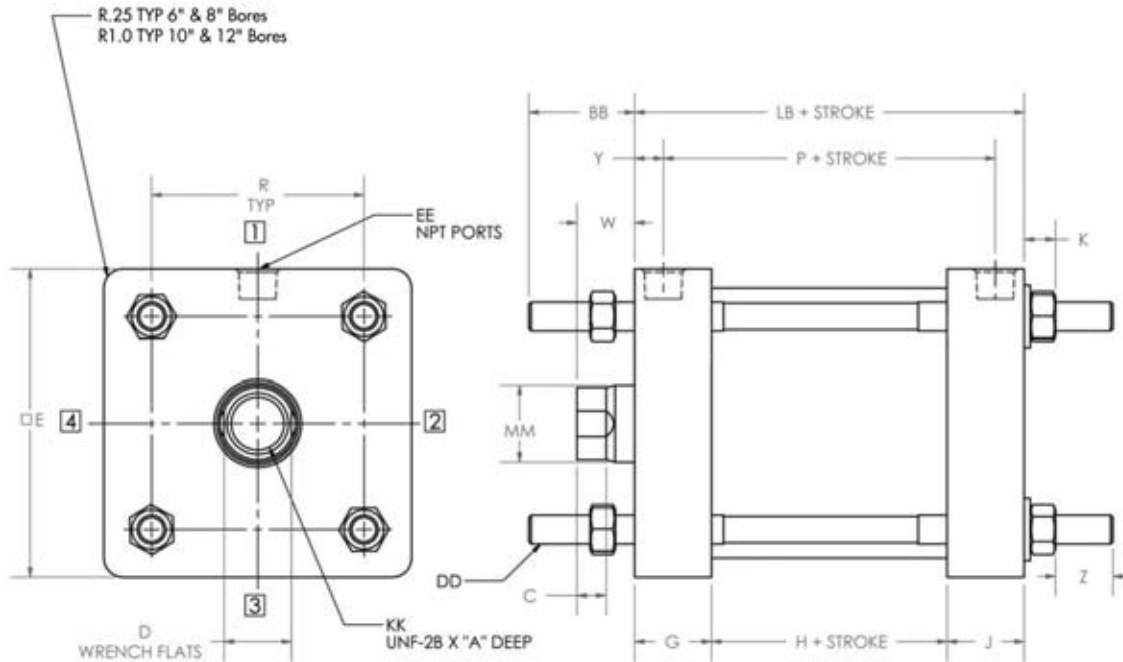

BORE in. (mm)	A in. (mm)	C in. (mm)	D in. (mm)	E in. (mm)	G in. (mm)	H in. (mm)	J in. (mm)	K in. (mm)	P in. (mm)	R in. (mm)	W in. (mm)	Y in. (mm)	Z in. (mm)	BB in. (mm)	DD in.	EE in.	KK in.	LB in. (mm)	MM in. (mm)
6 (152.4)	1.12 (28.4)	0.38 (9.7)	0.88 (22.4)	6.50 (165.1)	1.00 (25.4)	1.25 (31.8)	1.00 (25.4)	0.56 (14.2)	2.38 (60.5)	4.88 (124.0)	0.88 (22.4)	0.44 (11.2)	0.75 (19.1)	1.81 (46.0)	.50"-20	.38"-18	.75"-16	3.25 (82.6)	1.00 (25.4)
8 (203.2)	1.12 (28.4)	0.38 (9.7)	0.88 (22.4)	9.00 (228.6)	1.25 (31.8)	1.50 (38.1)	1.25 (31.8)	0.65 (16.5)	3.12 (79.2)	6.44 (163.6)	0.88 (22.4)	0.44 (11.2)	0.75 (19.1)	2.00 (50.8)	.62"-18	.38"-18	.75"-16	4.00 (101.6)	1.00 (25.4)
10 (254.0)	1.12 (28.4)	0.38 (9.7)	0.88 (22.4)	11.00 (279.4)	1.50 (38.1)	2.00 (50.8)	1.50 (38.1)	0.80 (20.3)	3.88 (98.6)	7.92 (201.2)	1.00 (25.4)	0.56 (14.2)	1.00 (25.4)	2.25 (57.2)	.75"-16	.50"-14	.75"-16	5.00 (127.0)	1.00 (25.4)
12 (304.8)	1.62 (41.1)	0.50 (12.7)	1.12 (28.4)	12.75 (323.9)	1.75 (44.5)	2.25 (57.2)	1.75 (44.5)	0.80 (20.3)	4.25 (108.0)	9.40 (238.8)	1.00 (25.4)	0.56 (14.2)	1.00 (25.4)	2.25 (57.2)	.75"-16	.50"-14	1.00"-14	5.75 (146.1)	1.38 (35.1)

THEORETICAL EXTEND FORCE LBS. (N)					THEORETICAL RETRACT FORCE LBS. (N)				
BORE in. (mm)	SUPPLY PRESSURE PSI (Bar)				ROD DIA. in. (mm)	SUPPLY PRESSURE PSI (Bar)			
	60 (4.14)	80 (5.52)	100 (6.89)	150 (10.34)		60 (4.14)	80 (5.52)	100 (6.89)	150 (10.34)
6 (152.4)	1696 (7 546)	2262 (10 062)	2827 (12 577)	4241 (18 866)	1.00 (25.4)	1649 (7 337)	2199 (9 782)	2749 (12 228)	4123 (18 342)
8 (203.2)	3016 (13 416)	4021 (17 887)	5027 (22 359)	7540 (33 539)	1.00 (25.4)	2969 (13 206)	3958 (17 608)	4948 (22 010)	7422 (33 015)
10 (254.0)	4712 (20 962)	6283 (27 949)	7854 (34 936)	11781 (52 404)	1.00 (25.4)	4665 (20 752)	6220 (27 670)	7775 (34 587)	11663 (51 880)
12 (304.8)	6786 (30 185)	9048 (40 247)	11310 (50 308)	16965 (75 462)	1.38 (35.1)	6696 (29 786)	8928 (39 714)	11160 (49 643)	16740 (74 464)

BORE DIA. in. (mm)	ROD DIA. in. (mm)	A	B
		WEIGHT AT ZERO STROKE LBS. (kgs.)	WEIGHT PER INCH (mm) OF GV ACTUATOR LBS. (kgs.)
APPROXIMATE WEIGHT* (GV WITH ALUMINUM HEADS & COMPOSITE TUBE)			
6 (152.4)	1.00 (25.4)	13.7 (6.2)	0.6 (0.010)
8 (203.2)	1.00 (25.4)	30.3 (13.8)	0.8 (0.014)
10 (254.0)	1.00 (25.4)	56.4 (25.6)	1.1 (0.020)
12 (304.8)	1.38 (35.1)	86.6 (39.3)	1.4 (0.024)

*Total cylinder weight lbs. (kgs.) = A + (B x stroke)

Pneumatic Gate Valve Cylinders - 14" to 24" Bore

Technical Data

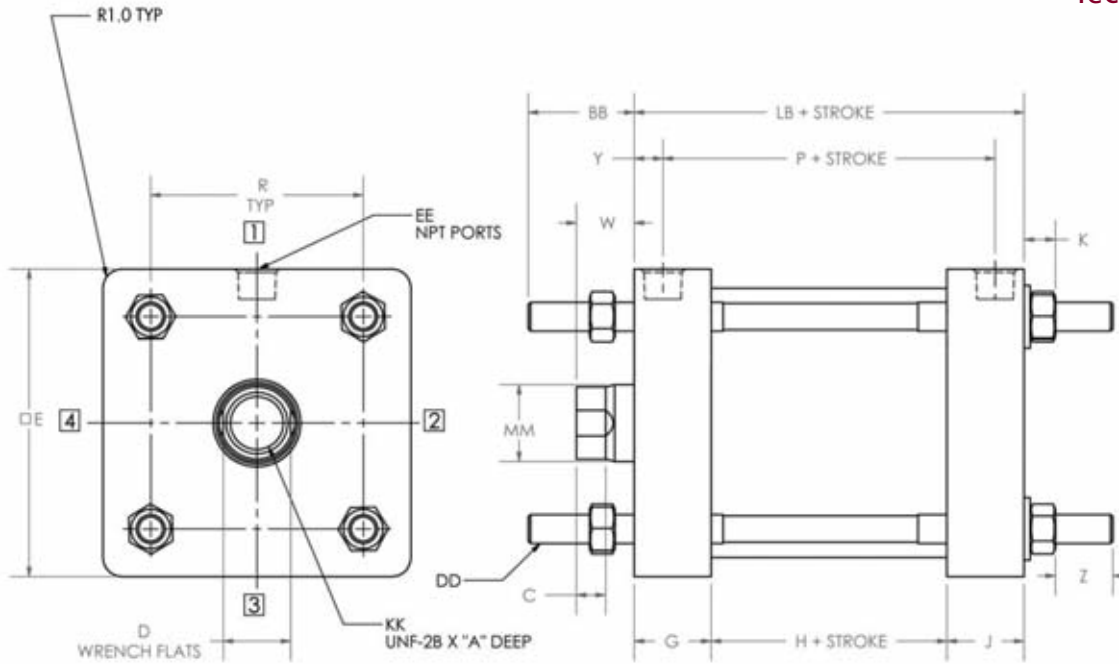

BORE in. (mm)	A in. (mm)	C in. (mm)	D in. (mm)	E in. (mm)	G in. (mm)	H in. (mm)	J in. (mm)	K in. (mm)	P in. (mm)	R in. (mm)	W in. (mm)	Y in. (mm)	Z in. (mm)	BB in. (mm)	DD in.	EE in.	KK in.	LB in. (mm)	MM in. (mm)
14 (355.6)	1.62 (41.1)	0.50 (12.7)	1.12 (28.4)	14.75 (374.7)	1.50 (38.1)	2.67 (67.8)	1.50 (38.1)	0.78 (19.8)	4.29 (109.0)	10.90 (276.9)	1.00 (25.4)	0.69 (17.5)	1.12 (28.4)	2.50 (63.5)	.88"-14	.75"-14	1.00"-14	5.67 (144.0)	1.38 (35.1)
16 (406.4)	1.62 (41.1)	0.62 (15.7)	1.50 (38.1)	17.00 (431.8)	1.50 (38.1)	2.67 (67.8)	1.50 (38.1)	0.86 (21.8)	4.29 (109.0)	12.59 (319.8)	1.25 (31.8)	0.69 (17.5)	1.12 (28.4)	2.75 (69.9)	1.00"-14	.75"-14	1.00"-14	5.67 (144.0)	1.75 (44.5)
18 (457.2)	2.25 (57.2)	0.75 (19.1)	1.69 (42.9)	19.00 (482.6)	1.75 (44.5)	2.67 (67.8)	1.75 (44.5)	1.00 (25.4)	4.29 (109.0)	14.14 (359.2)	1.50 (38.1)	0.94 (23.9)	1.25 (31.8)	3.25 (82.6)	1.12"-12	.75"-14	1.50"-12	6.17 (156.7)	2.00 (50.8)
20 (508.0)	2.25 (57.2)	0.75 (19.1)	1.69 (42.9)	21.00 (533.4)	2.00 (50.8)	2.67 (67.8)	2.00 (50.8)	1.09 (27.7)	4.29 (109.0)	15.77 (400.6)	1.50 (38.1)	1.19 (30.2)	1.25 (31.8)	3.25 (82.6)	1.25"-12	.75"-14	1.50"-12	6.67 (169.4)	2.00 (50.8)
22 (558.8)	3.50 (88.9)	0.75 (19.1)	2.62 (66.5)	23.00 (584.2)	2.00 (50.8)	3.50 (88.9)	2.00 (50.8)	1.09 (27.7)	5.12 (130.0)	17.15 (435.6)	2.25 (57.2)	1.19 (30.2)	1.25 (31.8)	3.50 (88.9)	1.25"-12	.75"-14	2.25"-12	7.50 (190.5)	3.00 (76.2)
24 (609.6)	3.50 (88.9)	0.75 (19.1)	3.00 (76.2)	25.25 (641.4)	2.50 (63.5)	3.50 (88.9)	2.50 (63.5)	1.09 (27.7)	5.50 (139.7)	18.74 (476.0)	2.25 (57.2)	1.50 (38.1)	1.25 (31.8)	3.50 (88.9)	1.25"-12	.75"-14	2.50"-12	8.50 (215.9)	3.50 (88.9)

THEORETICAL EXTEND FORCE LBS. (N)					THEORETICAL RETRACT FORCE LBS. (N)				
BORE in. (mm)	SUPPLY PRESSURE PSI (Bar)				ROD DIA. in. (mm)	SUPPLY PRESSURE PSI (Bar)			
	60 (4.14)	80 (5.52)	100 (6.89)	150 (10.34)		60 (4.14)	80 (5.52)	100 (6.89)	150 (10.34)
14 (355.6)	9236 (41 085)	12315 (54 780)	15394 (68 475)	23091 (102 713)	1.38 (35.1)	9147 (40 686)	12195 (54 248)	15244 (67 810)	22866 (101 715)
16 (406.4)	12064 (53 662)	16085 (71 549)	20106 (89 437)	30159 (134 155)	1.75 (44.5)	11919 (53 020)	15893 (70 694)	19866 (88 367)	29798 (132 550)
18 (457.2)	15268 (67 916)	20358 (90 555)	25447 (113 193)	38170 (169 790)	2.00 (50.8)	15080 (67 078)	20106 (89 437)	25133 (111 796)	37699 (167 694)
20 (508.0)	18850 (83 847)	25133 (111 796)	31416 (139 745)	47124 (209 618)	2.00 (50.8)	18661 (83 009)	24881 (110 678)	31102 (138 348)	46653 (207 521)
22 (558.8)	22808 (101 455)	30411 (135 273)	38013 (169 091)	57020 (253 637)	3.00 (76.2)	22384 (99 568)	29845 (132 758)	37306 (165 947)	55960 (248 921)
24 (609.6)	27143 (120 740)	36191 (160 986)	45239 (201 233)	67858 (301 849)	3.50 (88.9)	26566 (118 172)	35421 (157 563)	44277 (196 953)	66415 (295 430)

BORE DIA. in. (mm)	ROD DIA. in. (mm)	A		B	
		WEIGHT AT ZERO STROKE LBS. (kgs.)		WEIGHT PER INCH (mm) OF GV ACTUATOR LBS. (kgs.)	
APPROXIMATE WEIGHT* (GV WITH STEEL HEADS & COMPOSITE TUBE)					
14 (355.6)	1.38 (35.1)	296.9 (134.7)		1.7 (0.030)	
16 (406.4)	1.75 (44.5)	386.5 (175.3)		2.7 (0.048)	
18 (457.2)	2.00 (50.8)	537.8 (243.9)		3.3 (0.059)	
20 (508.0)	2.00 (50.8)	742.2 (336.7)		3.7 (0.66)	
22 (558.8)	3.00 (76.2)	983.9 (446.3)		4.9 (0.87)	
24 (609.6)	3.50 (88.9)	1359.3 (616.6)		5.8 (0.104)	

*Total cylinder weight lbs. (kgs.) = A + (B x stroke)

CAUTION: CHECK MAXIMUM OPERATING PRESSURE LISTED ON CYLINDER LABEL BEFORE APPLYING PRESSURE TO CYLINDER. EXCEEDING THE PRESSURE RATING LISTED ON THE CYLINDER MAY CAUSE FAILURE WHICH MAY ENDANGER PERSONNEL AND/OR EQUIPMENT.

WARNING: READ INSTALLATION SERVICE INSTRUCTIONS AND GENERAL PARTS BREAKDOWN BEFORE INSTALLATION, OPERATION OR SERVICING. THIS MANUAL IS NOT FOR SPRING LOADED CYLINDERS.

NOTICE: DISASSEMBLY OF THIS PRODUCT WILL VOID WARRANTY

GV ACTUATOR INSTALLATION AND MAINTENANCE INSTRUCTIONS

1. **GENERAL:** The parts drawing on Page 3 shows a complete listing of parts and is applicable to all standard series GV air cylinders (2.50" through 24.00" bores only). This parts drawing when used in conjunction with the parts listed and kits, should facilitate the ordering of any replacement parts or kits by specifying:

- A. Cylinder Part Number as it appears on the identification label on the cylinder tube located on the port side.
- B. Item number and part name or kit type and name.

2. **INSTALLATION OF CYLINDER:** The seals and packing of standard air cylinders operate within the temperature range of -20°F (-29°C) to 220°F (104°C). Baffles are recommended to shield cylinder from heat, whenever practical. For unusually high or low temperatures, different seal materials may have been used. (Contact ITT Westminster @ 864-647-9521). For the cylinder to perform well, it must be properly installed. Alignment of the cylinder with load is most important. Forcing the rod or mounting bolts into position indicates that the cylinder is not properly aligned, and permanent damage may result from such installation. Protective port covers should not be removed before installing air line connections as dirt or other foreign particles may enter the cylinder. All pipe and fittings must be clean before making final connections.

3. PROCEDURE FOR REPACKING CYLINDER:

NOTE: DISASSEMBLY BEFORE WARRANTY PERIOD EXPIRES WILL VOID WARRANTY! (See Page 8 for Disassembly/Parts Diagram)

- A. Disconnect air lines from head cap and rear cap ports of cylinder.
- B. Remove the tie rod nuts (5) and tie rods (4).
Note: Measure and record tie rod length protruding from the head cap.
- C. Remove rear cap (2) and then head cap (1). The rod bearing (11) will come off with the head cap.
- D. Remove piston and rod assembly from tube (3).
- E. To disassemble rear cap (2), remove cap O-ring or gasket (13).
- F. To disassemble head cap (1):
 - 1. Remove head cap O-ring or gasket (13).
 - 2. 12.00"–24.00" bore sizes remove bearing retainer ring (12) and rod bearing (11) from head cap (1).
NOTE: 2.50"–10.00" rod bearings (11) are press fit – DO NOT REMOVE.
 - 3. Remove rod seal (15). For 12.00"–24.00" bore sizes remove the rod bearing O-ring (17).
 - 4. Remove rod wiper (16) from the head cap.

4. **CLEANING:** Clean all parts thoroughly. The packing and seals in this cylinder are compatible with hydraulic oils, air, and neutral fluids. The cleaning agent must also be compatible to avoid damage to packing and seals. Whenever a particular lubricant is specified for a particular installation, do not deviate from the specification without checking for compatibility.

5. INSPECTION

- A. Inspect all packing and seals for swelling, shrinkage, wear, nicks, cuts

- B. Check and inspect bore of tube for scratches, excessive wear, and any other defect that might damage piston packing or cause piston bypass.
- C. Inspect piston rod for signs of wear, nicks, dents, scratches, or anything that may damage rod packing or rod bearing.
- D. Inspect wear strip for excessive uneven wear.

NOTE: Excessive wear on one side of piston rod, rod bearing, or wear strip usually indicates misalignment in installation and should be corrected.

6. **REPLACEMENT:** Replace all damaged packing seals, rod wiper, and wear strip.

7. **LUBRICATION:** Series GV Actuators are pre-lubricated during initial assembly. During the repacking of an air cylinder, pre-lubrication should be re-applied to prevent seal damage and obtain maximum life. Lubricant is applied to the rod seals, piston packing, and liberally to the tube bore. Use NYE RHEOLUBE 368AXF or equivalent.

8. **REASSEMBLY:** The procedure for reassembly is essentially the reverse of disassembly. However, the following exceptions and considerations should be noted:

- A. All O-rings and gaskets should be well-coated with lubricant after they are installed in their respective grooves and prior to reassembly with the mating part. Care must be taken when assembling O-rings, gaskets and packing that they are not damaged, as this will cause leakage.
- B. Tie rod threads and nut bearing faces should be well lubricated to allow tightening the nuts evenly for proper pre-stressing. To avoid twisting of the tie rods during tightening, hold with vise grip or clamp. To assure equal pre-stressing of the tie rods, first thread on nuts evenly and snug to align assembly, then the nuts are to be tightened using a diagonal pattern. For proper tie rod pre-stressing, they should be torqued as recommended (See "GV Series Tie Rod Torque Reference" table below).

9. PISTON-ROD

NOTE: The piston-rod assembly should not require disassembly unless replacement of piston (7) or the piston rod (8) is required. It is recommended this be returned to the factory for repair. (Contact ITT Westminster @ 864-647-9521 for additional information.)

10. TESTING

After the cylinder has been completely reassembled, it should be tested, either on a test bench or in the regular installation. Watch for the following as the cylinder is cycled at operating pressures.

- A. Rod gland leakage.
- B. Leakage at the head and rear cap locations of the tube O-rings or gaskets.

NOTE: This product is not to be modified in any fashion without prior written approval from ITT.

NOTE: If cylinders are to be stored for prolonged periods, contact ITT or instructions.

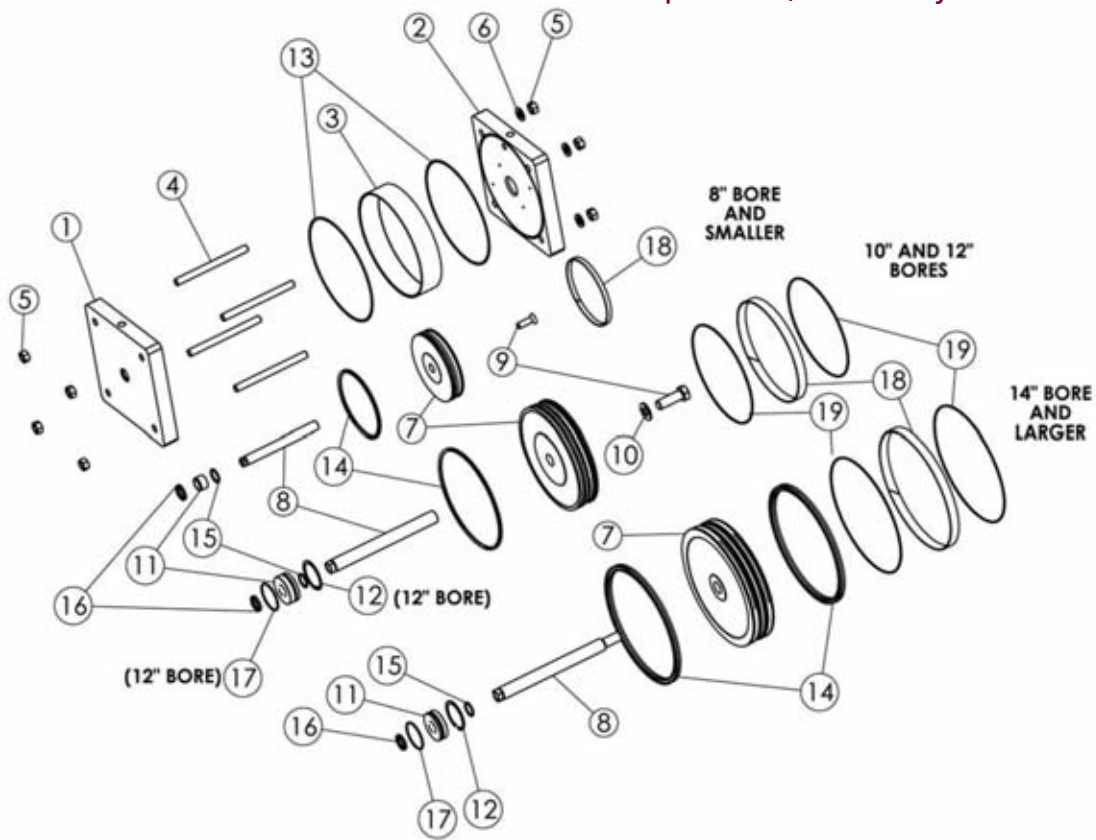

Gate Valve Cylinder Tie Rod Torque Reference

TUBE MATERIAL	CYLINDER BORE SIZE														
	2.5	3.25	4.0	5.0	6.0	7.0	8.0	10.0	12.0	14.0	16.0	18.0	20.0	22.0	24.0
Aluminum lb-ft (Nm)	6 (8.1)	18 (24.4)	18 (24.4)	37 (50.1)	N/A										
Composite lb-ft (Nm)	N/A				13 (17.6)	25 (33.9)	29 (39.3)	56 (75.9)	81 (109.8)	128 (173.4)	196 (268.3)	282 (382.1)	359 (486.4)	734 (994.6)	787 (1 066.4)

Component

Actuator Parts

1. Head Cap
2. Rear Cap
3. Tube
4. Tie Rods
5. Tie Rod Nuts
6. Tie Rod Washers
7. Piston
8. Piston Rod
9. Piston to Rod Screw
10. Piston to Rod Washer
11. Rod Bearing
12. Retaining Ring

Seals

13. Tube Seals
 14. Piston Seals
 15. Rod Seal
 16. Rod Wiper
 17. Rod Bearing O-Ring
 18. Piston Wear Strip
 19. Wear Strip O-Ring
- Expanders

Gate Valve Cylinder Repair Kits

CYLINDER BORE		PISTON ROD DIAMETER		SEAL MATERIAL		REPAIR KITS CONTAIN THE FOLLOWING ITEM NUMBERS
Inches	(mm)	Inches	(mm)	BUNA-N	FLUOROCARBON	
2.5	63.5	0.63	16.0	RKGV25	RKGVF25	#13, #14, #15, #16, #18
3.25	82.6	1	25.4	RKGV325	RKGVF325	#13, #14, #15, #16, #18
4	101.6	1	25.4	RKGV4	RKGVF4	#13, #14, #15, #16, #18
5	127.0	1	25.4	RKGV5	RKGVF5	#13, #14, #15, #16, #18
6	152.4	1	25.4	RKGV6	RKGVF6	#13, #14, #15, #16, #18
7	177.8	1	25.4	RKGV7	RKGVF7	#13, #14, #15, #16, #18
8	203.2	1	25.4	RKGV8	RKGVF8	#13, #14, #15, #16, #18
10	254.0	1	25.4	RKGV10	RKGVF10	#13, #14, #15, #16, #17, #18, #19
12	304.8	1.38	35.1	RKGV12	RKGVF12	#13, #14, #15, #16, #17, #18, #19
14	355.6	1.38	35.1	RKGV14	RKGVF14	#13, #14, #15, #16, #17, #18, #19
16	406.4	1.75	44.5	RKGV16	RKGVF16	#13, #14, #15, #16, #17, #18, #19
18	457.2	2	50.8	RKGV18	RKGVF18	#13, #14, #15, #16, #17, #18, #19
20	508.0	2	50.8	RKGV20	RKGVF20	#13, #14, #15, #16, #17, #18, #19
22	558.8	3	76.2	RKGV22	RKGV22	#13, #14, #15, #16, #17, #18, #19
24	609.6	3.5	88.9	RKGV24	RKGV24	#13, #14, #15, #16, #17, #18, #19

At ITT we produce the following custom options and specials:

- Spring Extend - Air Retract
- Spring Retract - Air Extend
- Steel Tubes
- Adjustable Stops
- Special Coatings
- Special Mountings
- All Stainless Steel Components
- Multi-Piston for:
 - Multi-Power
 - Multi-Position
- Special Ports
- Oversized Rods
- Custom Rod Configurations

If you can imagine a design, ITT can provide the solution.



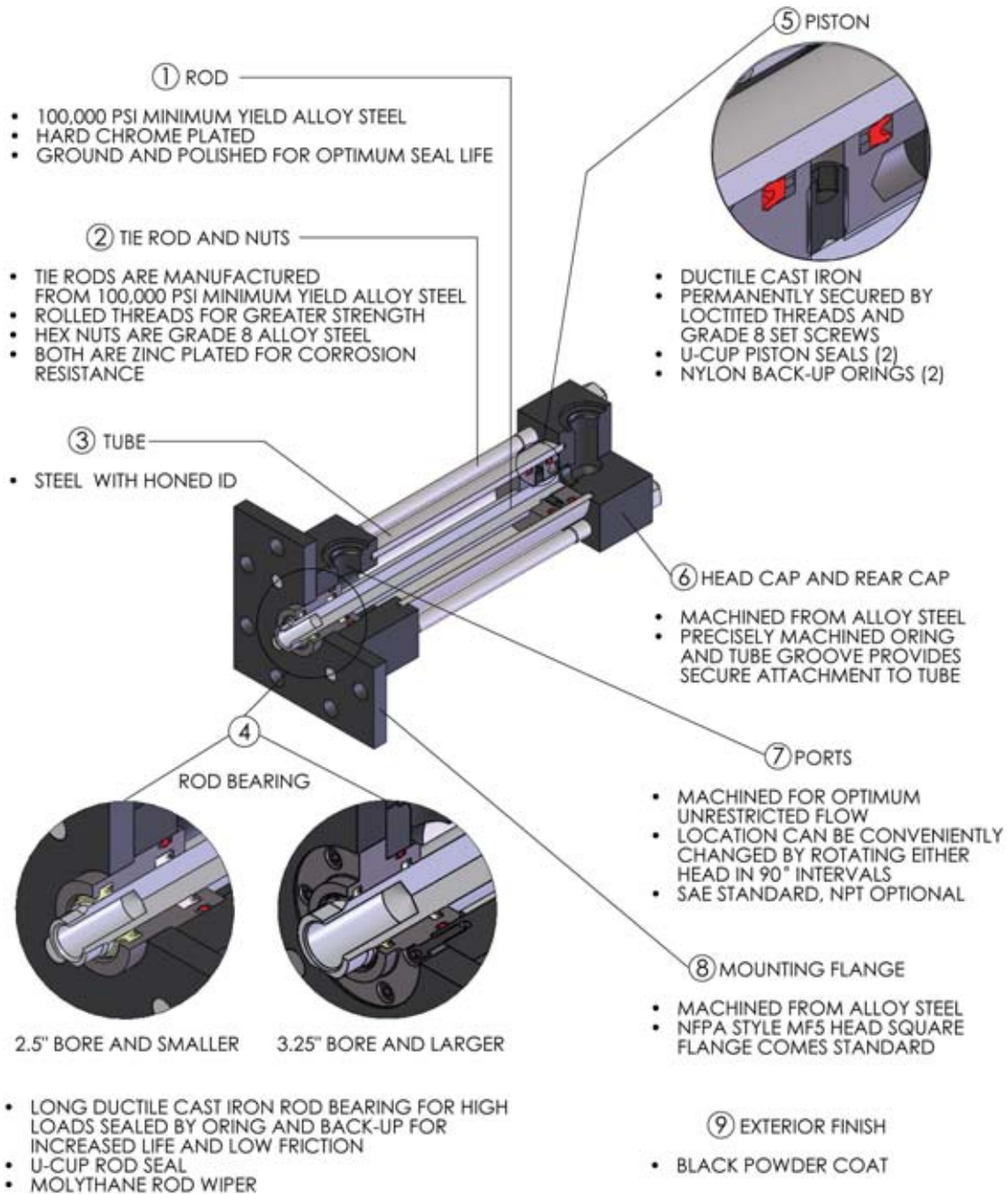

TEMPERATURE RATINGS	
Standard Materials	
Urethane Seals: -30°F (-40° C) TO 175°F (82° C)	
Optional Materials	
Viton Seals: -15°F (-26° C) TO 400°F (204° C)	

TYPE	PRESSURE	SERIES	BORE	STROKE	MOUNT	ROD END STYLE	ROD DIAMETER	ROD EXTENSION (OPTIONAL)	ROD MATERIAL	SEAL MATERIAL	PORT OPTION
H	3	GV	15	x 1.75	MF5			W3.00		F	
1	2	3	4	5	6	7	8	9	10	11	12

Part Number Example: H3GV15x1.75-MF5-W3.00-F

1	Type
H	Hydraulic

2	Pressure
3	3000 PSI Max

3	Series
GV	Gate Valve Series

4	Bore	
15	1-1/2"	Bore Cylinder
2	2"	Bore Cylinder
25	2-1/2"	Bore Cylinder
325	3-1/4"	Bore Cylinder
4	4"	Bore Cylinder
5	5"	Bore Cylinder
6	6"	Bore Cylinder
8	8"	Bore Cylinder

5	Stroke
X.XX	Indicate in Inches - Two Decimal Places

6	Mounting Style
MF5	NFPA Style Square Front Flange Mount

7	Rod End Style
	Standard Style 4-Short Female (Leave Blank)
2	Style 2 - Small Male
5	Style 5 - Intermediate Male

8	Rod Diameter
	Standard Rod Diameter *(Leave Blank)
X.XX	Optional Rod Diameter - Inches - Two Decimal Places
	Ex. 1.38 = 1-3/8" Rod Diameter Consult Factory for Available Sizes

9	Rod Extension
	Standard Rod Extension (Leave Blank)
WX.XX	Optional Rod Extension - Inches - Two Decimal Places
	Ex. W2.25 = 2.25" Rod Protrusion When Retracted

10	Rod Material
	CR1050 Steel (Leave Blank)
174	Chrome Plated Stainless Steel 17-4ph

11	Seal Material
	Standard Urethane (Leave Blank)
F	Fluorocarbon or "Viton" Seals

12	Port Type
	Standard SAE Ports (Leave Blank)
xNPT	Optional NPT Ports (Specify Size - Ex. 3/4NPT)

Standard Rod Diameters*	
Bore	Diameter
1.5	5/8
2	1
2.5	1
3.25	1-3/8"
4	1-3/4"
5	2
6	2-1/2"
8	3-1/2"

For Custom Gate Valve Cylinders Please Consult Factory.

Hydraulic Gate Valve Cylinders - 1-1/2" to 8" Bore

Technical Data

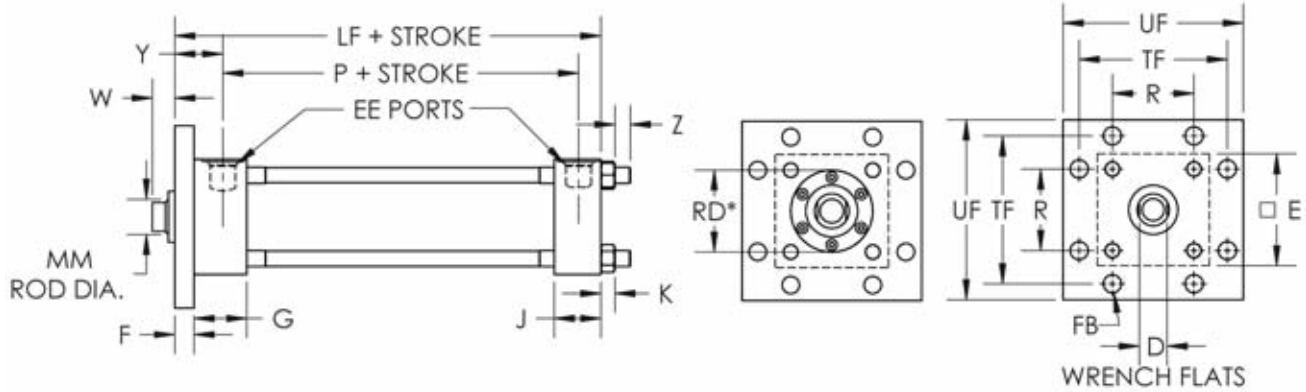

BORE in. (mm)	EE-NPT	EE-SAE	F in. (mm)	G in. (mm)	J in. (mm)	K in. (mm)	P in. (mm)	W in. (mm)	Y in. (mm)	Z in. (mm)	LF in. (mm)	MM in. (mm)
1.5 (38.1)	1/2	8	0.38 (9.53)	1.84 (46.83)	1.59 (40.48)	0.34 (8.73)	2.88 (73.03)	0.63 (15.88)	1.38 (34.93)	0.22 (5.56)	5.19 (131.83)	0.63 (15.88)
2 (50.8)	1/2	8	0.63 (15.88)	1.84 (46.83)	1.59 (40.48)	0.44 (11.11)	2.81 (71.44)	0.75 (19.05)	1.69 (42.86)	0.44 (11.11)	5.25 (133.35)	1.00 (25.40)
2.5 (63.5)	1/2	8	0.63 (15.88)	1.84 (46.83)	1.59 (40.48)	0.44 (11.11)	2.94 (74.61)	0.75 (19.05)	1.69 (42.93)	0.31 (7.94)	5.38 (136.53)	1.00 (25.40)
3.25 (82.6)	3/4	12	0.75 (19.05)	2.06 (52.39)	1.81 (46.04)	0.56 (14.29)	3.50 (88.90)	0.88 (22.23)	1.88 (47.63)	0.59 (15.08)	6.25 (158.75)	1.38 (34.93)
4 (101.6)	3/4	12	0.88 (22.23)	2.06 (52.39)	1.81 (46.04)	0.56 (14.29)	3.75 (95.25)	1.00 (25.40)	2.00 (50.80)	0.25 (6.35)	6.63 (168.28)	1.75 (44.45)
5 (127.0)	3/4	12	0.88 (22.23)	2.13 (53.98)	1.88 (47.63)	0.81 (20.64)	4.25 (107.95)	1.13 (28.58)	2.00 (50.80)	0.44 (11.11)	7.13 (180.98)	2.00 (50.80)
6 (152.4)	1	16	1.00 (25.40)	2.25 (57.15)	2.25 (57.15)	0.88 (22.23)	5.00 (127.00)	1.25 (31.75)	2.19 (55.56)	1.18 (29.97)	8.38 (212.73)	2.50 (63.50)
8 (203.2)	1-1/4	24	1.00 (25.40)	3.00 (76.20)	3.00 (76.20)	1.13 (28.58)	6.38 (161.93)	1.25 (31.75)	2.56 (65.09)	0.69 (17.46)	10.50 (266.70)	3.50 (88.90)

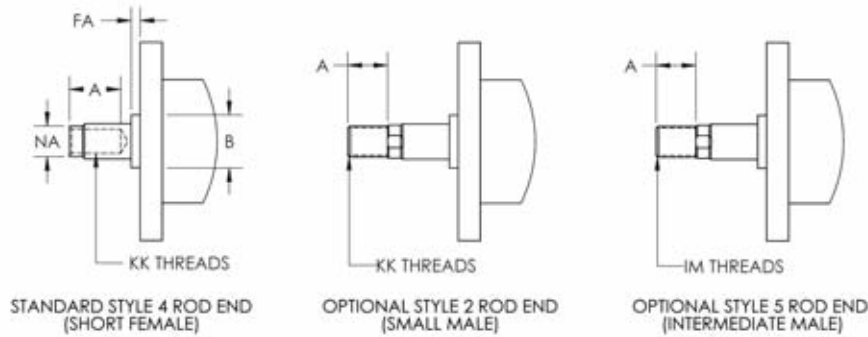

BORE in. (mm)	A in. (mm)	B in. (mm)	D in. (mm)	E in. (mm)	R in. (mm)	FA in. (mm)	FB in. (mm)	IM*	KK	NA in. (mm)	RD* in. (mm)	TF in. (mm)	UF in. (mm)
1.5 (38.1)	0.75 (19.05)	1.13 (28.58)	0.50 (12.70)	2.50 (63.50)	1.63 (41.28)	0.25 (6.35)	0.38 (9.53)	1/2-20	7/16-20	0.56 (14.29)	N/A	3.44 (87.33)	4.25 (107.95)
2 (50.8)	1.13 (28.58)	1.50 (38.10)	0.88 (22.23)	3.00 (76.20)	2.05 (52.10)	0.25 (6.35)	0.50 (12.70)	7/8-14	3/4-16	0.94 (23.81)	N/A	4.13 (104.78)	5.13 (130.18)
2.5 (63.5)	1.13 (28.58)	1.50 (38.10)	0.88 (22.23)	3.50 (88.90)	2.55 (64.67)	0.25 (6.35)	0.50 (12.70)	7/8-14	3/4-16	0.94 (23.81)	N/A	4.63 (117.48)	5.63 (142.88)
3.25 (82.6)	1.63 (41.28)	2.00 (50.80)	1.13 (28.58)	4.50 (114.30)	3.25 (82.63)	0.25 (6.35)	0.63 (15.88)	1-1/4-12	1-14	1.94 (49.21)	3.25 (82.55)	5.88 (149.23)	7.13 (180.98)
4 (101.6)	2.00 (50.80)	2.38 (60.33)	1.50 (38.10)	5.00 (127.00)	3.82 (96.98)	0.25 (6.35)	0.63 (15.88)	1-1/2-12	1-1/4-12	1.69 (42.86)	3.75 (95.25)	6.38 (161.93)	7.63 (193.68)
5 (127.0)	2.25 (57.15)	2.63 (66.68)	1.69 (42.86)	6.50 (165.10)	4.95 (125.73)	0.25 (6.35)	0.88 (22.23)	1-3/4-12	1-1/2-12	1.94 (49.21)	4.13 (104.78)	8.18 (207.77)	9.75 (247.65)
6 (152.4)	3.00 (76.20)	3.13 (79.38)	2.06 (52.32)	7.50 (190.50)	5.73 (145.49)	0.25 (6.35)	1.00 (25.40)	2-1/4-12	1-7/8-12	2.38 (60.33)	4.50 (114.30)	9.44 (239.71)	11.25 (285.75)
8 (203.2)	3.50 (88.90)	4.25 (107.95)	3.00 (76.20)	9.50 (241.30)	7.50 (190.37)	0.25 (6.35)	1.25 (31.75)	3-1/4-12	2-1/2-12	3.38 (85.73)	5.75 (146.05)	11.81 (300.04)	14.00 (355.60)

*Note: Dimension is for optional style 5 Rod End Only (See Diagram) RD represents the diameter of the threaded bearing (only used on 3.25" and larger bores)

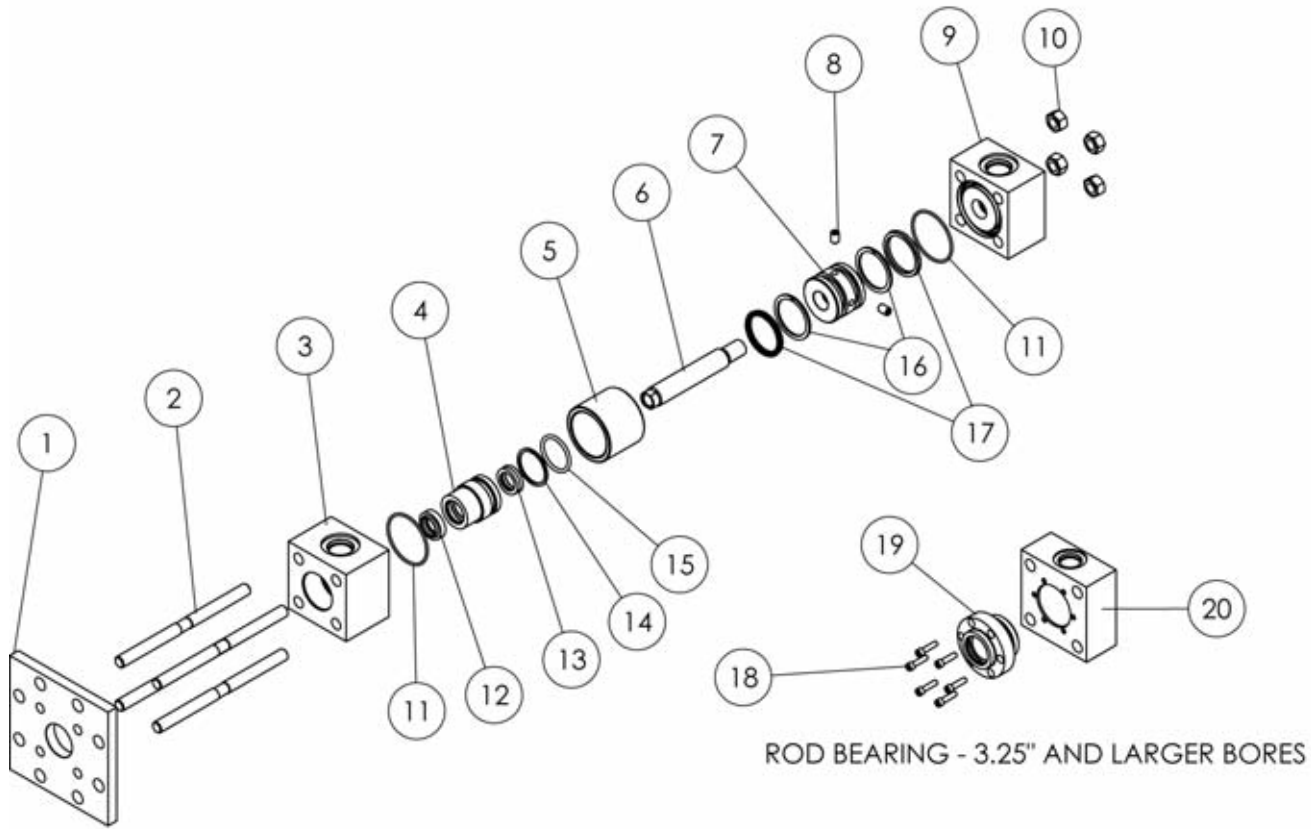

Component

Actuator Parts

1. MF5 Style Flange
2. Tie Rods
3. Head Cap
4. Rod Bearing
5. Tube
6. Rod
7. Piston
8. Piston Retaining Screw
9. Rear Cap
10. Tie Rod Nuts

Seals

11. Cap O-Rings
12. Rod Wiper
13. Rod Seal
14. Rod Bearing O-Ring Backup
15. Rod Bearing O-Ring
16. Piston Seal Backup
17. Piston U-Cup Seals

3.25" Bore and Larger

18. Bearing Retaining Screws
19. Threaded Rod Bearing
20. Head Cap

BORE in. (mm)	THEORETICAL EXTEND FORCE LBS. (N)				ROD DIA.	THEORETICAL RETRACT FORCE LBS. (N)			
	SUPPLY PRESSURE PSI (Bar)					SUPPLY PRESSURE PSI (Bar)			
	1500 (103.4)	2000 (137.9)	2500 (172.4)	3000 (206.8)		1500 (103.4)	2000 (137.9)	2500 (172.4)	3000 (206.8)
1.5 (38.1)	2651 (11 791)	3534 (15 721)	4418 (19 652)	5301 (23 582)	0.63 (15.9)	2191 (9 744)	2921 (12 992)	3651 (16 240)	4381 (19 488)
2 (50.8)	4712 (20 962)	6283 (27 949)	7854 (34 936)	9425 (41 924)	1.00 (25.4)	3534 (15 721)	4712 (20 962)	5890 (26 202)	7069 (31 443)
2.5 (63.5)	7363 (32 753)	9817 (43 670)	12272 (54 588)	14726 (65 505)	1.00 (25.4)	6185 (27 512)	8247 (36 683)	10308 (45 854)	12370 (55 025)
3.25 (82.6)	12444 (55 352)	16592 (73 803)	20739 (92 254)	24887 (110 704)	1.38 (34.9)	10216 (45 444)	13622 (60 593)	17027 (75 741)	20433 (90 889)
4 (101.6)	18850 (83 847)	25133 (111 796)	31416 (139 745)	37699 (167 694)	1.75 (44.5)	15242 (67 798)	20322 (90 398)	25403 (112 997)	30483 (135 596)
5 (127.0)	29452 (131 011)	39270 (174 681)	49087 (218 352)	58905 (262 022)	2.00 (50.8)	24740 (110 049)	32987 (146 732)	41233 (183 415)	49480 (220 098)
6 (152.4)	42412 (188 656)	56549 (251 541)	70686 (314 426)	84823 (377 312)	2.50 (63.5)	35048 (155 903)	46731 (207 871)	58414 (259 838)	70097 (311 806)
8 (203.2)	75398 (335 388)	100531 (447 184)	125664 (558 980)	150796 (670 776)	3.50 (88.9)	60967 (271 193)	81289 (361 590)	101611 (451 988)	121933 (542 385)

BORE DIA. in. (mm)	A	B	C
	WEIGHT AT ZERO STROKE LBS. (kgs)	WEIGHT PER INCH (mm) OF ACTUATOR STROKE LBS. (kgs)	WEIGHT PER INCH (mm) OF ADDED ROD LENGTH LBS. (kgs)
1.5 (38.1)	8.4 (3.81)	0.5 (0.008)	0.1 (0.002)
2 (50.8)	14.5 (6.58)	0.8 (0.014)	0.2 (0.004)
2.5 (63.5)	19.7 (8.95)	1.1 (0.019)	0.2 (0.004)
3.25 (82.6)	36.6 (16.62)	1.8 (0.031)	0.5 (0.009)
4 (101.6)	49.2 (22.31)	2.4 (0.043)	0.7 (0.013)
5 (127.0)	88.4 (40.10)	3.8 (0.068)	0.9 (0.016)
6 (152.4)	136.3 (61.82)	5.1 (0.091)	1.4 (0.025)
8 (203.2)	253.7 (115.08)	9.1 (0.163)	2.8 (0.049)

*Total actuator weight lbs. (kgs.) = A + (B x Stroke) + (C x Added Rod Length)

Gate Valve Cylinder Series Warranty

Seller warrants for one year from the date of shipment Seller's manufactured products to the extent that Seller will replace those having defects in material or workmanship when used for the purpose and in the manner which Seller recommends. If Seller's examination shall disclose to its satisfaction that the products are defective, and an adjustment is required, the amount of such adjustment shall not exceed the net sales price of the defective products only and no allowance will be made for labor or expense of repairing or replacing defective products or workmanship or damage resulting from the same. Seller warrants the products which it sells of other manufacturers to the extent of the warranties of their respective makers. Where engineering design or fabrication work is supplied, Buyer's acceptance of Seller's design or of delivery of work shall relieve Seller of all further obligation, other than as expressed in Seller's product warranty. THIS IS SELLER'S SOLE WARRANTY. SELLER MAKES NO OTHER WARRANTY OF ANY KIND, EXPRESSED OR IMPLIED. AND ALL IMPLIED WARRANTIES OF MERCHANTABILITY AND FITNESS FOR A PARTICULAR PURPOSE WHICH EXCEED SELLER'S AFORESTATED OBLIGATION ARE HEREBY DISCLAIMED BY SELLER AND EXCLUDED FROM THIS WARRANTY. Seller neither assumes, nor authorizes any person to assume for it, any other obligation in connection with the sale of its engineering designs or products. This warranty shall not apply to any products or parts of products which (a) have been repaired or altered outside of Seller's factory, in any manner; or (b) have been subjected to misuse, negligence or accidents; or (c) have been used in a manner contrary to Seller's instructions or recommendations. Seller shall not be responsible for design errors due to inaccurate or incomplete information supplied by Buyer or its representatives.

SELLER'S LIABILITY: Seller will not be liable for any loss, damage, cost of repairs, incidental or consequential damages of any kind, whether based upon warranty (except for the obligation accepted by Seller under "Warranty" above), contract or negligence, arising in connection with the design, manufacture, sale, use or repair of the products or of the engineering designs supplied to Buyer.



ENGINEERED FOR LIFE

Compact Automation Products

105 Commerce Way
Westminster, SC 29693
Phone: 864 647 9521
Fax: 864 647 9574
www.itt.com
www.compactautomation.com
www.turn-act.com

ITT Enidine Inc.

7 Centre Drive
Orchard Park, New York 14127
Phone: 716-662-1900
Fax: 716-667-1385
www.enidine.com

ITT Control Technologies GmbH

Werkstrasse 5
D-64732, Bad Koenig, Germany
Phone: +49 6063 9314 0
Fax: +49 6063 9314 44
www.compactautomation.eu

ITT High Precision Manufactured Products (Wuxi) Co. Ltd.

J Room 19th FL ZMI Plaza
No. 445 Kaixuan Road
Hangzhou, Zhejiang, China
Phone: 0086-571-86714399
Fax: 0086-571-86714055
www.itt.com
www.enidine.cn